

387



386



375

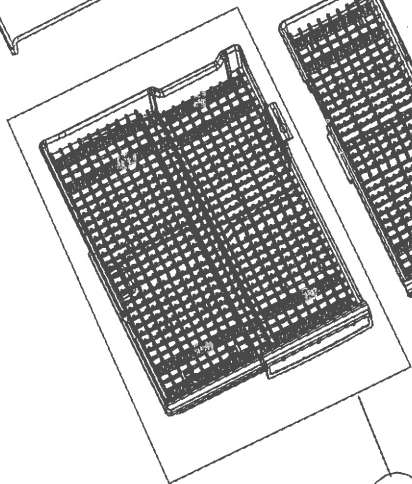
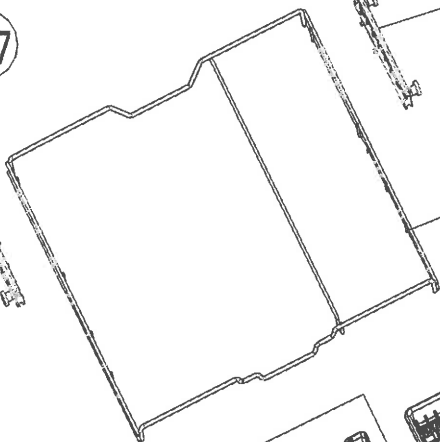

384

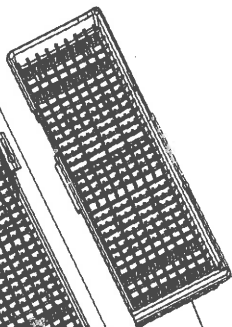

385

156



155



154

148

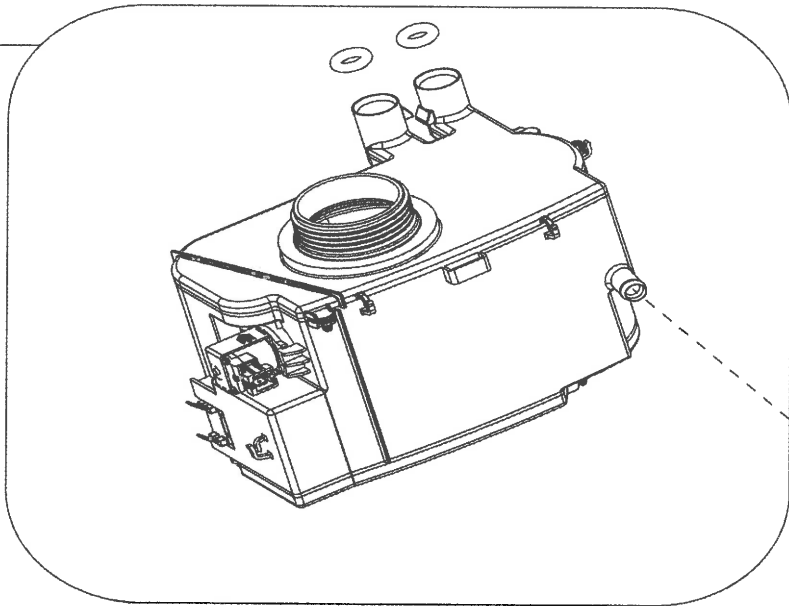

152

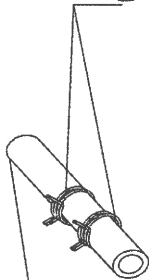

153



