

350

373

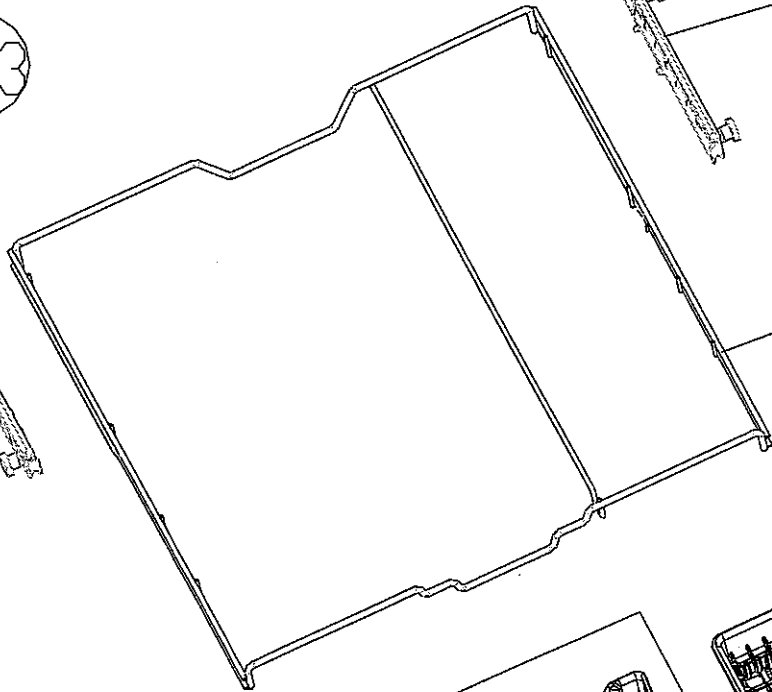

372



375

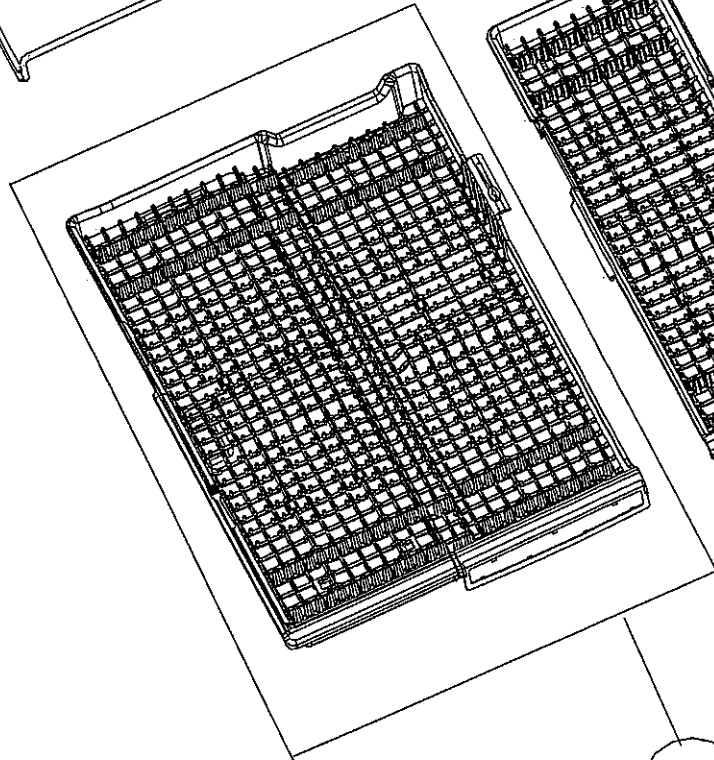

370

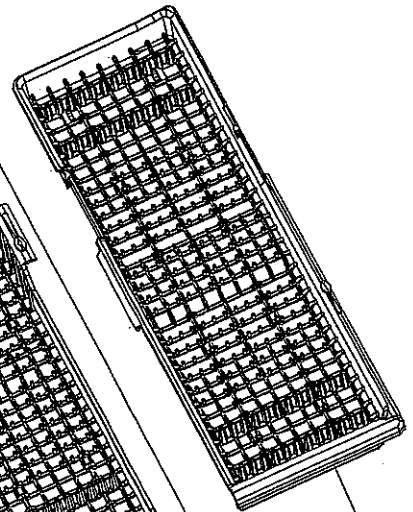

371



156

155

154

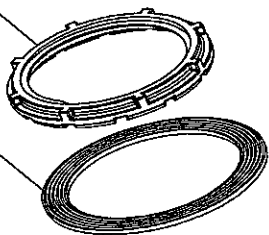

148

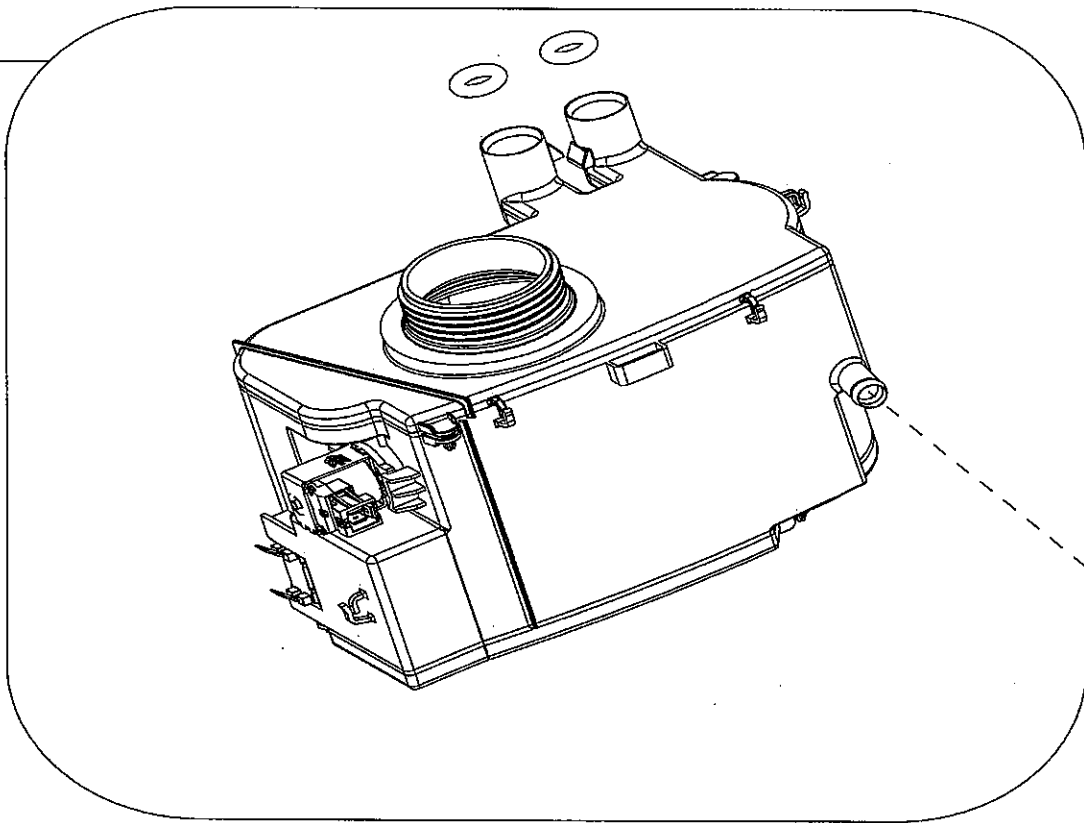

152

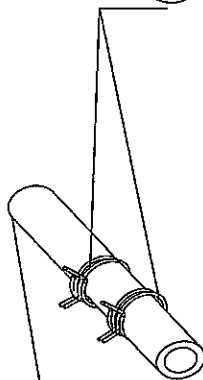

153

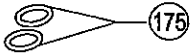
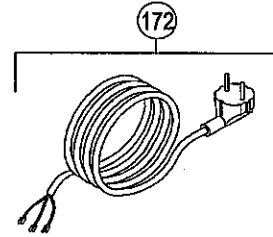
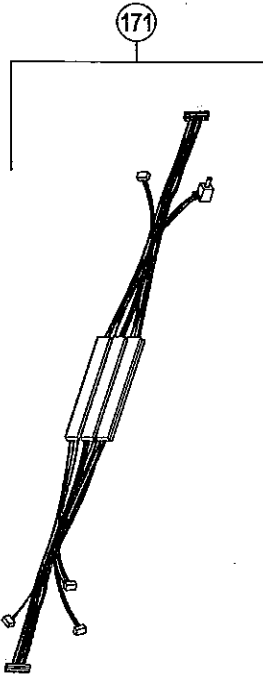
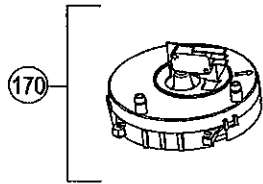
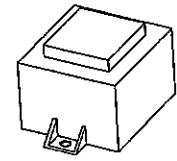
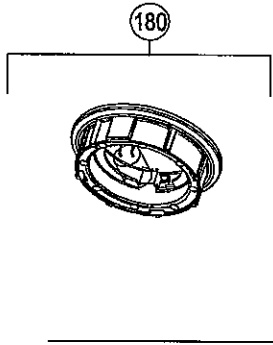

173

