

325

326

327

328

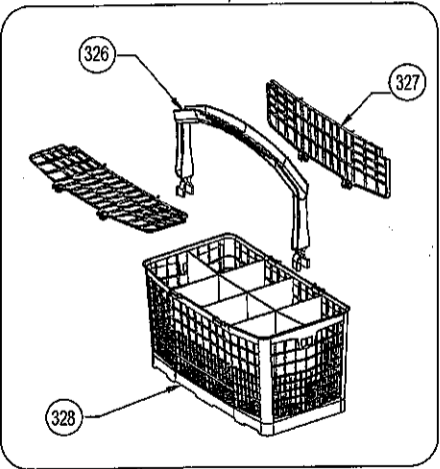

300

301

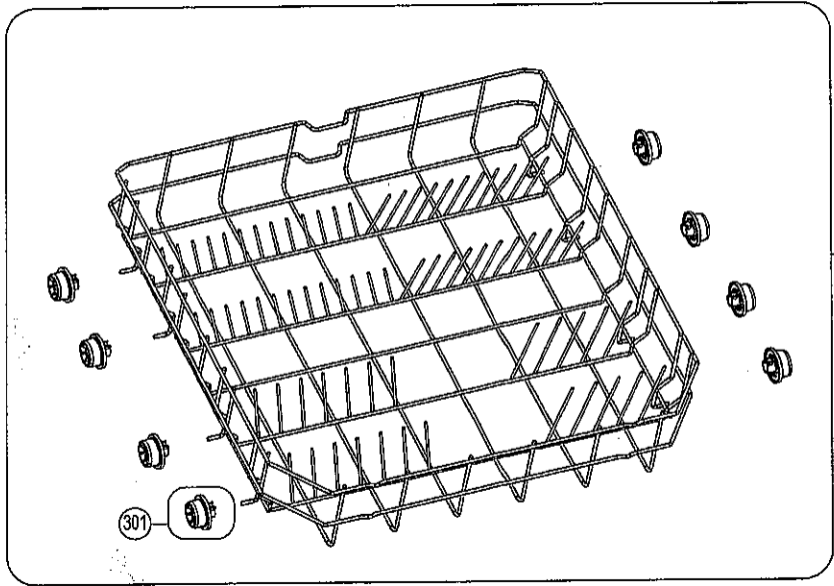

350

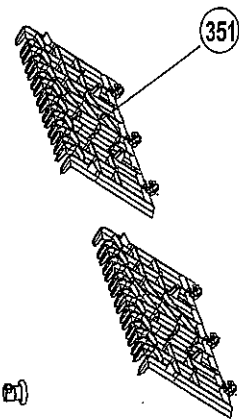
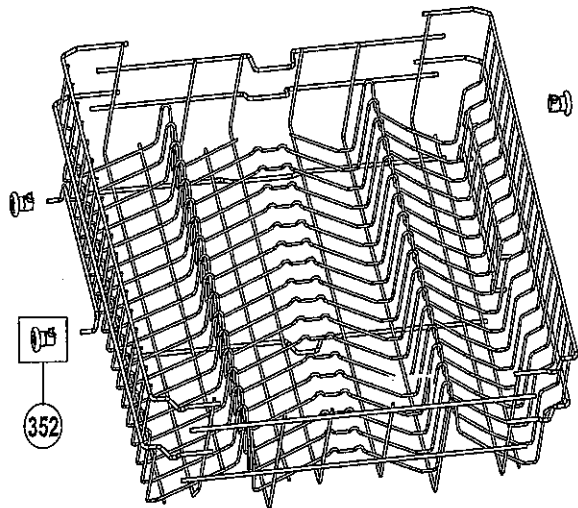

156

155

154

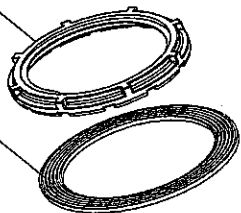

148

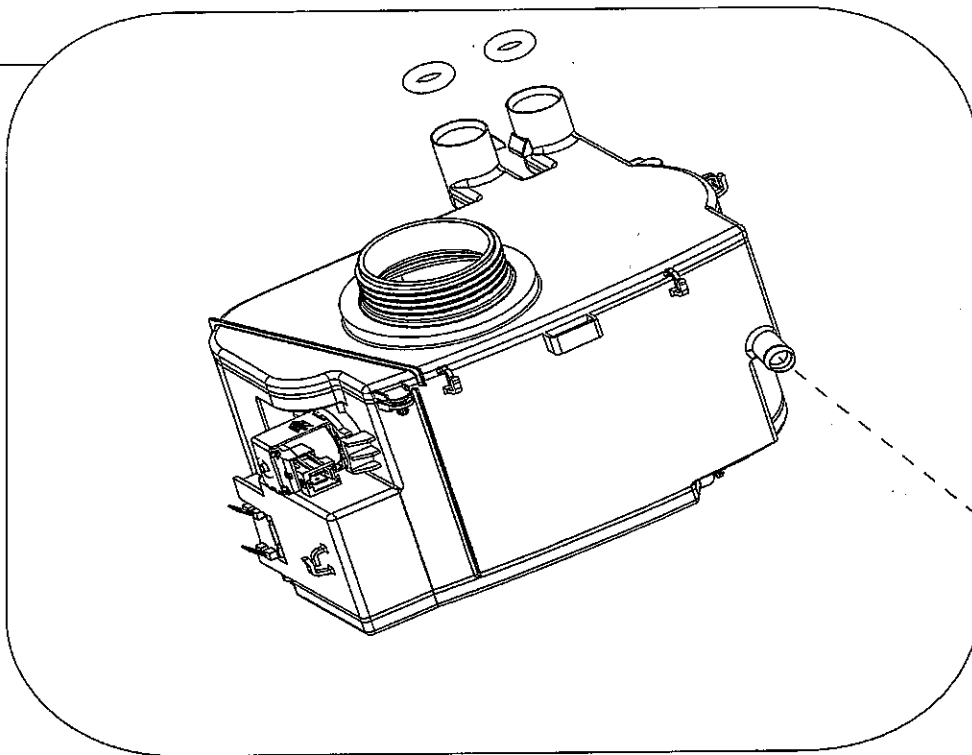

152

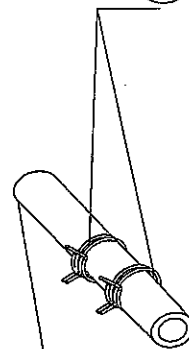

153

