

325

326

327

328

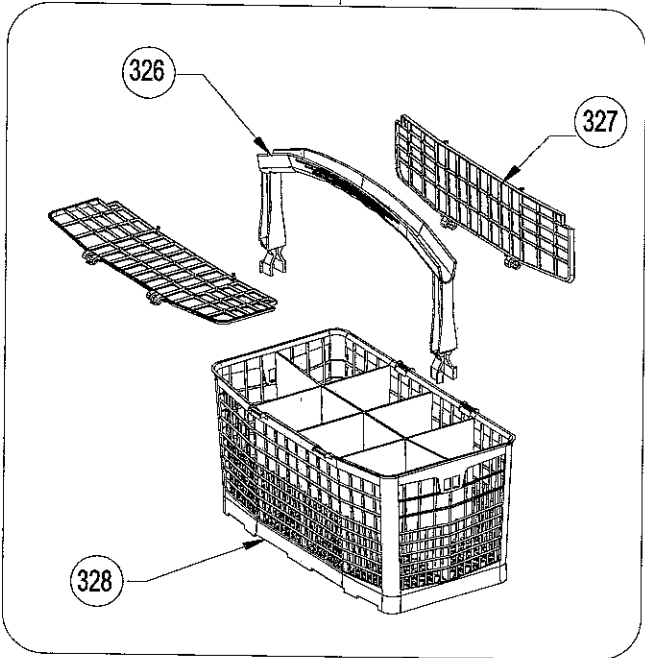

300

301

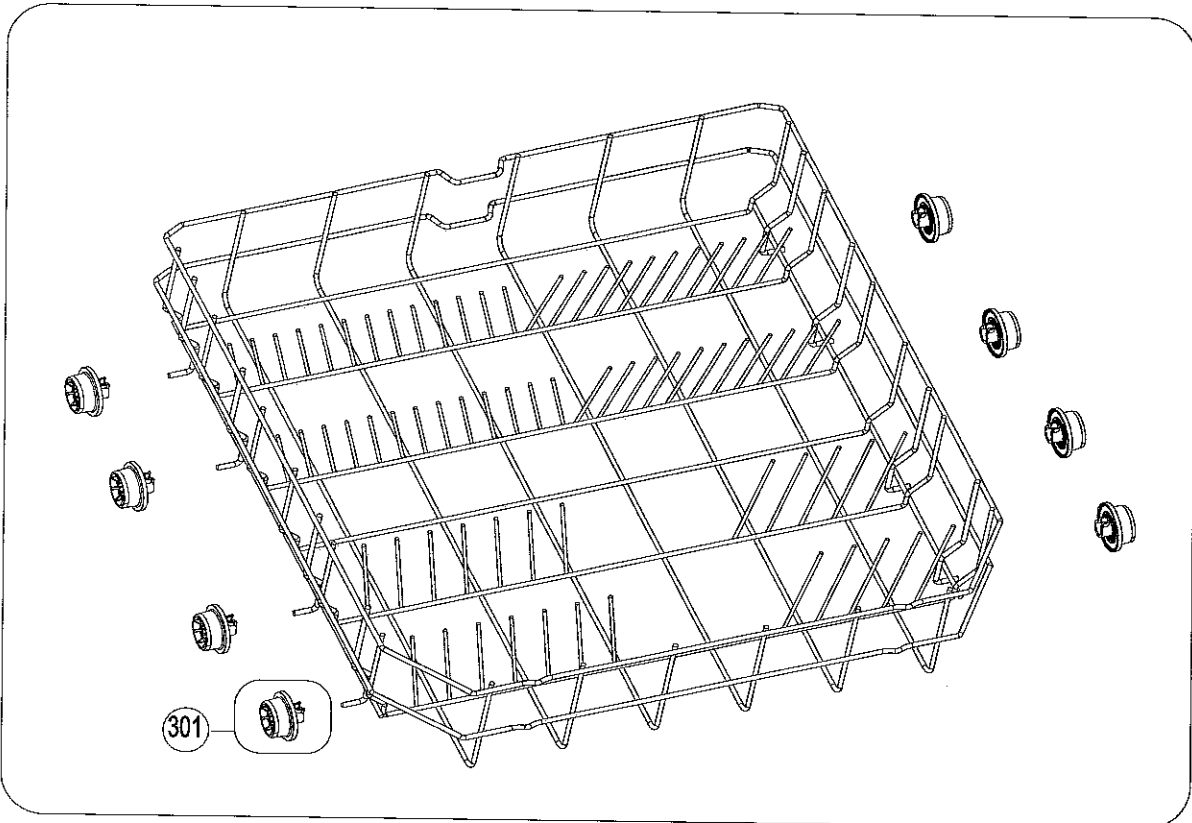

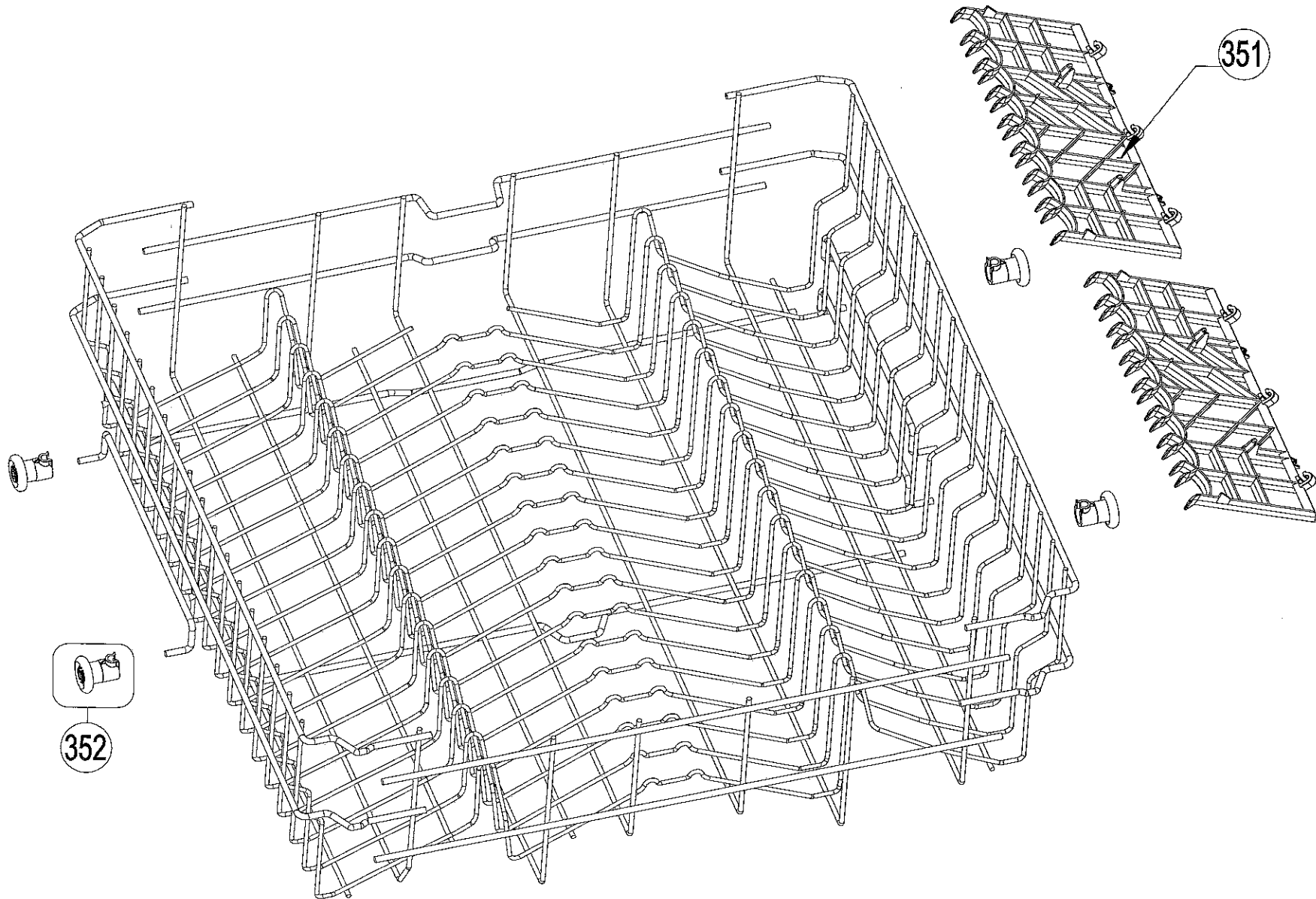

351

350

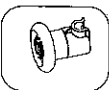

352



156

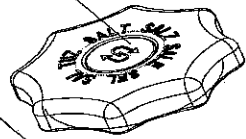

155

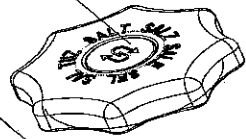

154

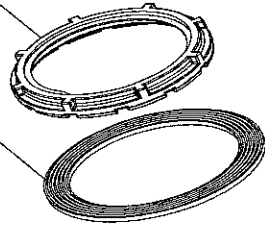

148

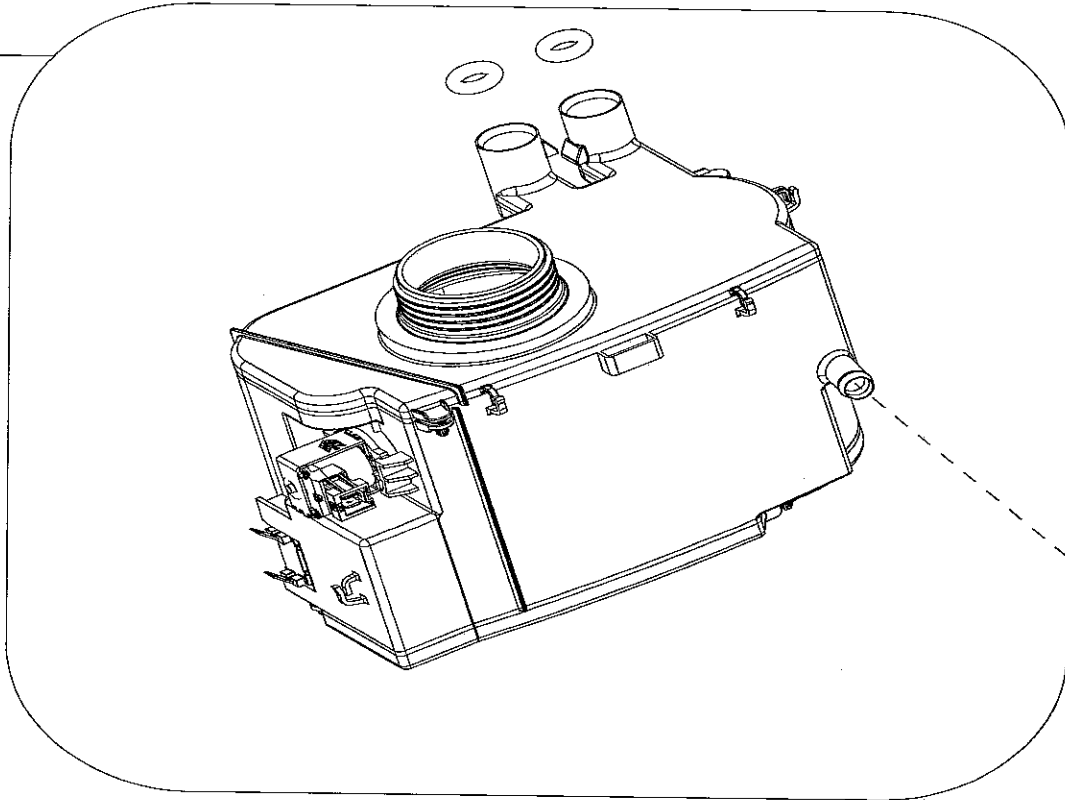

152

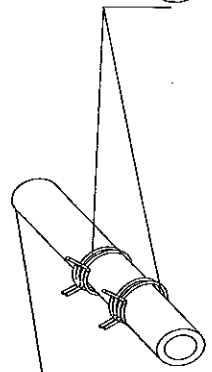

153

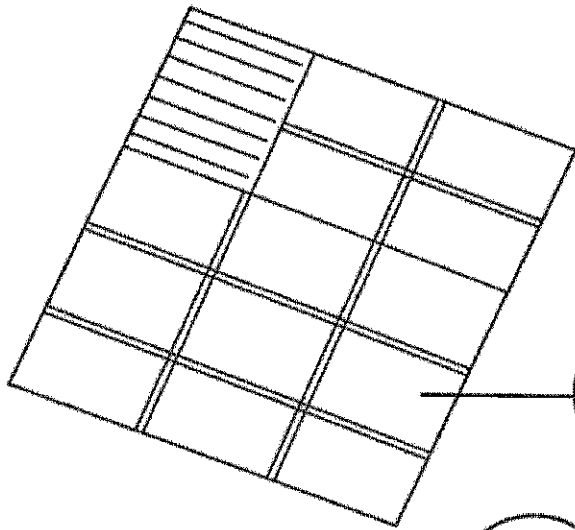

501

500



502

503



504



505

506



507



508



509



510



