

154

189

460



175

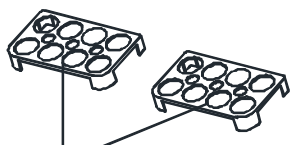

159

175



- 151
- 173
- 171

177



151

152

459

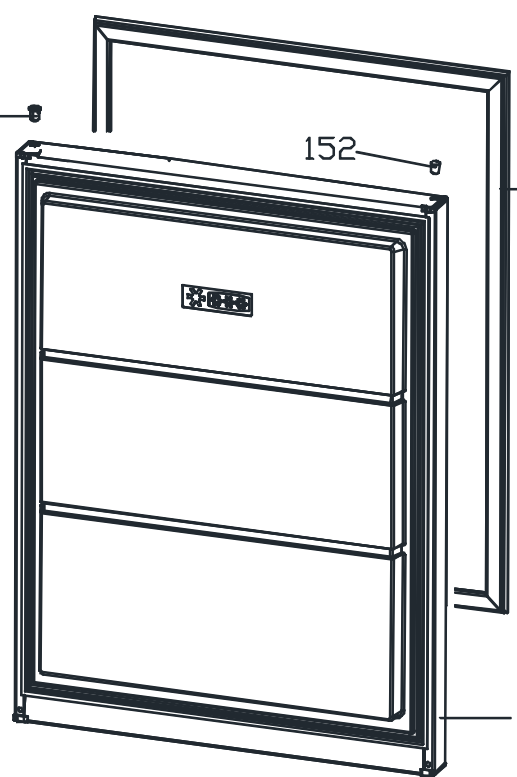

- 174B
- 174
- 187
- 510

606

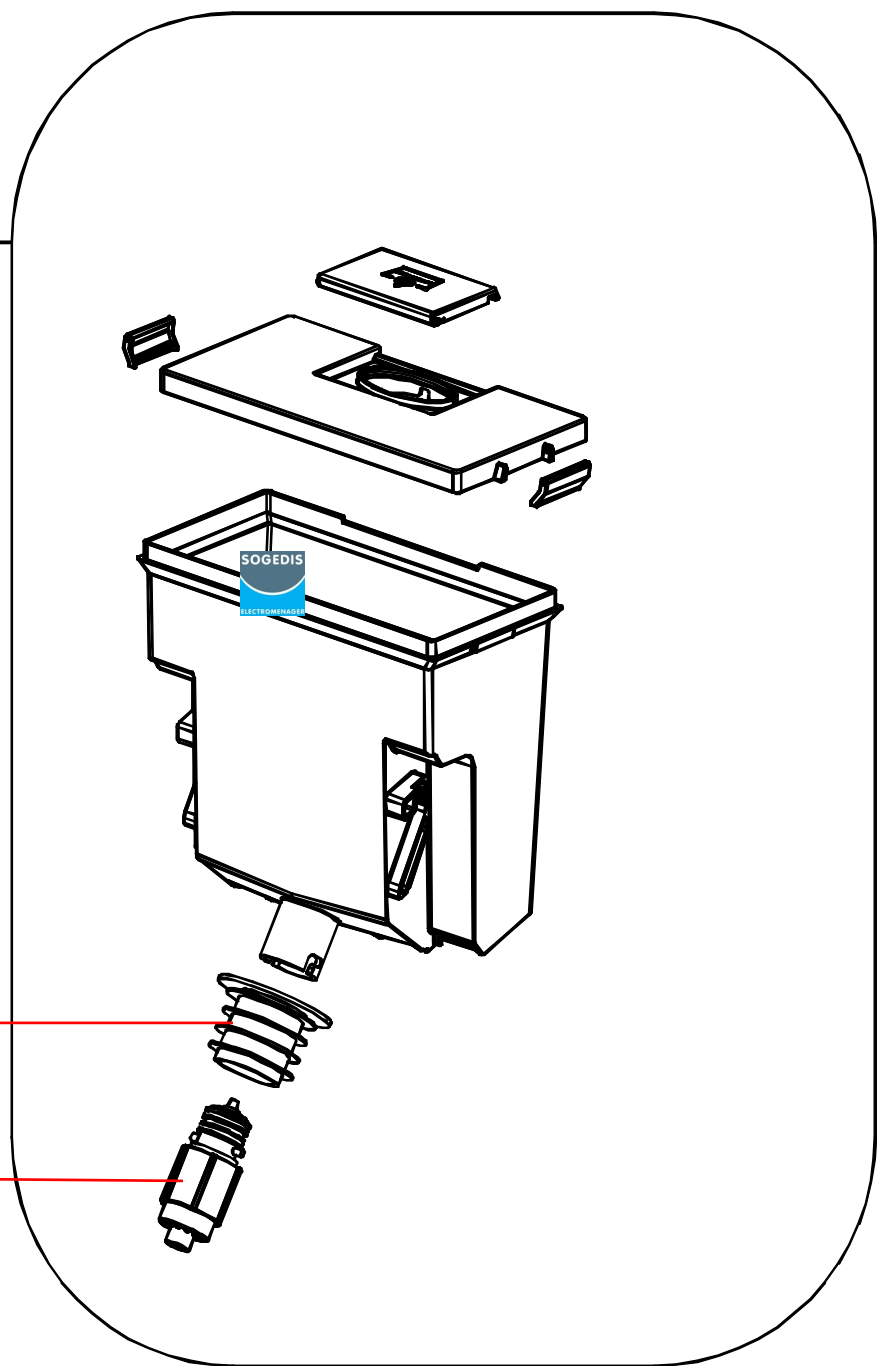

759

758

764

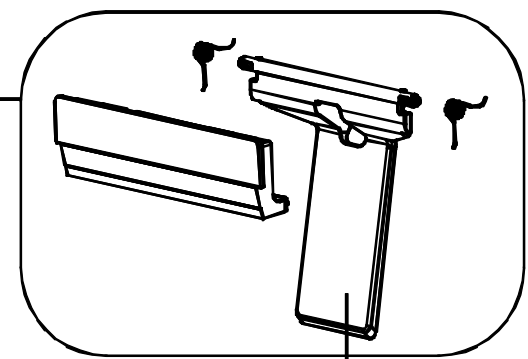

616

766



