

The thermostat automatically regulates the temperature inside the refrigerator and freezer compartments. Cooler temperatures can be obtained by rotating the knob to higher numbers, 1 to 5.

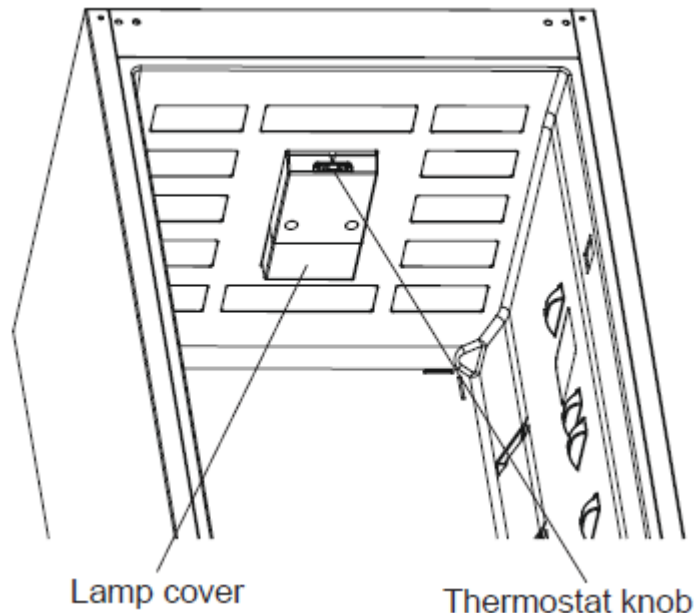

### Temperature Adjustment Warnings

- It is not recommended that you operate your fridge in environments colder than 10°C in terms of its efficiency.
- Temperature adjustments should be made according to the frequency of door openings, the quantity of food kept inside the fridge and the ambient temperature in the location of your fridge.
- In order to allow your fridge to reach the operating temperature after being connected to mains, do not open the doors frequently or place large quantities of food in the fridge. Please note that, depending on the ambient temperature, it may take 24 hours for your fridge to reach the operating temperature.
- A 5 minute delay function is applied to prevent damage to the compressor of your fridge when connecting or disconnecting to mains, or when an energy breakdown occurs. Your fridge will begin to operate normally after 5 minutes.
- Your appliance is designed to operate in the ambient temperature (T/SN = 10°C - 43°C) intervals stated in the standards, according to the climate class displayed on the information label. We do not recommend operating your appliance out of the stated temperature limits in terms of cooling effectiveness.

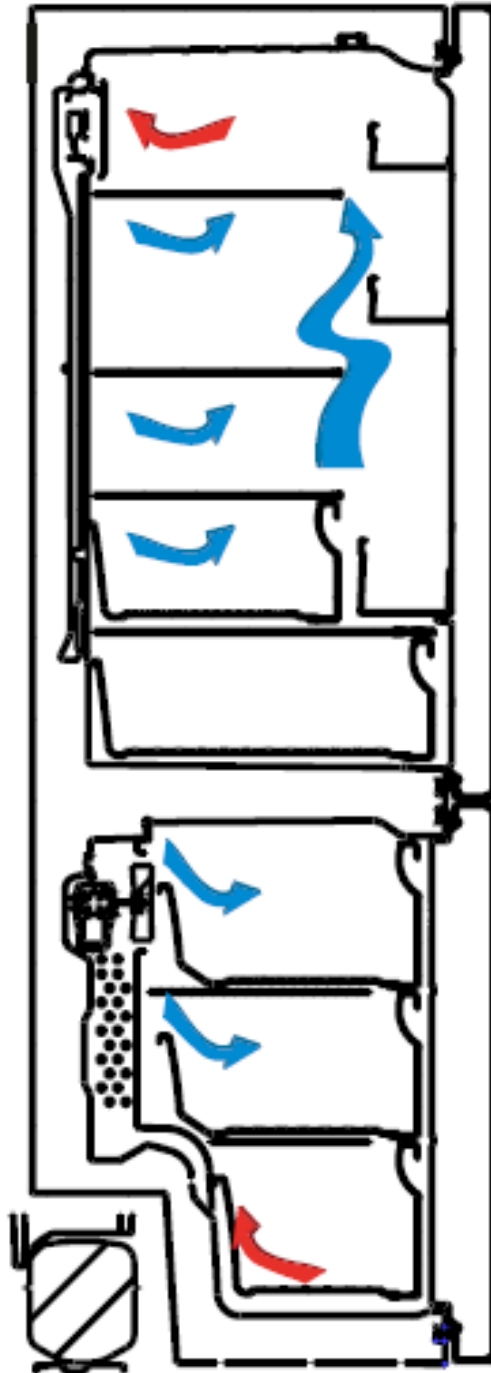

**Cutaway view: Air Flow Direction**

 **Blown : Cold Air**  
 **Returned: Hot Air**

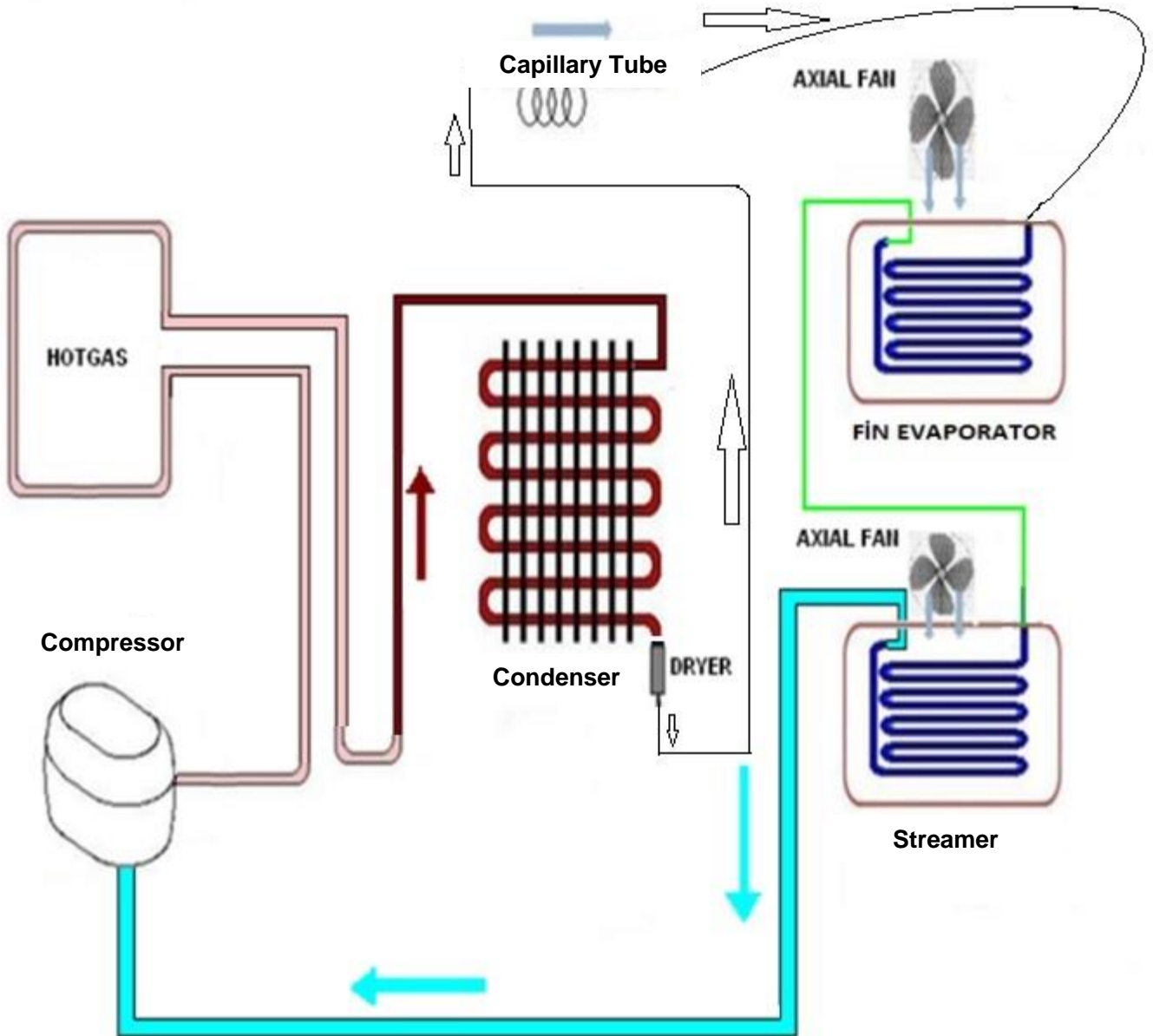

This model is double controlled product without any valve. When both cooler & freezer set by user :

Mainboard controls both the cooler sensor & freezer sensor. When cooler part reach requested value, if the freezer part haven't reach the requested level; compressor continues to run.

While freezer continue to cool down, with the help of the RDH (Ref. Defrost Heater ), cooler will stay at constant value. When the freezer reach the requested value both compressor & RDH will be stop.

<b>VESTEL</b> WHITE GOODS	<b>379 MECHANIC</b>	<b>CUSTOMER          SUPPORT</b>
	<b>Used Component</b>	

**Resistance Values According To The Temperature Sensor (°C/Ohm Rates)**

( For The Freezer Defrost and The Cooler Ambient Sensor)

45 °C/1kΩ	-1 °C/6.2kΩ
35 °C/1.5kΩ	-3 °C/6.8kΩ
30 °C/1.8kΩ	-5 °C/7.5kΩ
25 °C/2.2kΩ	-7 °C/8.2kΩ
19 °C/2.7kΩ	-12 °C/10kΩ
14 °C/3.3kΩ	-15 °C/12kΩ
10 °C/3.9kΩ	-20 °C/15kΩ
5.5 °C/4.7kΩ	-24 °C/18kΩ
1.5 °C/5.6kΩ	-31.5 °C/27kΩ
0 °C/6kΩ	-35.5 °C/33kΩ

**Sensor Resistance Values According To The Temperature (°C/Ohm Rates)**

(For The Cooler Defrost Sensor)

45 °C/2.15kΩ	-1 °C/17.1kΩ
35 °C/3.26kΩ	-3 °C/19kΩ
30 °C/4.02k4Ω	-5 °C/21.1kΩ
25 °C/5kΩ	-7 °C/23.5kΩ
19 °C/6.53kΩ	-12 °C/30.8kΩ
14 °C/8.23kΩ	-15 °C/36.5kΩ
10 °C/9.95kΩ	-20 °C/48.6kΩ
5.5 °C/12.3kΩ	-24 °C/61.5kΩ
1.5 °C/15kΩ	-31.5 °C/98kΩ
0 °C/16.3kΩ	-35.5 °C/12.6kΩ

<b>VESTEL</b> WHITE GOODS	<b>379 MECHANIC</b>	<b>CUSTOMER          SUPPORT</b>
	<b>Special Programs</b>	

### NTC Sensor

There are three types of sensors. They are cooler, freezer defrost, cooler defrost sensors. Cooler and freezer defrost sensors have the same features but their cable length is different. The resistance values of all sensors decrease when the temperature values of the sensors increase. For example, the resistance value that is 33 kΩ in the -35.5 °C goes down to 1kΩ in the 45 °C and therefore the ambient temperature should be considered while the sensor is being checked. If the ambient temperature is 25 °C, the measuring device shows about 2.2kΩ (if ntc sensor is steady).

### When the refrigerator works on first time;

If the cooler compartment defrost sensor and the freezer compartment defrost sensor are hotter than -5°C, the test system works automatically. These below components are tested automatically every 5 seconds.

- ❖The compressor and freezer fan motor starts and stops after 5 seconds.
- ❖The defrost resistance starts and stops after 5 seconds.
- ❖The cooler defrost resistance starts and stops after 5 seconds.
- ❖The DC Radial Fan starts and stops after 5 seconds.

After these steps, the system waits 5 minutes and then it will switch normal mod.

### Freezer Defrost Program

- According to the conditions of usage, the defrost might be activated after the min compressor running time; 8 hours or max total time; 55 hours. Below matters are also effected;
- Consisted ice amount,
- Door open-close,
- Sudden usage variance,
- Cooler sudden temperature rise,

### Cooler Defrost Program

The cooler defrost and the freezer defrost are operated parallel except those below. If the cooler defrost sensor does not feel 5°C three times during a particular period of time.

- Defrost will be activated after the refrigerator works max 9 hours. According to the conditions of usage, the defrost might be activated (due to mentioned those below) after the compressor works min 5 hours.
- Consisted ice amount,
- Door open-close,
- Sudden usage variance,
- Cooler sudden temperature rise,

<b>VESTEL</b> WHITE GOODS	<b>379 MECHANIC</b>	<b>CUSTOMER          SUPPORT</b>
	<b>Special Programs</b>	

### Freezer Defrosting Time

The Defrost is disabled when the defrost sensor temperature feels 8°C. If defrost time passes 37 minutes, defrost completing temperature will be rise to 15°C.

### Cooler Defrosting Time

The cooler defrost and the freezer defrost are operated parallel except those below. The cooler defrost will not work if the freezer defrost stops.

The defrost process stops when the defrost sensor temperature feels 7°C.

Compressor delay: First, the defrost process ends, the system waits 5 minutes, just after that the compressor is active.

### In Case of Power Cut

- All regulated parameters and functions are kept in memory when the power cut.
- When the electricity comes, if the defrost sensor temperature is lower than -5 °C the compressor works 5 minutes later. If it is higher than -5 °C.

### Other Features

Warnings : The door open warning is active 2 minutes later and it alarms.

Door Direction : It is possible to reverse the door.

Gasket : It is possible to change the gasket.

<b>VESTEL</b> WHITE GOODS	<b>379 MECHANIC</b>	<b>CUSTOMER SUPPORT</b>
	<b>Probable Faults</b>	

<b>Unsufficient cooling</b>	Is the appliance too close to wall or heat sources (stove, central heating, oven, cooker etc.)?	It should be placed min 50cm distance from heat sources and min 5 cm from electrical ovens.
	Is the ambient temperature high?	Raise the thermostat value.
	Check whether putting the hot foods in the refrigerator?	Put the foods after get cold.
	Is there any gas leakage in refrigerant system?	Check all welding points in the system.
<b>The foods in the cooler compartment are freezing.</b>	Were the foods placed close to cooling air outlet?	Please do not block air outlets
	Is the cooler thermostat value high ? Is there any hot foods close to the cooler sensor?	Decrease the cooler thermostat value and do not put hot things close to the sensor.
<b>Are there any sweating or icing?</b>	Were the liquid foods in the closed containers?	Put the liquid foods into the closed containers.
	Were the hot foods put into the refrigerator?	Put it into after getting cold.
	Was the refrigerator door opened?	Do not leave the refrigerator door open and do not often open or close.
<b>Abnormal Noise</b>	Is the appliance on the flat surface?	The floor should be straight and balance the refrigerator with the help of the adjustable feet.
	Is the compressor feet loose	Fix it.
	Is the condenser or fan stationary normal?	Fix it.
	Do the capillary tube or all other tubes touch any where?	Fix it.

Hold the top hinge cover and remove it toward that direction.

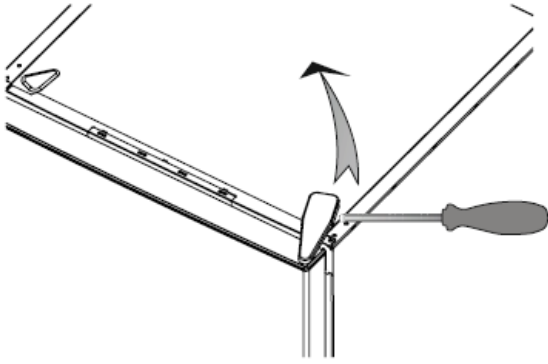

Unscrew the screws fixing the top hinge and remove it.

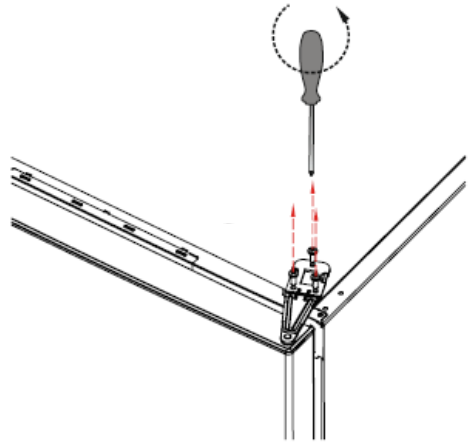

Displace the top door.

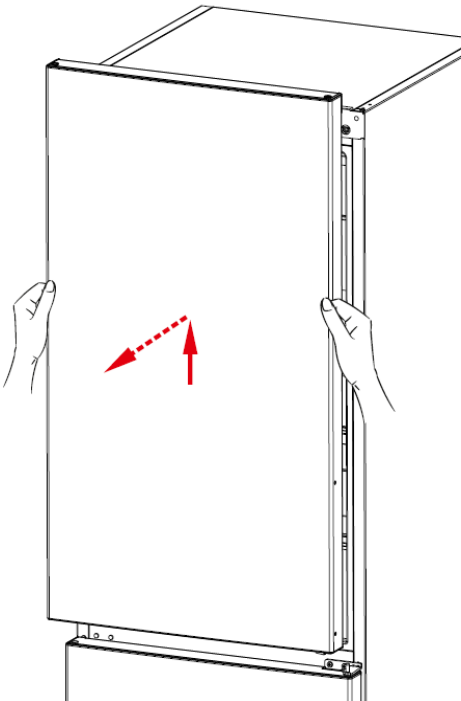

Remove the hinge cover cap and assembly right side.

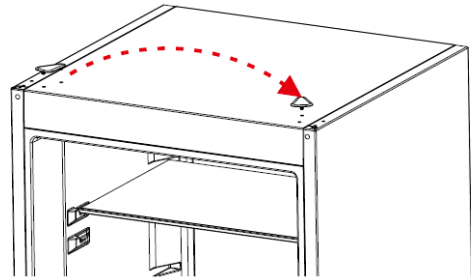

Unscrew the two screws fixing the middle hinge and remove it.

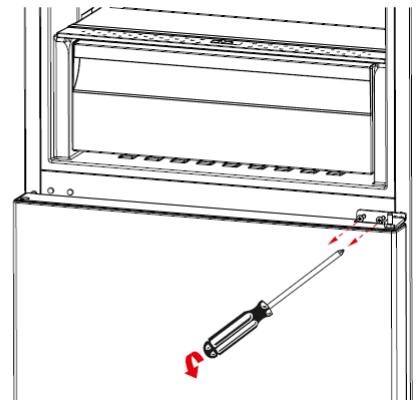



Displace the bottom door.

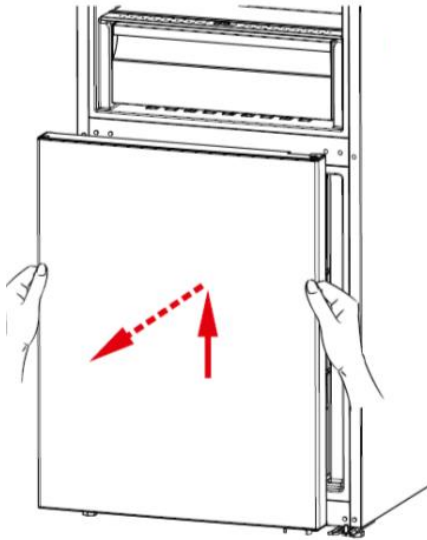

Unscrew the bottom hinge screws.  
Unscrew the adjustable foot.

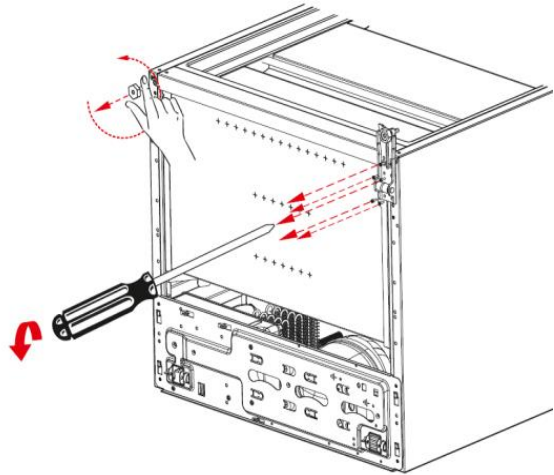

Unscrew the bottom hinge pin and  
screw it to other hole.

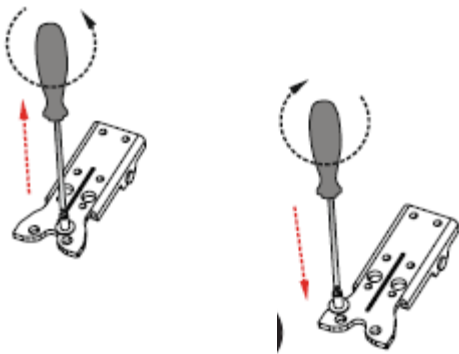

Screw the bottom hinge to the left bottom  
side of refrigerator. Screw the adjustable  
foot there.

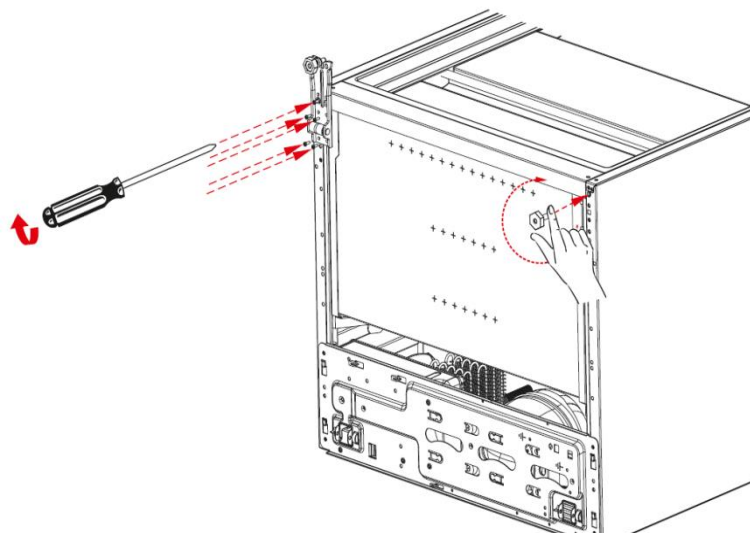

Replace the top bushing and the top bushing cap at the bottom door.

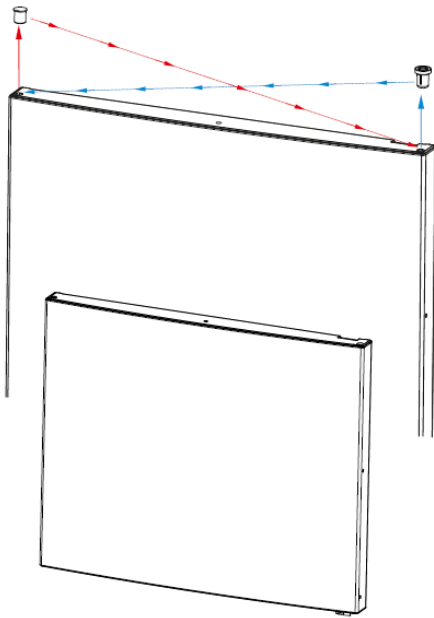

Unscrew the two screws fixing stopper and stopper support plate under the bottom door. After that screw the other side.

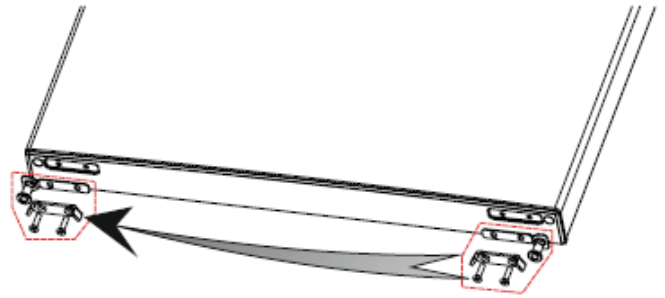

Remove the support plastic and then metal stopper placed under the upper door. Then re screw these parts to the other side symmetrically.

(remember the screw for the metal part must be screwed to the hole which is closer to the bushing). Do not use cordless screwdriver for these screws.

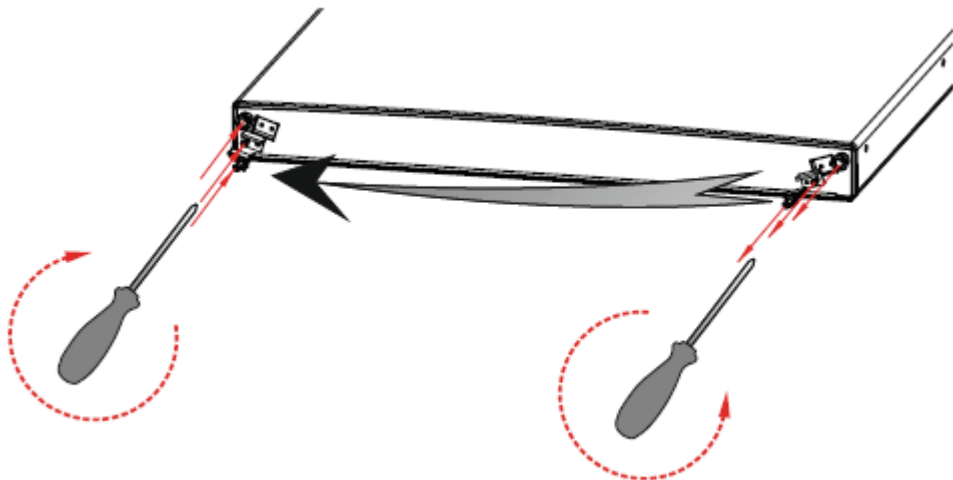

Remove the middle hinge cover and then screw the screw on the side panel and assemble to the right side panel

Place the bottom door and rotate the middle hinge by 180°. After that, screw to the right side on the middle sheet.

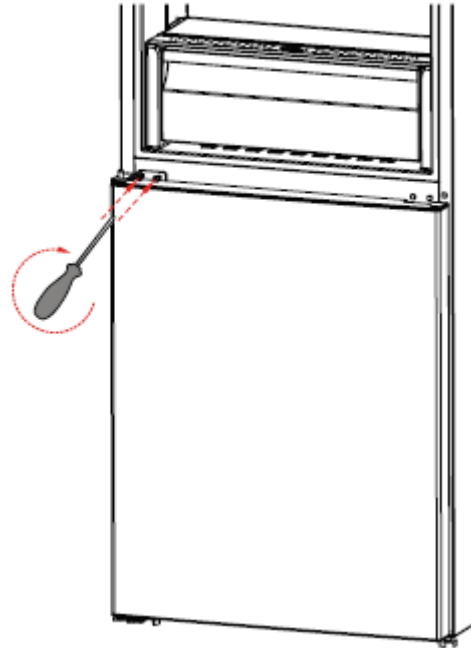
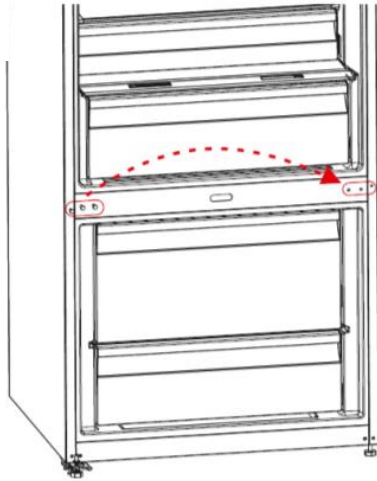

Place the top door to the middle hinge and then connect the display connector and screw the top hinge to the top panel. Place the top hinge cover.

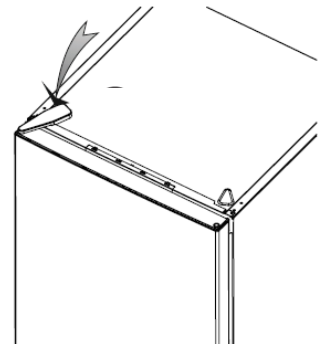
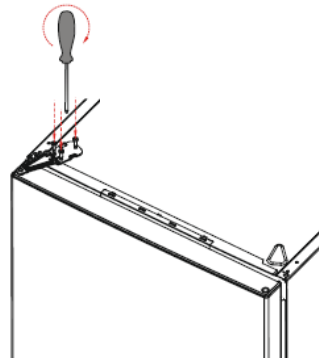
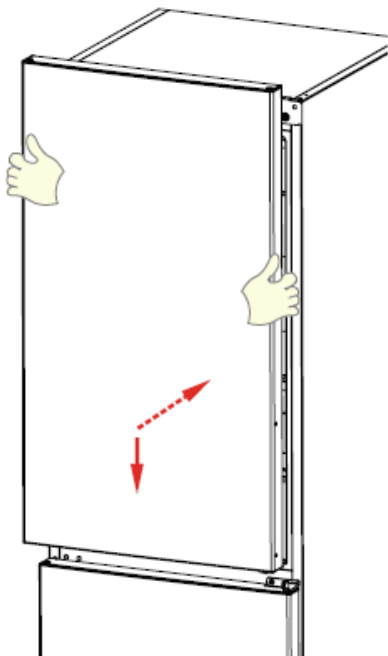

<b>VESTEL</b> WHITE GOODS	<b>379 MECHANIC</b>	<b>CUSTOMER          SUPPORT</b>
	Removing and Chancing The Mainboard	

**CAUTION: The plug must be pulled out before the mainboard group is removed.**

1. Unscrew the screws which are fixing the main board box. (Pic-1-2)



**Picture-1**



**Picture-2**

2. Pull the mainboard box slightly forward and disconnect all the connectors. (Pic-3)
3. Then place the front side of the box to the housing and then place box entirely and screw the screws with cross point screwdriver. (Pic-4)



**Picture-3**



**Picture-4**

<b>VESTEL</b> WHITE GOODS	<b>379 MECHANIC</b>	<b>CUSTOMER SUPPORT</b>
	<b>Removing- Assembling LEDs and LED's Covers</b>	

1. Press the snap fit cover with finger (Pic-1) and remove the box cover (Pic-2). After that operations, you can change the LED bulb.



**Picture-1**



**Picture-2**

2. For assembling, reverse the above operations..

1. Remove the cooler glass shelves and the chiller.



**Picture-1**

2. Remove the screw caps by using a flat screwdriver and screw the screws.

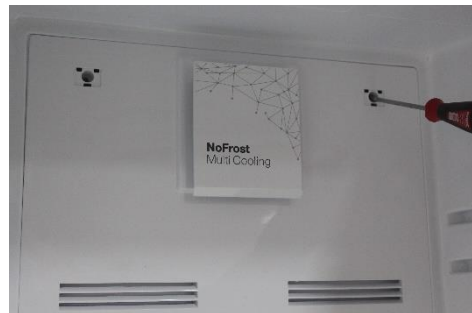

**Picture-2**

Flex the multi flow by holding the fan cover and remove it. Disconnect the connector after removing the multi flow.



**Picture-3**



**Picture-4**

<b>VESTEL</b> WHITE GOODS	<b>379 MECHANIC</b>	<b>CUSTOMER SUPPORT</b>
	<b>Removing The Cooler Multi Flow Fan Motor</b>	

1. Remove the fan cover by flexing the fan cover detail and then remove the fan motor by flexing the fan motor rubbers. (Pic-1/ Pic-2/Pic-3)



**Picture-1**



**Picture-2**



**Picture-3**

2. Place the rubbers to the fan motor. After that, first place the bottom two details of the fan motor and place the top two details by pressing-flexing it. (Pic-4/ Pic-5/Pic-6)

**Note : The fan motor cable outlet should be at the top-left corner of it.**

3. After the connector is connected, place it by flexing it and then reassemble the multi flow by screwing.



**Picture-4**



**Picture-5**



**Picture-6**

**1.** Remove the sensor cover with the help of a screwdriver and then disconnect the sensor connector. (Pic-1)

**2.** Place the bottom-front details of the cover to its housing and then place the top cover detail to the housing by flexing it with a screwdriver. (Pic-2)



**Picture-1**



**Picture-2**

***CAUTION: Pay attention not to damage to the sensor cover details!***



**Removing The Freezer Multi Flow Group**

1. Displace the glass shelves and baskets if there is. (Pic-1/Pic-2)
2. Unscrew the screw fixing the multiflow group. (Pic-3)
3. Removing the freezer bottom cover by flexing back side of it. (Pic-4)



**Picture-1**



**Picture-2**



**Picture-3**

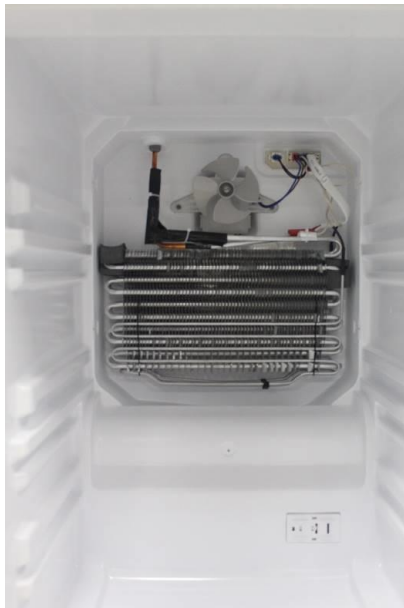

**Picture-4**

<b>VESTEL</b> WHITE GOODS	<b>379 MECHANIC</b>	<b>CUSTOMER SUPPORT</b>
	<b>Removing Fin Evaporator Group</b>	

1. Remove the fin evaporator resistance connectors from the sockets. (Pic-1) (blue connector)

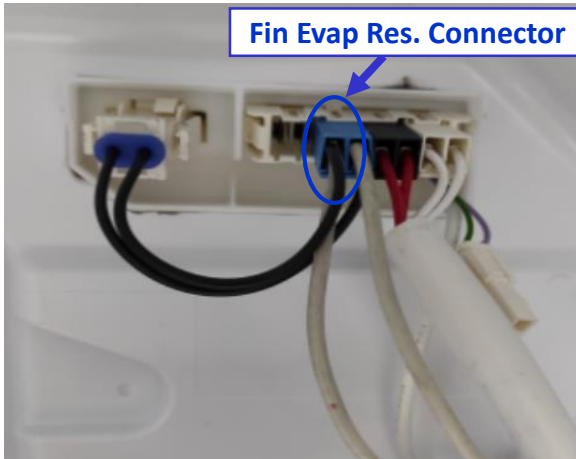

Picture-1

2. Displace the fin evaporator balanced by holding on both sides. (Pic-2)

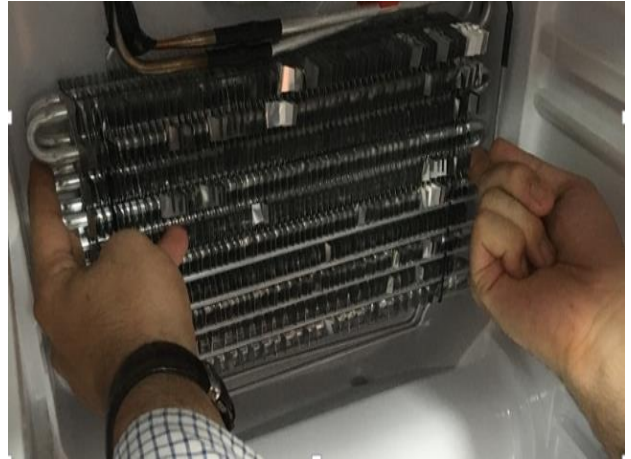

Picture-2

**CAUTION: The fin evaporator should not be pulled upward-downward. Otherwise, the fin evaporator fixing plastics might be broken.**

### Removing The Thermal Fuse

1. Remove the thermal fuse connector. (Pic-1) (black-white connector)

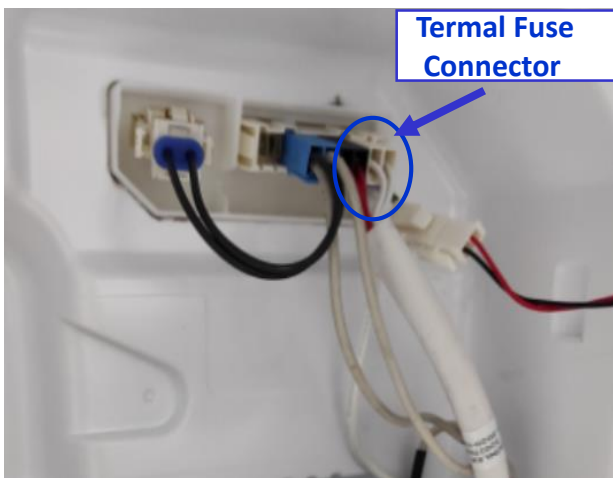

Picture-1

2. Thermal fuse has two details. These details hold on to the pipe. It could be removed easily. (Pic-2)



Picture-2

<b>VESTEL</b> WHITE GOODS	<b>379 MECHANIC</b>	<b>CUSTOMER SUPPORT</b>
	<b>Removing The Freezer Fan Motor</b>	

1. Unscrew the air duct plastic. (Pic-1)
2. When removing the air duct plastic, pay attention to the connection of the fan socket cable. (Pic-2)
3. Remove the fan motor connector. (Pic-3)



**Picture-1**



**Picture-2**



**Picture-3**

4. Unscrew the fan cover plastic on the fan motor. (Pic-4)
5. Unscrew the fan motor fixing screws and displace the fan motor. (Pic-5)

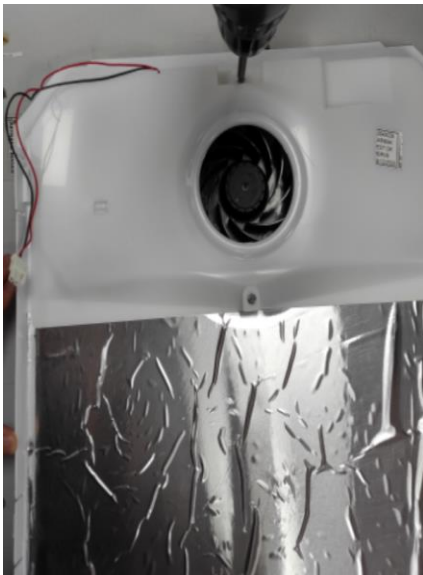

**Picture-4**



**Picture-5**

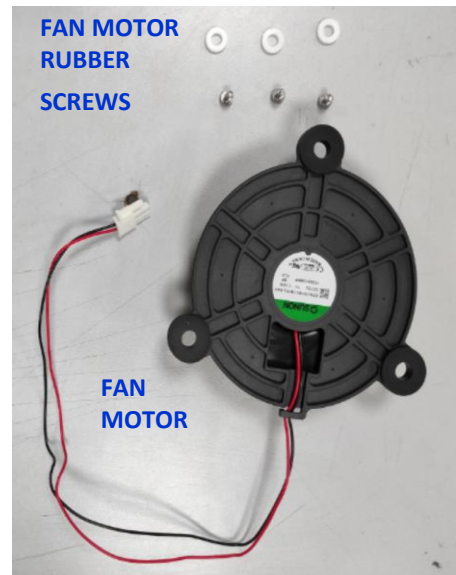

**Fan Motor Components**

Displace the defrost sensor from its location. Cut the end of the sensor cable by using pliers/side cutting pliers.

Connect the cut sensor cable ends to each other as separate clips.

Immobilize the sensor resistance's end its previous position by using cable bant.

In order to prevent oxidation on the metal end of clips. You can use paste which is founded in kit.

Excessive part of the cable should not be left scattered in order not entanglement on the fan motor. It should be fixed with a separate cable bant.

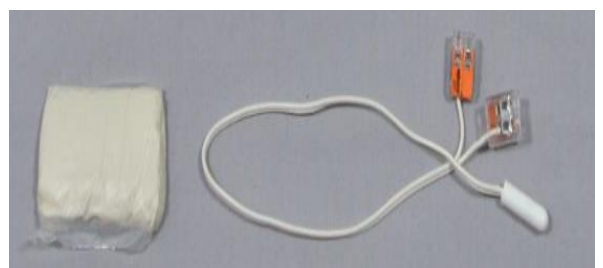
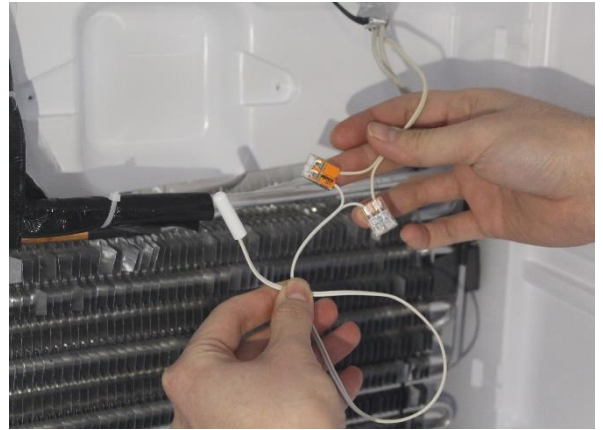
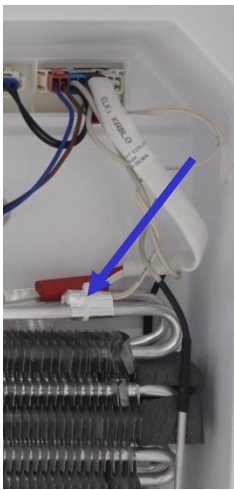
**32030727 - SENSOR SERVICE KIT**

1. Stick a tape to protect the body plastic. Flex it with the help of a tool like a slotted screwdriver. (Pic-1)



**Picture-1**

2. Also flex the top-side of the switch and then displace by pulling. (Pic-2)



**Picture-2**

3. Put the switch connector cable in the housing. First place the top-side of the switch and then push the bottom side.(Pic-3.1/Pic-3.2)



**Picture-3.1**



**Picture-3.2**

4. After the switch is placed, complete the assembly by pushing. (Pic-4)



**Picture-4.1**

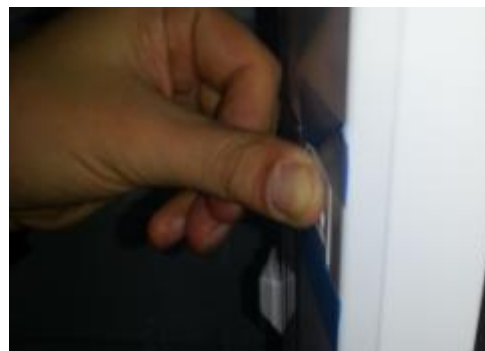

**Picture-4.2**

**CAUTION: The bottom-top details of the switch are different from each other to avoid assembling wrong!**

## Replacement of Door Gasket

Pull the gasket towards starting from top right corner  
Slowly pull the rest of the gasket.  
Completely remove the gasket from door.

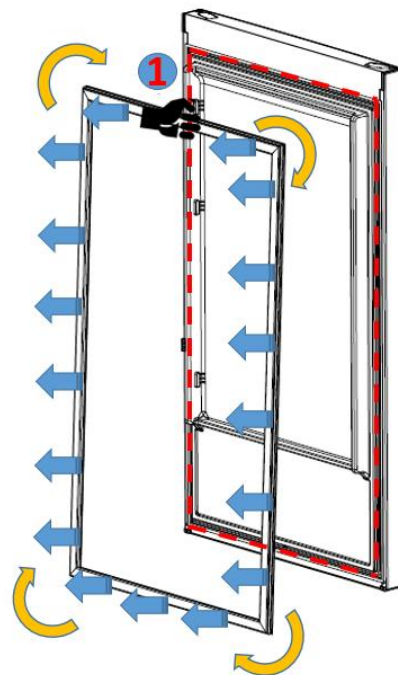

Check the replacement gasket form  
Starting with upper right corner, press on the gasket until it fits to its place..  
Place the other sides of the gasket with the help of your thumb

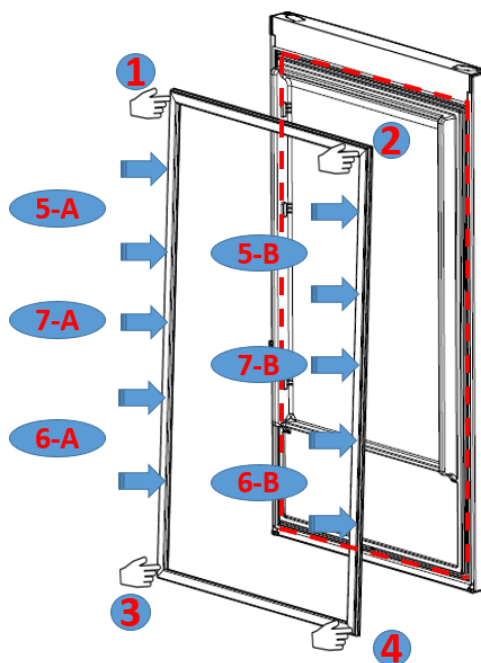

After the replacement check if there any non-fitting point on the gasket. Also check if there any opening at the gasket while the door is closed. If so that might cause condensation/icing or insufficient cooling/freezing. To prevent this soften the form of the gasket with the help of a hair dryer or hot water and make sure that all points are closing perfectly.

<b>VESTEL</b> WHITE GOODS	<b>379 MECHANIC</b>	<b>CUSTOMER SUPPORT</b>
	Barcode and Serial Number Explanation:	

Vestel refrigerator serial numbers are consist of 22 digits.

