

SERVICE MANUAL

MICROWAVE OVEN

**MODEL:
YC-PC322A**



In interests of user-safety the oven should be restored to its original condition and only parts identical to those specified should be used

TABLE OF CONTENTS

	Page
CAUTION, MICROWAVE RADIATION.....	2
SERVICING.....	3
PRODUCT DESCRIPTION	4
APPEARANCE VIEW.....	5
OPERATION SEQUENCE	7
FUNCTION OF IMPORTANT COMPONENTS	10
TEST PROCEDURE	11
CONTROL PANEL ASSEMBLY.....	17
COMPONENT REPLACEMENT AND ADJUSTMENT PROCEDURE.....	20
MICROWAVE MEASUREMENT	27
SCHEMATIC	28
EXPLODED DIAGRAM OF OVEN PARTS	29
PART LIST	30

SERVICE MANUAL

MICROWAVE OVEN

GENERAL IMPORTANT INFORMATION

This Manual has been prepared to provide Service engineers with Operation and Service Information.

It is recommended that service engineers carefully study the entire text of this manual, so they will be qualified to render satisfactory customer service.

CAUTION
MICROWAVE RADIATION
DO NOT BECOME EXPOSED TO RADIATION FROM THE MICROWAVE GENERATOR OR OTHER PARTS THAT CONDUCT MICROWAVE ENERGY.

WARNING

- Note: The parts marked "*" are used in voltage more than 250V. (Parts List)
- Anm: Delar märket med "*" har en spänning överstigande 250V.
- Huom: Huolto-ohjeeseen merkitty "tähdellä" osat joissa jännite on yli 250 V.
- Bemerk: Deler som er merket "asterisk" er utsatt for spenninger over 250V til jord.
- Bemærk: "Dele mærket med stjerne benyttes med højere spænding end 250 volt.

WARNING

Never operate the oven until the following points are ensured.

- (A) The door is tightly closed.
- (B) The door brackets and hinges are not defective.
- (C) The door packing is not damaged.
- (D) The door is not deformed or warped.
- (E) There is not any other visible damage with the oven.

Servicing and repair work must be carried out only by trained service engineers.

All the parts marked "*" on parts list are used at voltage more than 250V.

Removal of the outer wrap gives access to potential above 250V.

All the parts marked "Δ" on the parts list may cause undue microwave exposure, by themselves, or when they are damaged, loosened or removed.

SERVICING

WARNING TO SERVICE PERSONNEL

Microwave ovens contain circuitry capable of producing very high voltage and current, contact with following parts will result in electrocution.

High voltage capacitor, High voltage transformer, Magnetron, High voltage rectifier assembly, High voltage harness.

REMEMBER TO CHECK 3D

- 1) Disconnect the supply.
- 2) Door opened, and wedged open.
- 3) Discharge high voltage capacitor.

WARNING: AGAINST THE CHARGE OF THE HIGH-VOLTAGE CAPACITOR

The high-voltage capacitor remains charged about 60 seconds after the oven has been switched off. Wait for 60 seconds and then short-circuit the connection of the high-voltage capacitor (that is, of the connecting lead of the high-voltage rectifier) against the chassis with the use of an insulated screwdriver.

It is recommend that wherever possible fault-finding is carried out with the supply disconnected. It may in, some cases, be necessary to connect the supply after the outer case has been removed, in this event carry out 3D checks and then disconnect the leads to the primary of the High voltage transformer. Ensure that these leads remain isolated from other components and the oven chassis. (Use insulation tape if necessary.) When the testing is completed carry out 3D checks and reconnect the leads to the primary of the High voltage transformer.

REMEMBER TO CHECK 4R

- 1) Reconnect all leads removed from components during testing.
- 2) Replace the outer case (cabinet).
- 3) Reconnect the supply.
- 4) Run the oven. Check all functions.

Microwave ovens should not be run empty. To test for the presence of microwave energy within a cavity, place a cup of cold water on the oven turntable, close the door and set the power to HIGH and set the microwave timer for two (2) minutes. When the two minutes has elapsed (timer at zero) carefully check that the water is now hot. If the water remains cold carry out 3D checks and re-examine the connections to the component being tested.

When all service work is completed, and the oven is fully assembled, the microwave power output should be checked and a microwave leakage test should be carried out.

When troubleshooting the microwave oven, it is helpful to follow the Sequence of Operation in performing the checks. Many of the possible causes of trouble will require that a specific test be performed. These tests are given a procedure letter which will be found in the "Test Procedure" section.

IMPORTANT: If the oven becomes inoperative because of a blown fuse F1 in the monitored latch switch - monitor switch - circuit, check the monitored latch switch and monitor switch and before replacing the fuse F1.

**PRODUCT DESCRIPTION -PC322A
SPECIFICATION**

ITEM	DESCRIPTION
Power Requirements	230-240 Volts / 50 Hertz / Single phase, 3 wire earthed
Power Consumption	Microwave cooking 1.0kW
	Grill cooking 1.3kW
	Convection cooking 2.3kW
Power Output	1000 W nominal of RF microwave energy (measured by method of IEC 60705) Operating frequency 2450 MHz
Grill heating element Power Output	1300 W
Convection heating element Power Output	2300W
Case Dimensions	Width 539 mm Height 300 mm Depth 545 mm
Cooking Cavity Dimensions	Width 362 mm Height 223 mm Depth 378 mm
Turntable Diameter	315mm/ Grill rack 255*80mm/Baking Tray 317.4*47.5
Control Complement	<p>Touch Control System</p> <p>Microwave Power for Variable Cooking</p> <p>Repetition Rate;</p> <p>100% (HIGH)..... Full power throughout the cooking time</p> <p>90% (HIGH) approx. 90% of FULL Power</p> <p>80% (MEDIUM HIGH)..... approx. 80% of FULL Power</p> <p>70% (MEDIUM HIGH)..... approx. 70% of FULL Power</p> <p>60% (MEDIUM)..... approx. 60% of FULL Power</p> <p>50% (MEDIUM) approx. 50% of FULL Power</p> <p>40% (MEDIUM LOW) approx. 40% of FULL Power</p> <p>30% (MEDIUM LOW) approx. 30% of FULL Power</p> <p>20% (LOW) approx. 20% of FULL Power</p> <p>10% (LOW) approx. 10% of FULL Power</p> <p>GENERAL INFORMATION</p> <ol style="list-style-type: none"> 1. DIGITAL DISPLAY 2. 10 SECONDS, 1 MINUTE, 10 MINUTES 3. AUTO MENU keys 4. START/QUICKSTART 5. MICROWAVE POWER 6. GRILL 7. MICROWAVE+GRILL 8. CONVECTION TEMPERATURE 9. MICROWAVE+CONVECTION 10. UP 11. DOWN 12. STOP/ECO 13. CHILD LOCK 14. TIME/SET CLOCK
Net Weight	Approx. 20.75kg

WARNING

THIS APPLIANCE MUST BE EARTHED

IMPORTANT

THE WIRES IN THIS MAINS LEAD ARE COLOURED IN ACCORDANCE WITH THE FOLLOWING CODE:

GREEN-AND-YELLOW	: EARTH
BLUE	: NEUTRAL
BROWN	: LIVE

APPEARANCE VIEW-PC322A

OVEN AND ACCESSORIES

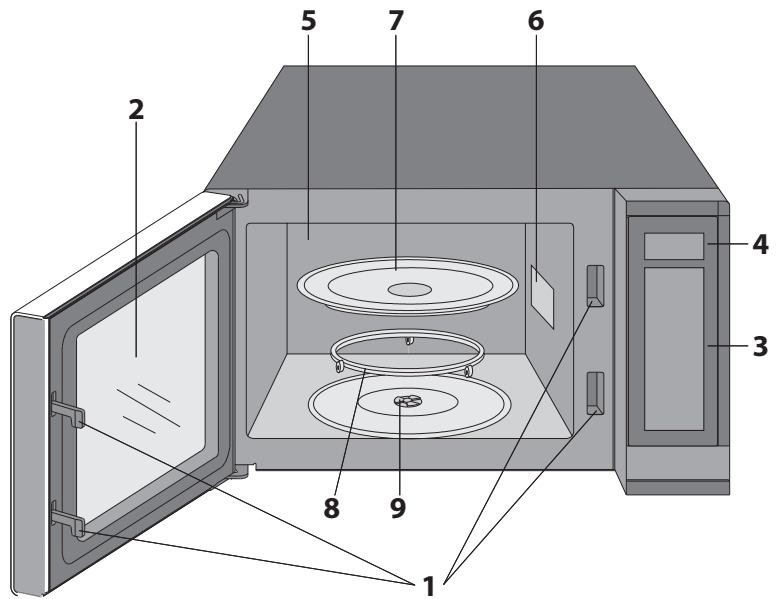

1. Door safety lock system
2. Oven window
3. Control Panel
4. Display
5. Oven cavity
6. Waveguide Cover (Do Not remove)
7. Glass Tray
8. Roller Ring
9. Turntable Coupling
10. Baking Tray
11. Grill Rack
12. Ventilation openings
13. Outer cabinet
14. Power supply cord

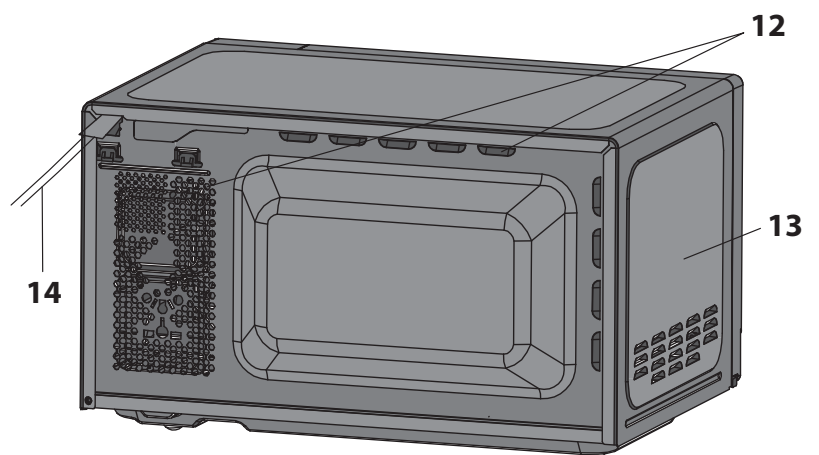
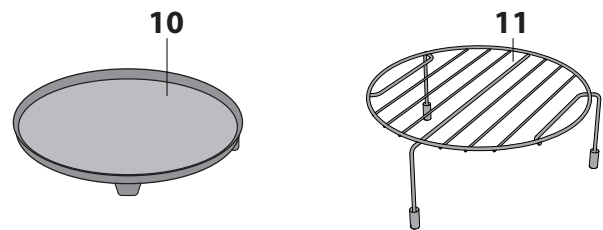

- The Grill Rack and Baking Tray are designed for use with grill and convection ovens only. DO NOT use any metal accessories when using the microwave function.
- For use of the Grill Rack refer to the GRILL sections of this User Manual.



CONTROL PANEL -PC322A

1. **DIGITAL DISPLAY** – Cooking time, power, indicators and clock time are displayed.
2. **10 SECONDS, 1 MINUTE, 10 MINUTES** – Use these buttons to set the cooking time and clock.
3. **AUTO MENU keys** – Press to select auto cooking menu.
4. **START/QUICK START**
5. **MICROWAVE POWER** – Press to select microwave power level.
6. **GRILL** – Press to set grill cooking program.
7. **MICROWAVE+GRILL** – Press to set microwave and grill combination cooking program.
8. **CONVECTION TEMPERATURE** – Press to select convection temperature.
9. **MICROWAVE+CONVECTION** – Press to select convection ombination cooking.
10. **UP**  – Press to set food weight or servings.
11. **DOWN**  – Press to set food weight or servings.
12. **STOP/ECO** – Press once to temporarily stop cooking, or twice to cancel cooking altogether. Use to set power saving mode.
13. **CHILD LOCK**
14. **TIME/SET CLOCK** – Use to set clock time. Use to set timer function.

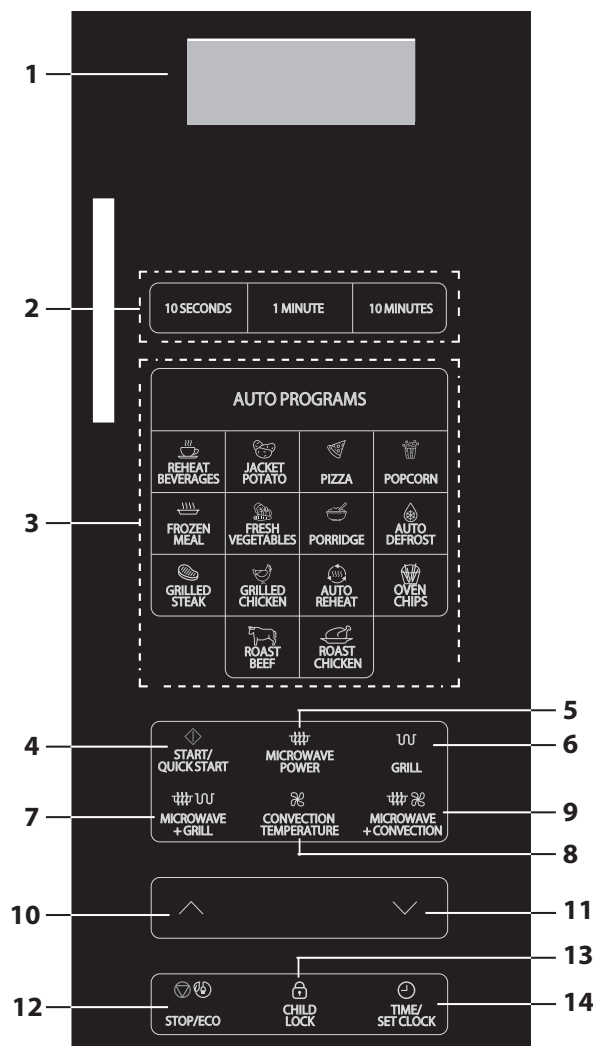

PRODUCT DESCRIPTION -PC284A
SPECIFICATION

ITEM	DESCRIPTION
Power Requirements	230-240 Volts / 50 Hertz / Single phase, 3 wire earthed
Power Consumption	Microwave cooking 0.9kW
	Grill cooking 1.25kW
	Convection cooking 2.2kW
Power Output	900 W nominal of RF microwave energy (measured by method of IEC 60705) Operating frequency 2450 MHz
Grill heating element Power Output	1250 W
Convection heating element Power Output	2200W
Case Dimensions	Width 539 mm Height 300 mm Depth 485 mm
Cooking Cavity Dimensions	Width 354 mm Height 220 mm Depth 358 mm
Turntable Diameter	315mm/ Grill rack 255*80mm/Baking Tray 317.4*47.5
Control Complement	<p>Touch Control System</p> <p>Microwave Power for Variable Cooking</p> <p>Repetition Rate;</p> <p>100% (HIGH)..... Full power throughout the cooking time</p> <p>90% (HIGH) approx. 90% of FULL Power</p> <p>80% (MEDIUM HIGH)..... approx. 80% of FULL Power</p> <p>70% (MEDIUM HIGH)..... approx. 70% of FULL Power</p> <p>60% (MEDIUM)..... approx. 60% of FULL Power</p> <p>50% (MEDIUM) approx. 50% of FULL Power</p> <p>40% (MEDIUM LOW) approx. 40% of FULL Power</p> <p>30% (MEDIUM LOW) approx. 30% of FULL Power</p> <p>20% (LOW) approx. 20% of FULL Power</p> <p>10% (LOW) approx. 10% of FULL Power</p> <p>GENERAL INFORMATION</p> <ol style="list-style-type: none"> 1. DIGITAL DISPLAY 2. 10 SECONDS, 1 MINUTE, 10 MINUTES 3. AUTO MENU keys 4. START/QUICK START 5. MICROWAVE POWER 6. GRILL 7. MICROWAVE+GRILL 8. CONVECTION TEMPERATURE 9. MICROWAVE+CONVECTION 10. UP 11. DOWN 12. STOP/ECO 13. CHILD LOCK 14. TIME/SET CLOCK
Net Weight	Approx. 18.96kg

APPEARANCE VIEW-PC284A

OVEN AND ACCESSORIES

1. Door safety lock system
2. Oven window
3. Control Panel
4. Display
5. Oven cavity
6. Waveguide Cover (Do Not remove)
7. Glass Tray
8. Roller Ring
9. Turntable Coupling
10. Baking Tray
11. Grill Rack
12. Ventilation openings
13. Outer cabinet
14. Power supply cord

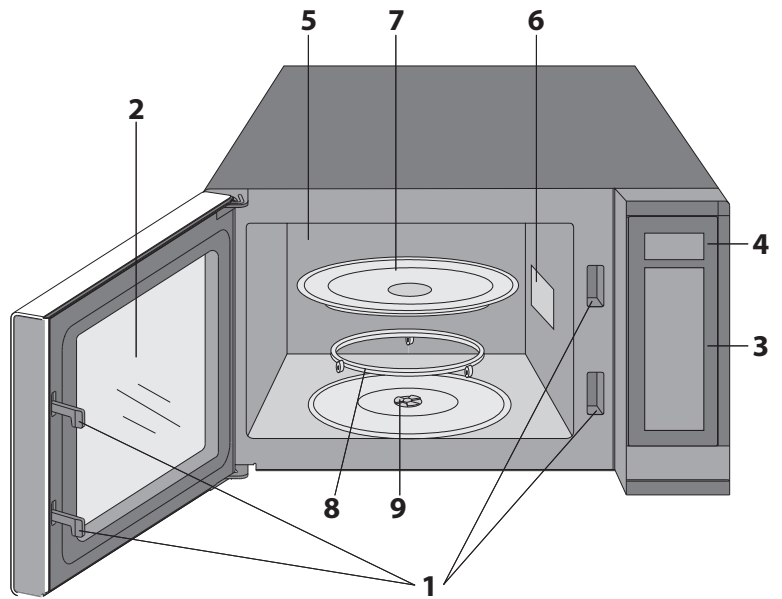

- The Grill Rack and Baking Tray are designed for use with grill and convection ovens only. DO NOT use any metal accessories when using the microwave function.
- For use of the Grill Rack refer to the GRILL sections of this User Manual.

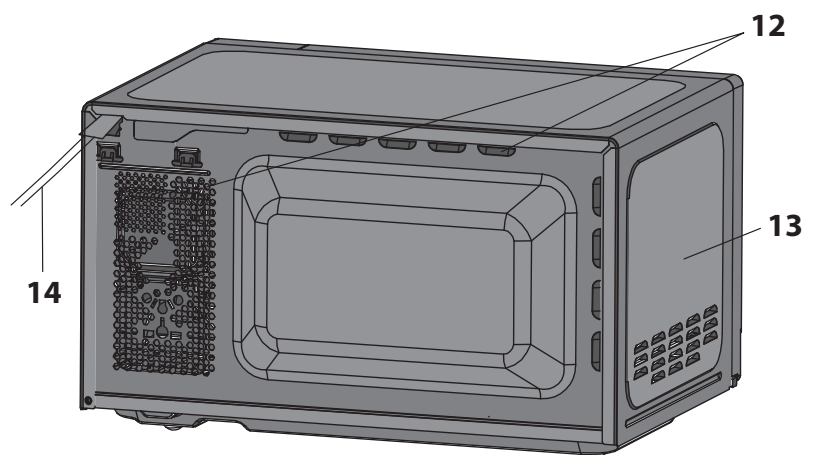
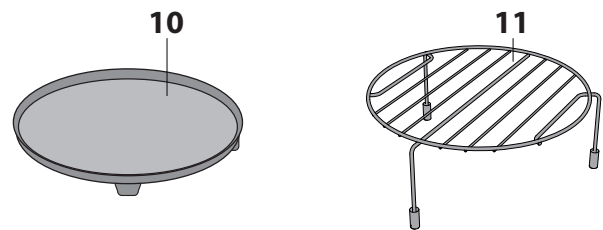

CONTROL PANEL -PC284A

1. **DIGITAL DISPLAY** – Cooking time, power, indicators and clock time are displayed.
2. **AUTO MENU keys** – Press to select auto cooking menu.
3. **START/QUICK START**
4. **MICROWAVE POWER** – Press to select microwave power level.
5. **GRILL** – Press to set grill cooking program.
6. **MICROWAVE+GRILL** – Press to set microwave and grill combination cooking program.
7. **CONVECTION TEMPERATURE** – Press to select convection temperature.
8. **MICROWAVE+CONVECTION** – Press to select convection ombination cooking.
9. **JOG DIAL** – Use to set time of cooking or the clock.
10. **STOP/ECO** – Press once to temporarily stop cooking, or twice to cancel cooking altogether. Use to set power saving mode.
11. **CHILD LOCK**
12. **TIME/SET CLOCK** – Use to set clock time. Use to set timer function.

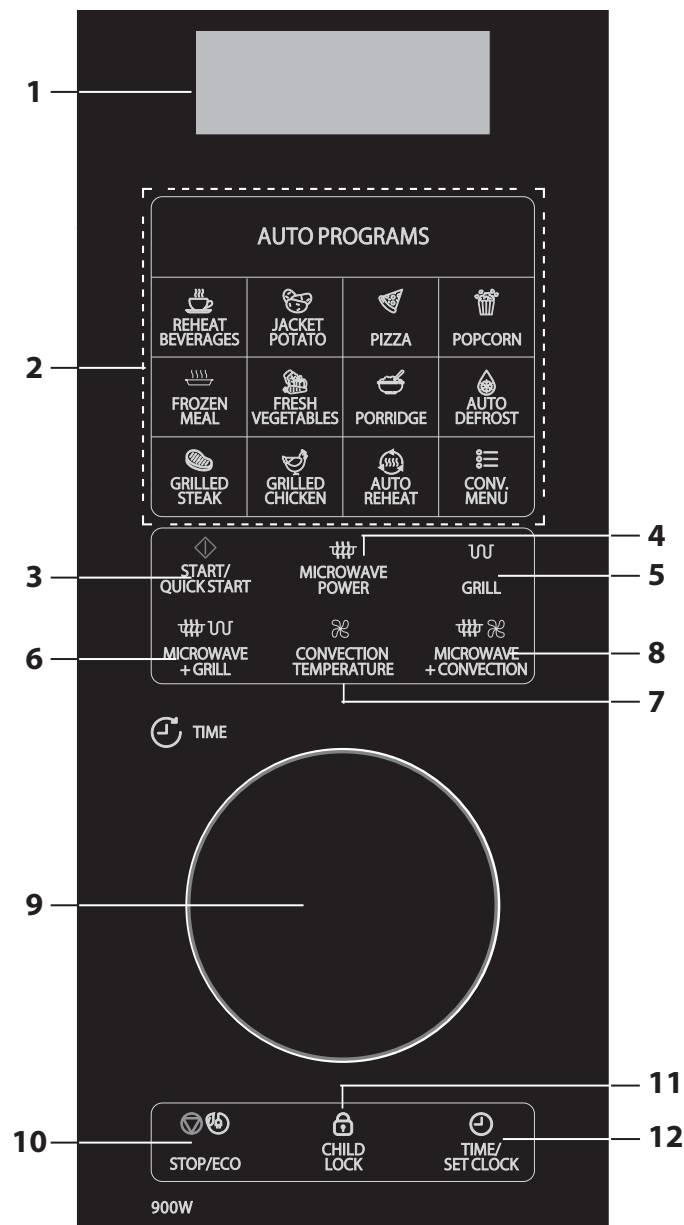

OPERATION SEQUENCE

OFF CONDITION

Closing the door activates the monitored latch switch and the latch switch A.

IMPORTANT:

When the oven door is closed, the contacts COM-NC of the monitor switch must be open. When the micro wave oven is plugged in a wall outlet (230V / 50Hz), the line voltage is supplied to the noise filter.

1. The control unit is energized. The display shows 1:00.
2. Open the door. The contacts (COM-NC) of the monitored latch switch are closed and the control unit is energized. Then contacts of relay RY2 are closed, RY1 and RY3 are opened, and the oven lamp will light.
3. Close the door. The contacts (COM-NC) of the monitored latch switch are opened and the contacts of relay RLY2 are opened and the oven lamp will be turned off.

MICROWAVE COOKING CONDITION HIGH COOKING

Enter a desired cooking time by rotating the knob, and start the oven by pushing the knob.

Function sequence

CONNECTED COMPONENTS	RELAY
Oven lamp, Turntable motor	RLY2
High voltage transformer	RLY6
Fan motor	RLY1

1. The line voltage is supplied to the primary winding of the high voltage transformer. The voltage is converted to about 3.3 volts A.C. output on the filament winding and high voltage of approximately 2000 volts A.C. on the secondary winding.
2. The filament winding voltage (3.3 volts) heats the magnetron filament and the high voltage (2000 volts) is sent to the voltage doubling circuit, where it is doubled to negative voltage of approximately 4000 volts D.C..
3. The 2450 MHz microwave energy produced in the magnetron generates a wavelength of 12.24 cm. This energy is channelled through the waveguide (transport channel) into the oven cavity, where the food is placed to be cooked.
4. When the cooking time is up, a signal tone is heard and the relays RY2 + RY6 + RY1 go back to their home position. The circuits to the oven lamp, high voltage transformer, fan motor and turntable motor are cut off.
5. When the oven door is opened during a cooking cycle, the switches come to the following condition.

Switch	Contact	Condition	
		During Cooking	Oven Door Open(No cooking)
Monitored latch switch	COM-NO	Closed	Opened
	COM-NC	Opened	Closed
Latch switch A	COM-NO	Closed	Opened
Latch switch B	COM-NO	Closed	Opened

The circuit to the high voltage transformer, fan motor, turntable motor and oven lamp are cut off when the latch switch A and latch switch B are made open.

6. MONITORED SWITCH

The monitored switch is mechanically controlled by the oven door, and monitors the operation of the latch switch A.

- 6-1. When the oven door is opened during or after the cycle of a cooking program, the latch switch A and latch switch B must open their contacts (COM-ON) firstly. And the contacts (COM-NC) of the monitored latch switch are made closed. After that the contacts (COM-NC) of the monitored switch can be closed.
- 6-2. When the oven door is closed, the contacts (COM-NC) of the monitored switch must be opened. After that the contacts of the latch switch A and latch switch B are closed.
- 6-3. When the oven door is opened and the contacts (COM-NO) of the monitored switch is opened, the contacts (COM-NC) of the monitored switch is closed, while the contacts (COM-NO) of the latch switch A remain closed, the fuse F1 F12A will blow.

HIGH, MEDIUM HIGH, MEDIUM, MEDIUM LOW, LOW COOKING

When the microwave oven is preset for variable cooking power, the line voltage is supplied to the high voltage transformer intermittently within a 33-second time base through the relay contact which is coupled with the current-limiting relay RY6. The following levels of microwave power are given.

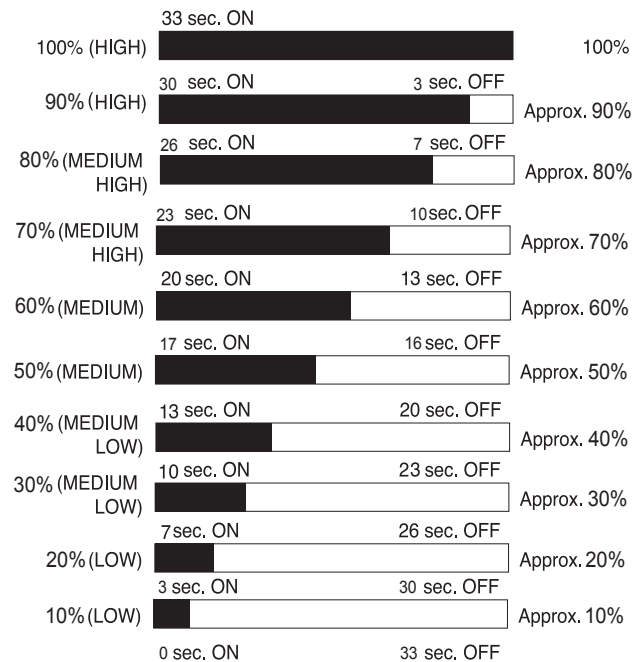

Note: The On/Off time ratio does not exactly correspond to the percentage of microwave power, because approx. 3 seconds are needed for heating up the magnetron filament.

OPERATION SEQUENCE

GRILL COOKING CONDITION

TOP GRILL

In this condition the food is cooked by the grill heating element. Programme the desired cooking time by pressing the Time +/- key and the Grill key. When the START/ QUICK START key is pressed, the following operations occur:

1. The numbers on the digital readout start the count down to zero.
2. The oven lamp, cooling fan motor and turntable motor are energized.
3. The grill relay RY5 is energized and the main supply voltage is applied to the top grill heating elements.
4. Now, the food is cooked by the top grill heating elements.

CONVECTION COOKING CONDITION

PRE-HEATING (by 110°C - 210°C)

Press the CONVECTION key.

Programme the desired convection temperature of 110°C - 210°C by pressing the CONVECTION key. When the START/+30S key is pressed, the following operations occur:

1. The relays RY2, RY1 and RY3 are energized, the oven lamp, stirrer motor, fan motor and convection motor are turned on.
2. The relay RY4 and RY5 are energized and the main supply voltage is applied to the convection heating element and the grill heating elements.
3. After the temperature of oven cavity rises to the selected one, the oven will continue to turn the grill heating element on and off to maintain the temperature for 30 minutes.

CONVECTION COOKING (by 110°C-210°C)

Programme the desired convection temperature of 110°C - 210°C by pressing the CONVECTION key. When the START/+30S key is pressed, the following operations occur:

1. The relays RY2, RY1 and RY3 are energized, the oven lamp, turntable motor, fan motor and convection motor are turned on.
2. The relay RY4 and RY5 are energized and the main supply voltage is applied to the convection heating element and the grill heating elements.
3. After the temperature of oven cavity rises to the selected one, the oven will continue to turn the grill heating element on and off to maintain the temperature for 30 minutes.

DUAL COOKING CONDITION

MICROWAVE AND CONVECTION

Programme the desired convection temperature 200°C by pressing the Microwave+Convection key. Programme the desired cooking time by rotating the Time/Weight knob. When the START/+30S key is pressed, the following operations occur:

1. The numbers on the digital read-out start the count down to zero.
2. The oven lamp, fan motor, turntable motor and convection motor are energized.
3. The relay RY4 will be energized and the main supply voltage is applied to the convection heating element.
4. The relay RY6 is energized and the microwave energy is generated by magnetron.
5. Now, the food is cooked by microwave and convection energy simultaneously.

MICROWAVE AND TOP GRILL

Programme the desired cooking mode by pressing the Microwave+Grill key. Programme the desired cooking time by rotating the Time/Weight knob. When the START/+30S key is pressed, the following operations occur:

1. The numbers on the digital read-out start the count down to zero.
2. The oven lamp, fan motor and turntable motor are energized.
3. The relay RY5 is energized and the main supply voltage is applied to the grill heating elements.
4. The relay RY6 is energized and the microwave energy is generated by magnetron.
5. Now, the food is cooked by microwave and grill simultaneously.

AUTOMATIC COOKING

Automatic cooking functions automatically work out the correct cooking mode and cooking time and/or cooking temperature. They will cook according to the special cooking sequence.

FUNCTION OF IMPORTANT COMPONENTS

DOOR OPEN MECHANISM

The door can be opened by pushing the open button.

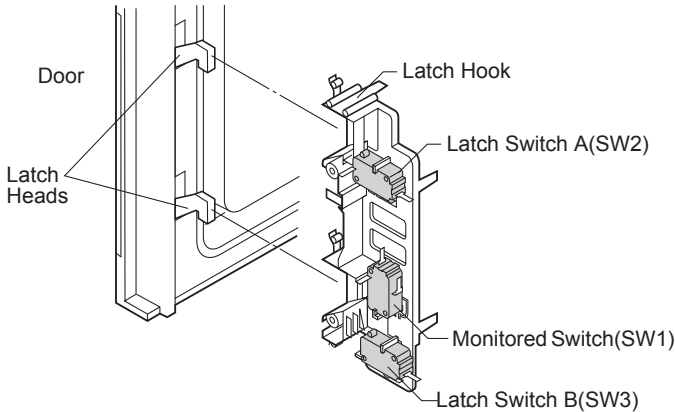

Figure D-1. Door Open Mechanism

MONITORED LATCH SWITCH SW1

1. When the oven door is closed, the contacts (COM-NO) of the switch must be closed. And the contacts (COM-NC) must be opened.
2. When the oven door is opened, the contacts (COM-NO) of the switch must be opened. And the contacts (COM-NC) must be closed.
3. When the oven door is opened and the contacts (COM-NO) of the monitored switch is opened, the contacts (COM-NC) of the monitored switch is closed, while the contacts (COM-NO) of the latch switch A remain closed, the fuse F1 F12A will blow.

CAUTION: BEFORE REPLACING A BLOWN FUSE F1 F12A, TEST THE MONITORED LATCH SWITCH SW1 AND LATCH SWITCH B SW2 FOR PROPER OPERATION. (REFER TO CHAPTER "TEST PROCEDURE").

LATCH SWITCH A SW2

1. When the oven door is closed, the contacts (COM-NO) of the switch must be closed.
2. When the oven door is opened, the contacts (COM-NO) of switch must be opened.

LATCH SWITCH B SW3

1. When the oven door is closed, the contacts (COM-NO) of the switch must be closed.
2. When the oven door is opened, the contacts (COM-NO) of switch must be opened.

HIGH VOLTAGE FUSE

The high voltage fuse blows when the high voltage rectifier or the magnetron is shorted.

FUSE F1 F8 A 220-240V

1. If the wire harness or electrical components are short-circuited, this fuse blows to prevent an electric shock or fire hazard.
2. The fuse also blows when the monitored latch switch SW1 remains closed with the oven door open and when the monitor switch SW3 contact (COM-NC) closes.
3. The fuse also blows when H.V.wire harness, H.V.capacitor, magnetron or secondary winding of high voltage transformer is shorted.

TC TRANSFORMER

T/C transformer converts A.C. line voltage into low voltage to drive the control unit.

THERMAL CUT-OUT TC1 140°C

The temperature fuse located on the top of the oven cavity is designed to prevent damage to the oven if the foods in the oven catch fire due to over heating produced by improper setting of cook time or failure of control unit. Under normal operation, the temperature fuse remains closed. However, when abnormally high temperatures are reached within the oven cavity, the temperature fuse will open at 140°C, causing the oven to shut down. The defective temperature fuse must be replaced with a new one.

THERMAL CUT-OUT TC2 180°C

This thermal cut-out protects the magnetron against overheat. If the temperature goes up higher than 180°C because the fan motor is interrupted, the ventilation openings are blocked, or the other abnormal matter occurs, the thermal cut-out TC2 opens and switches off all the electrical parts.

NOISE FILTER

The noise filter assembly prevents radio frequency interference that might flow back in the power circuit.

TURNTABLE MOTOR TTM

The turntable motor rotates the turntable.

FAN MOTOR FM

The fan motor drives a blade which draws external cool air. This cool air is directed through the air vanes surrounding the magnetron and cools the magnetron. This air is channelled through the oven cavity to remove steam and vapours given off from heating food. It is then exhausted through the exhausting air vents of the oven cavity.

CONVECTION MOTOR CM

The convection motor drives the convection fan and pro-

FUNCTION OF IMPORTANT COMPONENTS

GRILL HEATING ELEMENT

The grill heating elements are provided to brown the food and are located on the top of the oven cavity.

CONVECTION HEATING ELEMENT

The convection heating element situated at the top of the oven cavity. It is intended to heat air driven by the convection fan. The heated air is kept in the oven and force-circulated and reheated by the convection heating element.

CONVECTION COOKING SYSTEM

This oven is designed with a hot air heating system where food is heated by forced circulation of the hot air produced by the grill heaters and convection heaters. The air heated by the grill heating elements and convection heating elements is circulated through the convection passage provided on the outer casing of the oven cavity by means of the convection fan which is driven by the convection motor. It is then enters the inside of the oven through the vent holes provided on the top side of the oven. Next, the hot air heats the food on the turntable and leaves the oven cavity through the vent in the oven cavity rear wall.

In this way, the hot air circulates inside the oven cavity to raise its temperature and, at the same time, comes into contact with the food being cooked. When the temperature inside the oven cavity reaches the selected temperature, the heating elements are de-energized. When the temperature inside the oven cavity drops below the selected temperature, the heating elements are energized again. In this way, the inside of the oven cavity is maintained at approximately the selected temperature. When the convection time reaches "0", the heating elements are de-energized and the convection fan stops operating and the oven shuts off. At that time if oven has been working for more than 2 minutes, the fan motor remains rotating for 3 minutes to cool down the oven.

FIRE SENSING FEATURE

The oven will stop its operation and enter protection mechanism when the cavity temperature is super high or super low, or the sensor is short circuit.

1. If the temperature of the cavity exceed 230°C during working, the system will enter the super high protection mechanism, the display shows E01, press the "STOP/ECO" key to return the system to normal standby mode.
2. If the temperature of the cavity lower than 40°C after working under convection, convection combine, grill or grill combine for 5 minutes, the system will enter the super low protection mechanism, the display shows E02, press the "STOP/ECO" key to return the system to normal standby mode.
3. When the sensor is short circuit, if the PCB is proceeding the convection, convection combination, grill or grill combination cooking, the system will enter sensor faulty protection mechanism, the display shows E03, press the "STOP/ECO" key to return the system to normal standby mode.

TEST PROCEDURES

PROCEDURE LETTER	COMPONENT TEST
------------------	----------------

A MAGNETRON TEST

NEVER TOUCH ANY PART IN THE CIRCUIT WITH YOUR HAND OR AN INSULATED TOOL WHILE THE OVEN IS IN OPERATION.

CARRY OUT 3D CHECKS.

Isolate the magnetron from high voltage circuit by removing all leads connected to filament terminal.

To test for an open circuit filament use an ohmmeter to make a continuity test between the magnetron filament terminals, the meter should show a reading of less than 1 ohm.

To test for short filament to anode condition, connect ohmmeter between one of the filament terminals and the case of the magnetron (ground). This test should be indicated an infinite resistance. If a low or zero resistance reading is obtained then the magnetron should be replaced.

MICROWAVE OUTPUT POWER (IEC-705-1988)

The following test procedure should be carried out with the microwave oven in a fully assembled condition (outer case fitted). Microwave output power from the magnetron can be measured by way of IEC 60705, i.e. it is measured by how much power the water load can absorb. To measure the microwave output power in the microwave oven, the relation of calorie and watt is used. When P(W) heating works for t(second), approximately $P \times t / 4.187$ calorie is generated. On the other hand, if the temperature of the water with V(ml) rises ΔT (°C) during this microwave heating period, the calorie of the water is $V \times \Delta T$.

The formula is as follows;	
$P \times t / 4.187 = V \times \Delta T + 0.55 \times mc (T_2 - T_0)$	$P (W) = 4.187 \times V \times \Delta T / t + 0.55 \times mc (T_2 - T_0) / t$
Our condition for water load is as follows:	
Room temperature (T ₀).....around 20°C	Power supply Voltage Rated voltage
Water load 1000 g	Initial temperature (T ₁).....10±1°C
Heating time 47 sec.	Mass of container (mc)330 g
T ₂ Final Temperature	$P = 90 \times \Delta T + 0.55 \times mc (T_2 - T_0) / 47$

Measuring condition:

1. Container
The water container must be a cylindrical borosilicate glass vessel having a maximum material thickness of 3 mm and an outside diameter of approximately 190 mm.
2. Temperature of the oven and vessel
The oven and the empty vessel are at ambient temperature prior to the start the test.
3. Temperature of the water
The initial temperature of the water is (10±2)°C.
4. Select the initial and final water temperature so that the maximum difference between the final water temperature and the ambient temperature is 5K.
5. Select stirring devices and measuring instruments in order to minimize addition or removal of heat.
6. The graduation of the thermometer must be scaled by 0.1°C at minimum and be an accurate thermometer.
7. The water load must be (1000±5) g.
8. "t" is measured while the microwave generator is operating at full power. Magnetron filament heat-up time is not included.

NOTE: The operation time of the microwave oven is "t + 3" sec. (3 sec. is magnetron filament heat-up time.)

Measuring method:

1. Measure the initial temperature of the water before the water is added to the vessel.
(Example: The initial temperature T₁ = 11°C)
2. Add the 1 litre water to the vessel.
3. Place the load on the centre of the shelf.
4. Operate the microwave oven at HIGH for the temperature of the water rises by a value ΔT of (10 ± 2) K.
5. Stir the water to equalize temperature throughout the vessel.
6. Measure the final water temperature. (Example: The final temperature T₂ = 21°C)
7. Calculate the microwave power output P in watts from above formula.

TEST PROCEDURES

**PROCEDURE
LETTER**

COMPONENT TEST

Room temperature $T_o = 21^\circ\text{C}$ Initial temperature..... $T_1 = 11^\circ\text{C}$
 Temperature after $(47 + 3) = 50$ sec..... $T_2 = 21^\circ\text{C}$
 Temperature difference Cold-Warm $\Delta T_1 = 10^\circ\text{C}$
 Measured output power
 The equation is " $P = 90 \times \Delta T$ " $P = 90 \times 10^\circ\text{C} = 900$ Watts

JUDGMENT: The measured output power should be at least $\pm 15\%$ of the rated output power.

CAUTION: 1°C CORRESPONDS TO 90 WATTS. REPEAT MEASUREMENT IF THE POWER IS INSUFFICIENT.

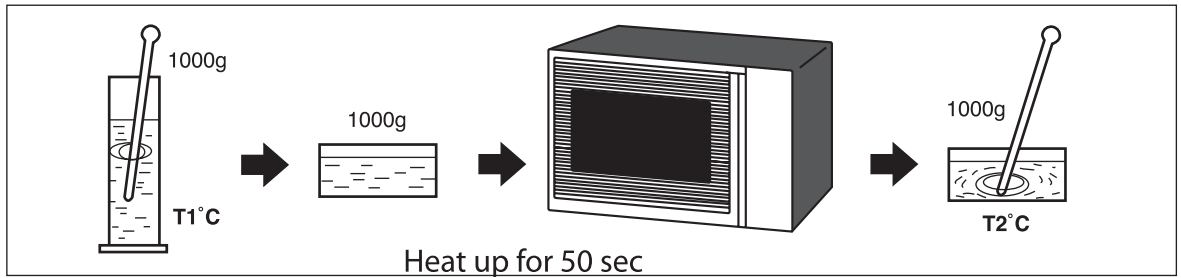

B HIGH VOLTAGE TRANSFORMER TEST

WARNING: High voltage and large currents are present at the secondary winding and filament winding of the high voltage transformer. It is very dangerous to work near this part when the oven is on. NEVER make any voltage measurements of the high-voltage circuits, including the magnetron filament.

CARRY OUT 3D CHECKS.

Disconnect the leads to the primary winding of the high voltage transformer. Disconnect the filament and secondary winding connections from the rest of the HV circuitry. Using an ohmmeter, set on a low range, it is possible to check the continuity of all three winding. The following readings should be obtained:

- a. Primary winding approximately 1.7Ω
- b. Secondary winding..... approximately 172Ω
- c. Filament winding approximately 0.4Ω

If the readings obtained are not stated as above, then the high voltage transformer is probably faulty and should be replaced.

CARRY OUT 4R CHECKS.

C HIGH VOLTAGE CAPACITOR TEST

CARRY OUT 3D CHECKS.

- A. Isolate the high voltage capacitor from the circuit.
- B. Continuity check must be carried out with measuring instrument which is set to the highest resistance range.
- C. A normal capacitor shows continuity for a short time (kick) and then a resistance of about $10\text{M}\Omega$ after it has been charged.
- D. A short-circuited capacitor shows continuity all the time.
- E. An open capacitor constantly shows a resistance about $10 \text{M}\Omega$ because of its internal $10\text{M}\Omega$ resistance.
- F. When the internal wire is opened in the high voltage capacitor shows an infinite resistance.
- G. The resistance across all the terminals and the chassis must be infinite when the capacitor is normal.

If incorrect reading are obtained, the high voltage capacitor must be replaced.

CARRY OUT 4R CHECKS.

D HIGH VOLTAGE FUSE TEST

CARRY OUT 3D CHECKS.

If the high voltage fuse is blown, there could be a short in the high voltage rectifier or the magnetron. Check them and replace the defective parts and the high voltage fuse.

CARRY OUT 4R CHECKS.

CAUTION: ONLY REPLACE HIGH VOLTAGE FUSE WITH THE CORRECT VALUE REPLACEMENT.

TEST PROCEDURES

**PROCEDURE
LETTER**

COMPONENT TEST

E HIGH VOLTAGE DIODE

CARRY OUT 3D CHECKS.

Isolate the high voltage diode from the HV circuit. The high voltage diode can be tested using an ohmmeter set to its highest range. Connect the ohmmeter across the terminals "+" "-" of the high voltage diode and note the reading obtained. Reverse the meter leads and note this second reading. The normal resistance is infinite in one direction and more than 100 kΩ in the other direction.

CARRY OUT 4R CHECKS.

F SWITCH TEST

CARRY OUT 3D CHECKS.

Disconnect the leads from the motor. Using an ohmmeter, check the resistance between the two terminals as described in the table below.

Table: Terminal Connection of Switch

Plunger Operation	COM to NO	COM to NC	COM; Common terminal,
Released	Open circuit	Short circuit	NO; Normally open terminal
Depressed	Short circuit	Open circuit	NC; Normally close terminal

If incorrect readings are obtained, make the necessary switch adjustment or replace the switch.

CARRY OUT 4R CHECKS.

G THERMAL CUT-OUT TEST

CARRY OUT 3D CHECKS.

Disconnect the leads from the terminals of the thermal cut-out. Then using an ohmmeter, make a continuity test across the two terminals as described in the below.

Table: Thermal Cut-out Test

Parts Name	Temperature of "ON" condition (closed circuit). (°C)	Temperature of "OFF" condition (open circuit). (°C)	Indication of ohmmeter (When room temperature is approx. 20°C.)
Thermal cut-out <u>TC1</u> 140°C	Below 140°C	Above 140°C	Closed circuit
Thermal cut-out <u>TC2</u> 180°C	Below 180°C	Above 180°C	Closed circuit

If incorrect readings are obtained, replace the thermal cut.

An open circuit thermal cut-out TC1 indicates that the oven cavity has overheated, this may be due to no load operation, foods in the oven catch fire.

An open circuit thermal cut-out TC2 indicates that the magnetron has overheated, this may be due to restricted ventilation, cooling fan failure.

CARRY OUT 4R CHECK

H MOTOR WINDING TEST

CARRY OUT 3D CHECKS.

Disconnect the leads from the motor Using an ohmmeter check the resistance between the two terminals as described in the below.

Table: Resistance of Motor

Motors	Resistance
Fan motor	Approximately 400Ω
Turntable motor	Approximately 15 kΩ

If incorrect readings are absorbed, replace the motor.

CARRY OUT 4R CHECKS.

TEST PROCEDURES

**PROCEDURE
LETTER**

COMPONENT TEST

I NOISE FILTER TEST

CARRY OUT 3D CHECKS.

Disconnect the leads from the terminals of noise filter.
Using an ohmmeter, check between the terminals as described in the following table.

MEASURING POINTS	INDICATION OF OHMMETER
Between N and L	Open circuit
Between terminal N and WHITE	Short circuit
Between terminal L and RED	Short circuit

If incorrect readings are absorbed, replace the noise filter unit.

CARRY OUT 4R CHECKS.

J BLOWN FUSE F1 F12A

CARRY OUT 3D CHECKS.

1. If the fuse F1 F12A is blown when the door is opened, check the monitored latch switch SW1 and latch switch B SW2.
2. If the fuse F1 F12A is blown by incorrect door switching replace the defective switch(es) and the fuse F1 F12A
3. If the fuse F1 F12A is blown, there should be electrical components are short-circuited or there is a ground in wire harness. Check the electrical components and replace the defective parts or repair the wire harness.

CARRY OUT 4R CHECKS.

CAUTION: Only replace fuse F1 F12A with the correct value replacement.

K GRILL HEATING ELEMENTS AND CONVECTION HEATING ELEMENT TEST

CARRY OUT 3D CHECKS.

Before carrying out the following tests make sure the heating element is cool completely.

1. Resistance of heating element.

Disconnect the wire leads to the heating element to be tested. Using ohmmeter with low resistance range. Check the resistance across the terminals of the heating element as described in the following table.

Table: Resistance of heating element

Parts name	Resistance
Grill heating elements	Approximately 47 Ω
Convection heating elements	Approximately 65 Ω

2. Insulation resistance.

Disconnect the wire leads to the heating element to be tested. Check the insulation resistance between the element terminal and cavity using a 500V - 100MΩ insulation tester. The insulation resistance should be around 10MΩ in the cold start.

If the results of above test 1 and/or 2 are out of above specifications, the heating element is probably faulty and should be replaced.

CARRY OUT 4R CHECKS.

TEST PROCEDURES

PROCEDURE LETTER

COMPONENT TEST

L **CONTROL PANEL ASSEMBLY TEST**

The control panel consists of circuits including semiconductors such as LSI, ICs, etc. Therefore, unlike conventional microwave ovens, proper maintenance can not be performed with only a voltmeter and ohmmeter.

In this service manual, the control panel assembly is divided into two units, Control Unit and Key Unit, and also the control unit is divided into two units, CPU unit and Power unit, and troubleshooting by replacement is described according to the symptoms indicated.

1. Key Unit

The following symptoms indicate a defective key unit.

- a) When touching the keys, a certain key produces no signal at all.
- b) When touching the keys, sometimes a key produces no signal.
- c) When touching one key, other keys produce signal.
- d) Without touching the keys, sometimes a key produces signal.

2. Control Unit

The following symptoms indicate a defective control unit. Before replacing the control unit, perform the Key unit test to determine if control unit is faulty.

2-1 In connection with keys

- a) When touching the keys, a certain group of keys do not produce a signal.
- b) When touching the keys, no keys produce a signal.

2-2 In connection with indicators

- a) At a certain digit, all or some segments do not light up.
- b) At a certain digit, brightness is low.
- c) Only one indicator does not light up.
- d) The corresponding segments of all digits do not light up; or they continue to light up.
- e) Wrong figure appears.
- f) A certain group of indicators do not light up.
- g) The figure of all digits flicker.

3. Other possible troubles caused by defective control unit.

- a) Buzzer does not sound or continues to sound.
- b) Clock does not operate properly.
- c) Cooking is not possible.

M **PCB ERROR CODE**

E01: Super high temperature protection. When the cavity temperature is higher than 250C, the oven will enter the super high temperature protection, the display shows E01, and the buzzer makes DE sound.

E02: Super low temperature protection. When the oven continuously runs convection, convection combi., grill or grill combi. for more than 5 mins, if the cavity temperature is less than 40C, the oven will enter the super low temperature protection, the display shows E02, and the buzzer makes DE sound.

E03: Sensor fault protection. When the sensor is short circuit, if the PCB is proceeding the convection, convection combination, grill or grill combination cooking, the system will enter sensor fault protection. The display shows E03, and the buzzer makes DE sound.

If the display shows above error code, it's probably some problem with the cooling system, reheating system or sensor.

TEST PROCEDURES

**PROCEDURE
LETTER**

COMPONENT TEST

N RELAY TEST

CARRY OUT 3D CHECKS

Remove the outer case and check voltage between Pin Nos. 1 and 3 of the 4 pin connector (E) on the control unit with an A.C. voltmeter.

The meter should indicate 230 volts, if not check oven circuit.

Relay Test

Check voltage at the relay coil with a D.C. voltmeter during the microwave cooking operation, grill operation, convection operation or dual operation.

DC. voltage indicated Defective relay.

DC. voltage not indicated Check diode which is connected to the relay coil. If diode is good, control unit is defective.

control unit is defective.

RELAY SYMBOL	OPERATIONAL VOLTAGE	CONNECTED COMPONENTS
RY1	Approx. 12V D.C.	Fan motor
RY2	Approx. 12V D.C.	Oven lamp, Stirrer Motor
RY3	Approx. 12V D.C.	Convection motor
RY4	Approx. 12V D.C.	Convection heating element
RY5	Approx. 12V D.C.	Grill heating element
RY6	Approx. 12V D.C.	High voltage transformer

CARRY OUT 4R CHECK

O PROCEDURES TO BE TAKEN WHEN THE FOIL PATTERN ON THE PRINTED WIRING BOARD (PWB) IS OPEN

To protect the electronic circuits, this model is provided with a fine foil pattern added to the input circuit on the PWB, this foil pattern acts as a fuse. If the foil pattern is open, follow the troubleshooting guide given below for repair.

Problem: POWER ON, indicator does not light up.

CARRY OUT 3D CHECKS.

STEPS	OCCURRENCE	CAUSE OR CORRECTION
1	The rated AC voltage is not present between Pin Nos. 1 and 2 of the 3-pin connector (E).	Check supply voltage and oven power cord.
2	The rated AC voltage is present at primary side of low voltage transformer.	Low voltage transformer or secondary circuit defective. Check and repair.

NOTE: *At the time of these repairs, make a visual inspection of the varistor for burning damage and examine the transformer with tester for the presence of layer short circuit (check primary coil resistance). If any abnormal condition is detected, replace the defective parts.

CARRY OUT 4R CHECKS.

CONTROL PANEL ASSEMBLY

OUTLINE OF JOG CONTROL PANEL

The control section consists of the following units as shown in the jog control panel circuit.

- (1) Key Unit
- (2) Control Unit (The Control unit consists of Power unit and CPU unit.)

The principal functions of these units and signals communicated among them are explained below.

Key Unit

The key unit is composed of a matrix, signals generated in the LSI are sent to the key unit.

When a key pad is touched, a signal is completed through the key unit and passed back to the LSI to perform the function that was requested.

Control Unit

Control unit consists of LSI, power source circuit, synchronizing signal circuit, ACL circuit, buzzer circuit, relay circuit, temperature measurement circuit, indicator circuit.

1) LSI

This LSI controls the key strobe signal, really driving driving signal for oven function and indicator signal.

2) Power Source Circuit

This circuit generates voltage necessary in the control unit.

Symbol Voltage Application		
VC	5.0V	LSI(IC1)

3) Synchronizing Signal Circuit

The power source synchronizing signal is available in order to compose a basic standard time in the clock circuit. It accompanies a very small error because it works on commercial frequency.

4) ACL

A circuit to generate a signal which resets the LSI to the initial state when power is supplied.

5) Buzzer Circuit

The buzzer is responsive to signals from the LSI to emit audible sounds (key touch sound and completion sound).

6) Door Sensing Switch (Latch Switch B)

A switch to "tell" the LSI if the door is open or closed.

7) Relay Circuit

To drive the magnetron, grill heating element, convection heating element, convection motor, fan motor, turntable motor and light the oven lamp.

8) Indicator Circuit

This circuit consists 9-segments and 5-common electrodes using a LED.

SERVICING

1. Precautions for Handling Electronic Components

This unit uses CMOS LSI in the integral part of the circuits. When handling these parts, the following precautions should be strictly followed. CMOS LSI have extremely high impedance at its input and output terminals. For this reason, it is easily influenced by the surrounding high voltage power source, static electricity charge in clothes, etc., and sometimes it is not fully protected by the built-in protection circuit.

In order to protect CMOS LSI.

- 1) When storing and transporting, thoroughly wrap them in aluminium foil. Also wrap PW boards containing them in aluminium foil.
- 2) When soldering, ground the technician as shown in the figure and use grounded soldering iron and work table.

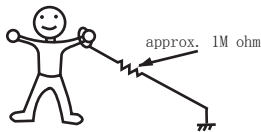

2. Servicing of Touch Control Panel

We describe the procedures to permit servicing of the touch control panel of the microwave oven and the precautions you must take when doing so.

To perform the servicing, power to the touch control panel is available either from the power line of the oven itself or from an external power source.

(1) Servicing the touch control panel with power supply of the oven :

CAUTION:

THE HIGH VOLTAGE TRANSFORMER OF THE MICROWAVE OVEN IS STILL LIVE DURING SERVICING AND PRESENTS A HAZARD .

Therefore, before checking the performance of the touch control panel,

- 1) Disconnect the power supply cord, and then remove outer case.
- 2) Open the door and block it open.
- 3) Discharge high voltage capacitor.
- 4) Disconnect the leads to the primary of the power transformer.
- 5) Ensure that these leads remain isolated from other components and oven chassis by using insulation tape.
- 6) After that procedure, re-connect the power supply cord.

After checking the performance of the touch control panel,

- 1) Disconnect the power supply cord.
- 2) Open the door and block it open.
- 3) Re-connect the leads to the primary of the power transformer.

- 4) Re-connect the outer case (cabinet).
- 5) Re-connect the power supply cord after the outer case is installed.
- 6) Run the oven and check all functions.

A. On some models, the power supply cord between the touch control panel and the oven itself is so short that the two can't be separated.

For those models, check and repair all the controls (sensor-related ones included) of the touch control panel while keeping it connected to the oven.

B. On some models, the power supply cord between the touch control panel and the oven is long enough that they may be separated from each other. For those models, therefore, it is possible to check and repair the controls of the touch control panel while keeping it apart from the oven; in this case you must short both ends of the door sensing switch (on PWB) of the touch control panel with a jumper, which brings about an operational state that is equivalent to the oven door being closed. As for the sensor-related controls of the touch control panel, checking them is possible if the dummy resistor(s) with resistance equal to that of the controls are used.

(2) Servicing the touch control panel with power supply from an external power source:

Disconnect the touch control panel completely from the oven, and short both ends of the door sensing switch (on PWB) of the touch control panel, which brings about an operational state that is equivalent to the oven door being closed. Connect an external power source to the power input terminal of the touch control panel, then it is possible to check and repair the controls of the touch control panel; it is also possible to check the sensor-related controls of the touch control panel by using the dummy resistor(s).

3. Servicing Tools

Tools required to service the touch control panel assembly.

- 1) Soldering iron: 30W
(It is recommended to use a soldering iron with a grounding terminal.)
- 2) Oscilloscope: Single beam, frequency range: DC - 10MHz type or more advanced model.
- 3) Others: Hand tools

4. Other Precautions

- 1) Before turning on the power source of the control unit, remove the aluminium foil applied for preventing static electricity.
- 2) Connect the connector of the key unit to the control unit being sure that the lead wires are not twisted.
- 3) After aluminium foil is removed, be careful that abnormal voltage due to static electricity etc. is not applied to the input or output terminals.
- 4) Attach connectors, electrolytic capacitors, etc. to PWB, making sure that all connections are tight.
- 5) Be sure to use specified components where high precision is required.

PRECAUTIONS FOR USING LEAD-FREE SOLDER

1. Employing lead-free solder

The "Control, Switch, LED, and Relay PWB" of this model employ lead-free solder. This is indicated by the "LF" symbol printed on the PWB and in the service manual. The suffix letter indicates the alloy type of the solder.

Example:

LFa
Sn-Ag-Cu

Indicates lead-free solder of tin, silver and copper.

2. Using lead-free wire solder

When repairing a PWB with the "LF" symbol, only lead-free solder should be used. (Using normal tin/lead alloy solder may result in cold soldered joints and damage to printed patterns.)

As the melting point of lead-free solder is approximately 40°C higher than tin/lead alloy solder, it is recommend that a dedicated bit is used, and that the iron temperature is adjusted accordingly.

3. Soldering

As the melting point of lead-free solder (Sn-Ag-Cu) is higher and has poorer wettability, (flow), to prevent damage to the land of the PWB, extreme care should be taken not to leave the bit in contact with the PWB for an extended period of time. Remove the bit as soon as a good flow is achieved. The high content of tin in lead free solder will cause premature corrosion of the bit. To reduce wear on the bit, reduce the temperature or turn off the iron when it is not required.

Leaving different types of solder on the bit will cause contamination of the different alloys, which will alter their characteristics, making good soldering more difficult. It will be necessary to clean and replace bits more often when using lead-free solder. To reduce bit wear, care should be taken to clean the bit thoroughly after each use.

COMPONENT REPLACEMENT AND ADJUSTMENT PROCEDURE

WARNING: Avoid possible exposure to microwave energy. Please follow the instructions below before operating the oven.

1. Disconnect oven from power supply.
2. Make sure that a definite "click" can be heard when the microwave oven door is unlatched. (Hold the door in a closed position with one hand, then push the door open button with the other, this causes the latch leads to rise, it is then possible to hear a "click" as the door switches operate.)
3. Visually check the door and cavity face plate for damage (dents, cracks, signs of arcing etc.).

Carry out any remedial work that is necessary before operating the oven.

Do not operate the oven if any of the following conditions exist;

1. Door does not close firmly.
2. Door hinge, support or latch hook is damaged.
3. The door gasket or seal is damaged.
4. The door is bent or warped.
5. There are defective parts in the door interlock system.
6. There are defective parts in the microwave generating and transmission assembly.
7. There is visible damage to the oven.

Do not operate the oven:

1. Without the RF gasket (Magnetron).
2. If the wave guide or oven cavity are not intact.
3. If the door is not closed.
4. If the outer case (cabinet) is not fitted.

Please refer to 'OVEN PARTS, CABINET PARTS, CONTROL PANEL PARTS, DOOR PARTS', when carrying out any of the following removal procedures:

WARNING FOR WIRING

To prevent an electric shock, take the following these procedures.

1. Before wiring,
 - 1) Disconnect the power supply.
 - 2) Open the door and wedge the door open.
 - 3) Discharge the high voltage capacitor and wait for 60 seconds.
2. Don't let the wire leads touch to the following parts;
 - 1) High voltage parts:
Magnetron, High voltage transformer, High voltage capacitor and High voltage rectifier assembly.
 - 2) Hot parts:
Oven lamp, Magnetron, High voltage transformer, Oven cavity, Grill heating element and Convection heating element.
 - 3) Sharp edge:
Bottom plate, Oven cavity, Waveguide flange, Chassis support and other metallic plate.
 - 4) Movable parts (to prevent a fault)
Fan blade, Fan motor, Switch, Turntable motor, Convection motor, convection fan and cooling fan.
3. Do not catch the wire leads in the outer case cabinet.
4. Insert the positive lock connector certainly until its pin is locked. And make sure that the wire leads should not come off even if the wire leads is pulled.
5. To prevent an error function, connect the wire leads correctly, referring to the Pictorial Diagram.

COMPONENT REPLACEMENT AND ADJUSTMENT PROCEDURE

OUTER CASE REMOVAL

To remove the outer case proceed as follows.

1. Disconnect oven from power supply.
2. Open the oven door and wedge it open.
3. Remove the four (4) screws holding the air duct.
4. Remove the air duct.
5. Remove the seven (7) screws from right side, rear and along the side edge of case.
6. Slide the entire case back about 3 cm to free it from retaining clips on the cavity face plate.
7. Lift the entire case from the oven.
8. Discharge the H.V. capacitor before carrying out any further work.
9. Do not operate the oven with the outer case removed.

N.B.; Step 1, 2 and 8 form the basis of the 3D checks.

CAUTION: DISCHARGE HIGH VOLTAGE CAPACITOR BEFORE TOUCHING ANY OVEN COMPONENT OR WIRING.

HIGH VOLTAGE COMPONENTS REMOVAL (HIGH VOLTAGE CAPACITOR , HIGH VOLTAGE FUSE AND HIGH VOLTAGE DIODE)

To remove the components, proceed as follows.

1. CARRY OUT 3D CHECKS.
2. Disconnect the filament lead of the high voltage transformer and the high voltage wire of the high voltage transformer from the high voltage capacitor.
3. Disconnect the high voltage wire from the magnetron.
4. Disconnect the high voltage fuse from the high voltage transformer.
5. Release the capacitor holder from the base plate.
6. Remove the high voltage capacitor from the capacitor holder.
7. Disconnect the high voltage fuse from the high voltage capacitor.
8. Disconnect the high voltage diode from the high voltage capacitor.
9. Remove the screw holding the high voltage diode to the base plate.
10. Now, the high voltage fuse , the high voltage capacitor and high voltage diode should be free.

HIGH VOLTAGE TRANSFORMER REMOVAL

1. CARRY OUT 3D CHECKS.
2. Disconnect the main wire harness from the high voltage transformer.
3. Disconnect the filament leads and high voltage wire of high voltage transformer from high voltage capacitor and the magnetron.
4. Remove the four(4) screws that holding the transformer to the base plate.
5. Remove the transformer.
6. Now the high voltage transformer is free.

MAGNETRON REMOVAL

CARRY OUT 3D CHECKS.

2. Remove the one(1) screw that holding the oven lamp, disconnect the wire harness from the oven lamp.
3. Remove the one(1) screw on the top of the air duct, remove the one(1) screw holding the thermostat and disconnect the wire harness from the thermostat.
4. Disconnect the H.V wire from the magnetron.
5. Turn oven the microwave oven and remove the one(1) screw on the bottom of the air duct, release the air duct.
6. Remove the two(2) screws holding the magnetron to the waveguide, when removing the screws hold the magnetron to prevent it from falling.
7. Remove the magnetron from the waveguide with care so the magnetron antenna is not hit by any metal object around the antenna.
8. Now, the magnetron is free.

CAUTION: WHEN REPLACING THE MAGNETRON, BE SURE THE R.F. GASKET IS IN PLACE AND THE MAGNETRON MOUNTING SCREWS ARE TIGHTENED SECURELY.

COMPONENT REPLACEMENT AND ADJUSTMENT PROCEDURE

CONTROL PANEL ASSEMBLY REMOVAL

1. CARRY OUT 3D CHECKS.
2. Disconnect the wire leads and the connectors from the control unit.
3. Remove the one (1) screw holding the control panel to the oven cavity face plate.
4. Lift up the control panel assembly and pull it forward. Now the control panel assembly is free.

NOTE:

1. Before attaching a new key unit, wipe off remaining adhesive on the control panel frame surfaces completely with a soft cloth soaked in alcohol.
2. When attaching the key unit to the control panel frame, adjust the upper edge and right edge of the key unit to the correct position of control panel frame.
3. Stick the key unit firmly to the control panel frame by rubbing with soft cloth not to scratch.

FAN MOTOR REPLACEMENT

REMOVAL

1. CARRY OUT 3D CHECKS.
2. Remove the two(2) screws holding the noise filter fan assembly support.
3. Release the noise filter.
4. Remove the two(2) screws holding the fan duct to the oven cavity rear plate.
5. Disconnect the wire leads from the fan duct.
6. Release the fan duct from the oven.
7. Remove the fan blade from the fan motor shaft according to the following procedure.
 - 1) Hold the edge of the rotor of the fan motor by using a pair of groove joint pliers.

CAUTION:

- Make sure that no swarf from the rotor enters the gap between the rotor & stator of the fan motor.
- Avoid touch the coil of the fan motor with the pliers as the coil may become cut or damaged.
- Avoid deforming the bracket whilst using the pliers.

- 2) Remove the fan blade assembly from the shaft of the fan motor by pulling and rotating the fan blade with your hand.
- 3) Now, the fan blade is free.

CAUTION:

- Do not re-use the removed fan blade as the fixing hole may be oversized.

8. Remove the two(2) screws holding the fan motor to the fan duct.
9. Now, the fan motor is free.

INSTALLATION

1. Install the the fan blade to the fan motor shaft according to the following procedure.
2. Hold the center of the bracket which supports the shaft of the fan motor on the flat table.
3. Apply the screw lock tight into the hole(for shaft) of the fan blade.
4. Install the fan blade to the shaft of fan motor by pushing the fan blade with a small, light weight, ball peen hammer or rubber mallet.

CAUTION: DO NOT HIT THE FAN BLADE STRONGLY WHEN INSTALLED BECAUSE THE BRACKET MAY BE TRANSFORMED.

MAKE SURE THAT THE FAN BLADE ROTATES SMOOTH AFTER INSTALLED.

MAKE SURE THAT THE AXIS OF THE SHAFT IS NOT SLANTED.

5. Install the fan motor assembly to the fan duct with two(2) screws.
6. Install the fan assembly to the oven cavity back plate with two(2) screws.
7. Connect the wire leads to the magnetron and fan motor, referring to the pictorial diagram.

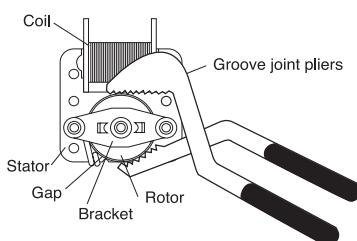

Rear view

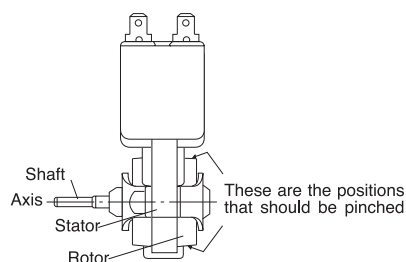

Side view

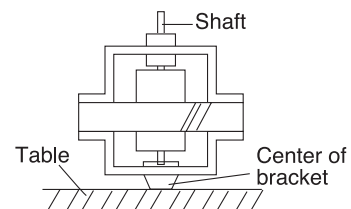

COMPONENT REPLACEMENT AND ADJUSTMENT PROCEDURE

TURNTABLE MOTOR REPLACEMENT

Removal

1. Disconnect the oven from the power supply.
2. Remove the turntable and roller stay from the oven cavity.
3. Turn the oven over.
4. Cut the four (4) bridges holding the turntable motor cover to the base plate with cutting pliers as shown in Figure C-1(a).

CAUTION: DO NOT DROP THE TURNTABLE MOTOR COVER INTO THE OVEN AFTER CUTTING THE BRIDGES. BECAUSE IT WILL DAMAGE THE WIRE LEADS OF THE MOTOR AND IT IS DIFFICULT TO REMOVE IT OUT OF THE OVEN.

5. Remove the turntable motor cover from the base plate.
6. Disconnect the wire leads from the turntable motor.

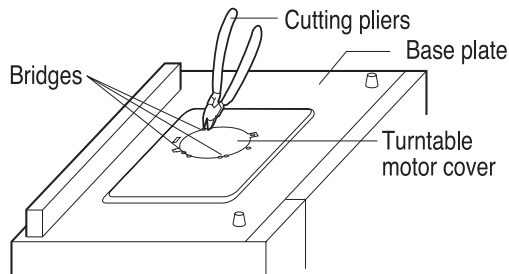

Figure C-1(a). Turntable motor cover removal

7. Remove the one(1) screw holding the turntable motor to the oven cavity back plate.
8. Remove the turntable motor from the turntable motor angle. Now, the turntable motor is free.

Re-install

1. Remove the any sharp edges on the turntable motor cover and the base plate with the cutting pliers.
2. Re-install turntable motor by locating shaft onto coupling to the oven cavity base plate with the one (1) screw.
3. Re-connect the wire leads to the turntable motor.
4. Insert the one (1) tab of the turntable motor cover into the slit of the base plate as shown in Figure C-1(b).
5. Re-install the turntable motor cover to the base plate with the screw as shown in Figure C-1(b).

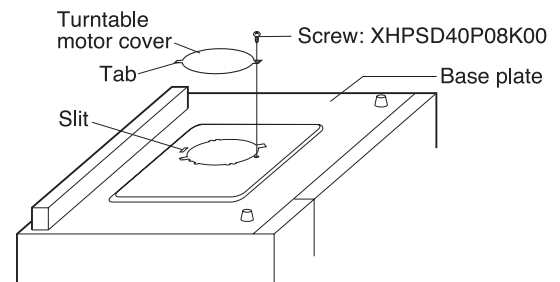

Figure C-1(b). Turntable motor cover re-install

POSITIVE LOCK® CONNECTOR REMOVAL

1. CARRY OUT 3D CHECKS.
2. Push the lever of positive lock® connector.
3. Pull down on the positive lock® connector.

CAUTION: WHEN YOU (SERVICE ENGINEERS)

CONNECT THE POSITIVE LOCK® CONNECTORS TO THE TERMINALS, CONNECT THE POSITIVE LOCK® SO THAT THE LEVER FACES YOU(SERVICE ENGINEERS).

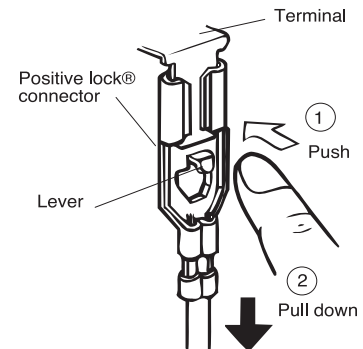

Figure C-2. Positive lock®connector

OVEN LAMP REMOVAL

1. CARRY OUT 3D CHECKS.
2. Remove the wire leads as Positive lock® connector removal above.
3. Lift up the oven lamp from its retaining clips by pushing the tab of the air intake duct.
4. Now, the oven lamp is free.

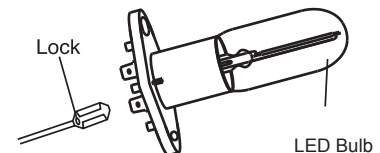

Figure C-3. Oven lamp

GRILL HEATING ELEMENTS REMOVAL

1. CARRY OUT 3D CHECKS.
2. Remove the two(2) screws holding the heat resistant board.
3. Dis connect the wire leads from the terminals of the two(2) grill heating elements.
4. Remove the grill heating elements bracket.
5. Take out the two(2) grill heating elements.
6. Now, the grill heating elements are free.

COMPONENT REPLACEMENT AND ADJUSTMENT PROCEDURE

POWER SUPPLY CORD REPLACEMENT

Removal

1. CARRY OUT 3D CHECKS.
2. Remove the one (1) screw holding the green/yellow wire to the back plate.
3. Disconnect the leads of the power supply cord from the noise filter, referring to the Figure C-4(a).
4. Release the moulding cord stopper of the power supply cord from the square hole of the oven cavity back plate, referring to the Figure C-4(b).
5. Now, the power supply cord is free.

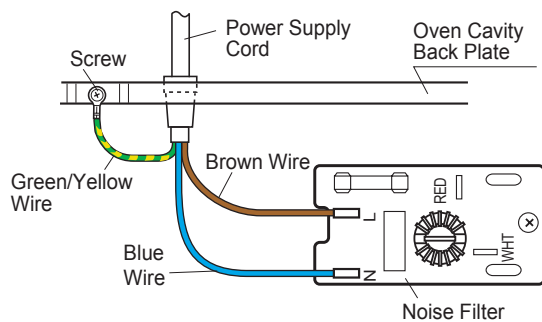

Figure C-4 (a) Replacement of Power Supply Cord

Re-install

1. Insert the moulding cord stopper of power supply cord into the square hole of the power angle, referring to the Figure C-4(b).
2. Install the earth wire lead of power supply cord to the back plate with one (1) screw and tight the screw.
3. Connect the brown and blue wire leads of power supply cord to the noise filter correctly, referring to the Pictorial Diagram.

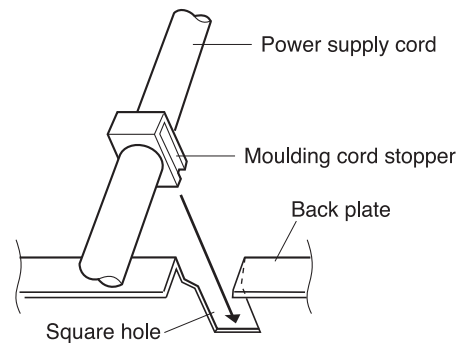

Figure C-4(b). Power Supply Cord Replacement

CONVECTION MOTOR AND CONVECTION HEATING ELEMENT REMOVAL

CONVECTION HEATING ELEMENT REMOVAL

1. CARRY OUT 3D CHECKS.
Now, the outer case cabinet and the air duct should have been removed.
2. Remove the four (4) screws holding the convection heating element.
3. Disconnect the wire lead from the terminals of the convection heating element.
4. Remove the convection heating element from the top of the inner cavity.
5. Now, the convection heating element is free.

CONVECTION MOTOR REMOVAL

6. Remove the three (3) screws holding the convection fan motor bracket.
7. Take out the convection fan motor assembly.
8. Remove the two (2) screws holding the convection fan motor.
9. Now, the convection motor is free.

COMPONENT REPLACEMENT AND ADJUSTMENT PROCEDURE

MONITORED LATCH SWITCH, LATCH SWITCH A AND LATCH SWITCH B REMOVAL

1. CARRY OUT 3D CHECKS.
2. Remove the control panel assembly referring to "CONTROL PANEL ASSEMBLY REMOVAL".
3. Disconnect the leads from all switches.
4. Remove the two (2) screws holding the latch hook to the oven cavity.
5. Remove the latch hook.
6. Remove the switch(es) from the latch hook by pushing the retaining tab backwards slightly and turning the switch(es) on the post.
7. Now the switch(es) is free

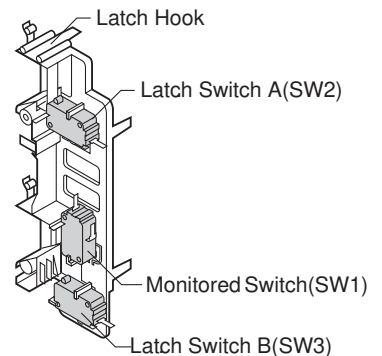

Figure C-5. Switches

MONITORED LATCH SWITCH, LATCH SWITCH A AND LATCH SWITCH B ADJUSTMENT

If the monitored latch switch, latch switch A and latch switch B do not operate properly due to a mis-adjustment, the following adjustment should be made.

1. CARRY OUT 3D CHECKS.
2. Loosen the two (2) screws holding the latch hook to the oven cavity front flange.
3. With the door closed, adjust the latch hook by moving it back and forward or up and down. In and out play of the door allowed by the latch hook should be less than 0.5 mm. The horizontal position of the latch hook should be adjusted so that the plunger of the monitored switch is pressed when the door closed. The vertical position of the latch hook should be adjusted so that the latch switch A and latch switch B are activated with the door closed.
4. Secure the screws with washers firmly.
5. Check the operation of all switches. If each switch has not activated with the door closed, loosen screw and adjust the latch hook position.

Then check the lower position, pushing and pulling lower portion of the door toward the oven face. Both results (play of the door) should be less than 0.5mm.

2. The contacts (COM-NO) of the latch switch B and the monitored latch switch open within 1.8mm gap between right side of cavity face plate and door when door is opened.
3. When the door is closed, the contacts (COM-NO) of the latch switch B and the latch switch A close.
4. When the door is closed the contacts (COM-NC) of the monitored latch switch open. And the contacts (COM-NO) of their switches close.
5. Re-install outer case and check for microwave leakage around the door with an approved microwave survey meter. (Refer to Microwave Measurement Procedure.)

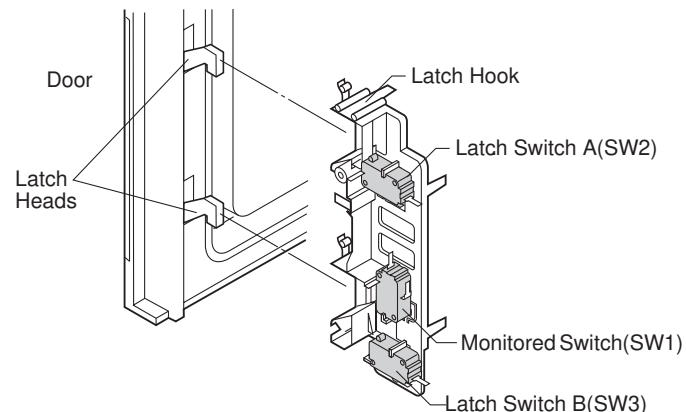

Figure C-6 Latch Switches Adjustment

After adjustment, make sure of following:

1. In and out play of door remains less than 0.5 mm when latched position. First check the latch hook position, pushing and pulling upper portion of the door toward the oven face.

COMPONENT REPLACEMENT AND ADJUSTMENT PROCEDURE

DOOR REPLACEMENT

REMOVAL

1. Disconnect the oven from the power supply.
2. Push the door slightly.
3. Insert an putty knife (thickness of about 0.5mm) into the gap between the choke cover and door frame as shown in Figure C-7 to free engaging parts.
4. Pry the chock cover be inserting a putty knife as shown in Figure C-7.
5. Release chock cover from door panel.
6. Now choke cover is free.
NOTE:WHEN CARRY OUT ANY REPAIR OF THE DOOR, DO NOT BEND OR WARP THE SLIT CHOKE (TABS ON DOOR PANEL ASSEMBLY) TO PREVENT MICROWAVE LEAKAGE.

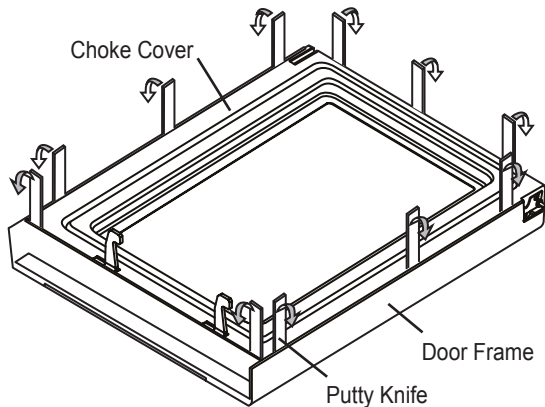

Figure C-7. Door Disassembly

7. Remove two(2) pins of door panel from two(2) holes of upper and lower oven hinges by lifting up.
8. Now, door panel with door frame is free from oven cavity.
9. Release door panel from ten(10) tabs of door frame and remove the door frame by sliding the door panel downward.
10. Now, door panel with sealer film is free.
11. Tear sealer film from door panel.
12. Now, door panel is free.
13. Slide latch head upward and remove it from door frame with releasing latch spring from door frame and latch head.
14. Now, latch head and latch spring are free.
15. Remove the door glass from the door frame by sliding the door glass rightwards.
16. Now, door glass is free.

RE-INSTALL

1. Insert door glass into the door frame by sliding leftwards.
2. Re-install latch spring to the head. Re-install latch spring to the door frame. Re-install latch head to the door frame.
3. Re-install door panel to door frame by fitting ten(10) tabs of door frame to ten(10) holes of door panel.
4. Put sealer film on door panel. Refer to "Sealer film" about how to handle new one.
5. Re-install choke cover to door panel by clipping into position.
6. Locate door panel hinge pins into cavity hinge location holes.

Note: After any service to the door;

- (A) Make sure that latch switch A, latch switch B and monitored switch are operating properly. (Refer to chapter "Test Procedures").
- (B) An approved microwave survey meter should be used to assure compliance with proper microwave radiation emission limitation standards.

After any service, make sure of the following :

1. Door latch heads smoothly catch latch hook through latch holes and that latch head goes through centre of latch hole.
2. Deviation of door alignment from horizontal line of cavity face plate is to be less than 1.0mm.
3. Door is positioned with its face pressed toward cavity face plate.
4. Check for microwave leakage around door with an approved microwave survey meter. (Refer to Microwave Measurement Procedure.)

Note: The door on a microwave oven is designed to act as an electronic seal preventing the leakage of microwave energy from oven cavity during cook cycle. This function does not require that door be air-tight, moisture (condensation)-tight or light-tight. Therefore, occasional appearance of moisture, light or sensing of gentle warm air movement around oven door is not abnormal and do not of themselves, indicate a leakage of microwave energy from oven cavity.

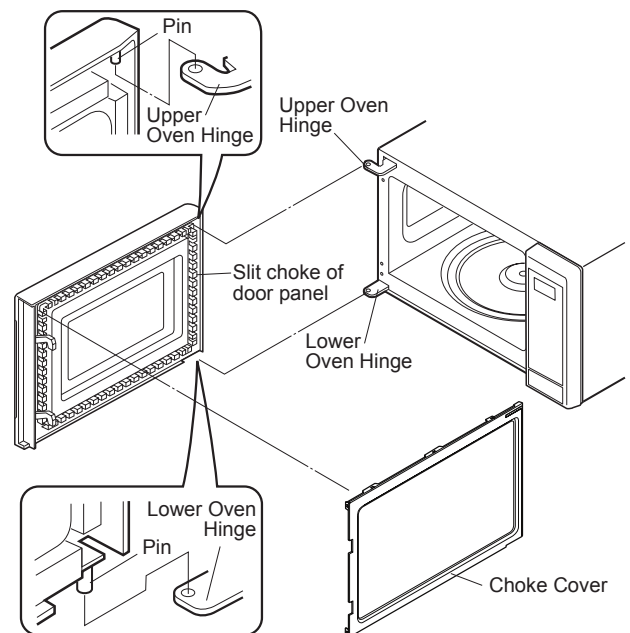

Figure C-8. Door Replacement

SEALER FILM

1. Put the adhesive tape on the backing film of the sealer film as shown in Fig. C-8.
2. Tear the backing film by pulling the adhesive tape.
3. Put the pasted side of the sealer film on the door panel.

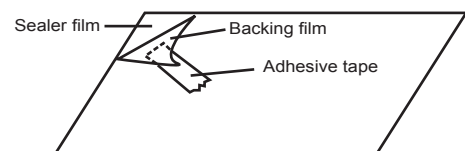

Figure C-9. Sealer film

MICROWAVE MEASUREMENT

After adjustment of door latch switches, monitor switch and door are completed individually or collectively, the following leakage test must be performed with a survey instrument and it must be confirmed that the result meets the requirements of the performance standard for microwave oven.

REQUIREMENT

The safety switch must prevent microwave radiation emission in excess of $5\text{mW}/\text{cm}^2$ at any point 5cm or more from external surface of the oven.

PREPARATION FOR TESTING:

Before beginning the actual test for leakage, proceed as follows;

1. Make sure that the test instrument is operating normally as specified in its instruction booklet.

Important:

Survey instruments that comply with the requirement for instrumentations as prescribed by the performance standard for microwave ovens must be used for testing.

Recommended instruments are:

NARDA 8100

NARDA 8200

HOLADAY HI 1500

SIMPSON 380 m

2. Place the oven tray into the oven cavity.
3. Place the load of $275 \pm 15\text{ml}$ of water initially at $20 \pm 5^\circ\text{C}$ in the centre of the oven tray. The water container should be a low form of 600 ml beaker with inside diameter of approx. 8.5cm and made of an electrically non-conductive material such as glass or plastic. The placing of this standard load in the oven is important not only to protect the oven, but also to insure that any leakage is measured accurately.
4. Close the door and turn the oven ON with the timer set for several minutes. If the water begins to boil before the survey is completed, replace it with 275ml of cool water.
5. Move the probe slowly (not faster than 2.5cm/sec.) along the gap.
6. The microwave radiation emission should be measured at any point of 5cm or more from the external surface of the oven.

