

DISHWASHER SERVICE MANUAL



T SERIES



CONTENT

1. BARCODE STICKER CODE EXPLANATION	3
2. ELECTRICAL COMPONENTS AND MEASUREMENTS	4
3. INTERFACE AND HARDWARE	15
4. WASHING PROGRAMS	15
5. WASHING SPECIFICATION AND PROGRAMS.....	16
6. OPTION.....	24
6.1 Option & models.....	24
6.2 Compatibility between option	24
6.3 Compatibility between option & programs.....	25
6.4 Option definition	25
6.5 Half load	25
6.6 Direct & triple wash	26
6.7 Delay start option	26
6.8 Extra fast / silent option	28
6.9 Tablet	29
6.10 Child lock	30
6.11 Buzzer voice definition	32
6.12 Inner light option	32
6.13 IONIZER	34
7. REGENERATION CYCLE.....	34
8. Water hardness set.....	36
9. RINSE AID SET.....	37
10. SERVICE TEST.....	38
11. FAILURE ROUTINES.....	43
12. DESCRIPTION OF THE VALUES.....	43
13. FAILURE CODES.....	53
14. END TEST PROGRAM	53
15. MEASUREMENT THE WATER HARDNESS	56
16. FAILURE CODES (Possible Problems)	56
17. REPAIR TECHNIQUES COMPONENTS AND RESISTANCE VALUES	60
18. DISASSEMBLY.....	61

1. BARCODE STICKER CODE EXPLANATION



04	668316	00205458	0001
----	--------	----------	------

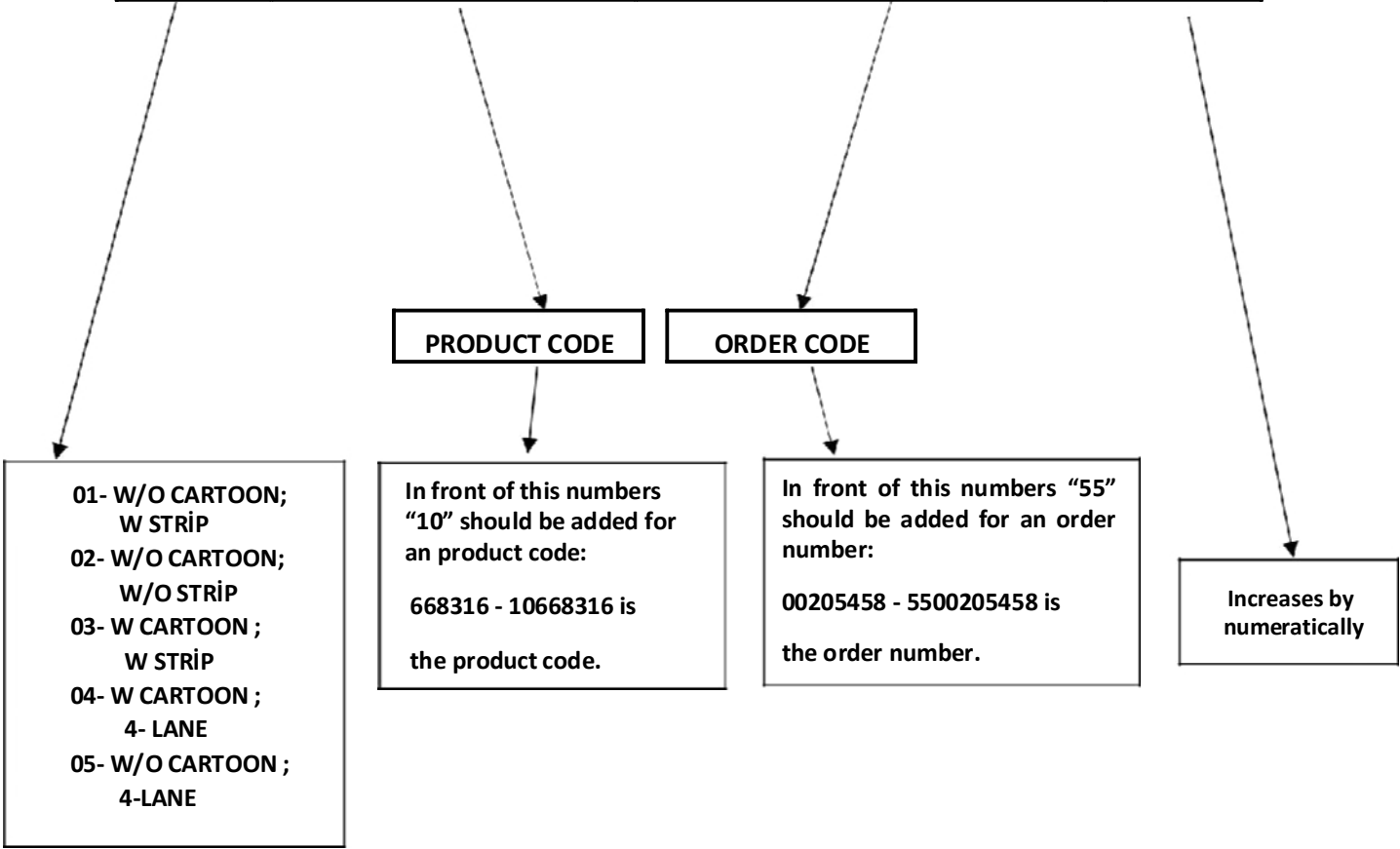

TOOLS FOR DISASSEMBLE



Phillips screwdriver

- *All kinds of star-head screws,
- *in the phillips screws of the internal components,



Plier

- *It is used to bend all kinds of sheet metal ends.



Multimeter

- *Resistance values of all kinds of internal components,
- *Electronic card resistors,
- *It is used to measure the resistance of display cards.



Flat Screwdriver

It is used to remove all kinds of aesthetic parts (side panels, front panels and external aesthetic parts of the machine).



Side Cutter

It is used to cut cables of internal components or any hard part.



Chargeable Drill

It is the most important tool used to remove and install all kinds of screws in the machine.

2.ELECTRICAL COMPONENTS AND MEASUREMENTS

2.1 ON / OFF SWITCH

It can't be measured from the electrical card.

	C	T	
DOOR SWITCH	CN2.9 - CN2.20 Ω	KN2.8 - KN2.10 0 Ω	Door is close

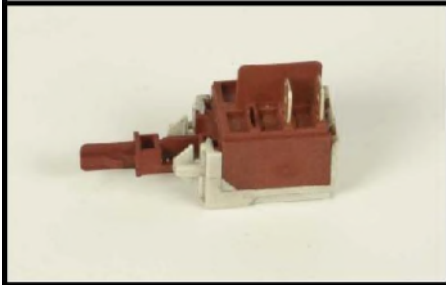

2.2 DOOR LOCK

It is a mechanical lock/release system that is closing the door, supplying the connection of electrical parts in the machine and cutting off the connection.

From the electrical card:

	C	T	
DOOR SWITCH	CN2.9 - CN2.20 Ω	KN2.8 - KN2.10 0 Ω	Door is close

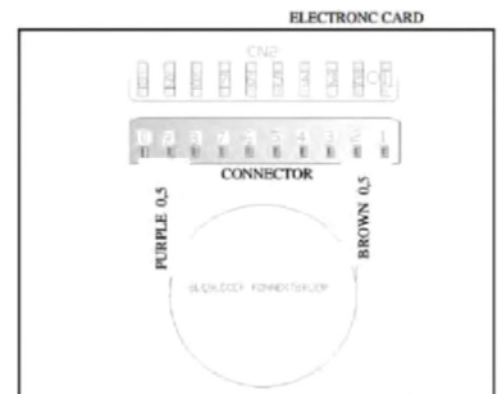
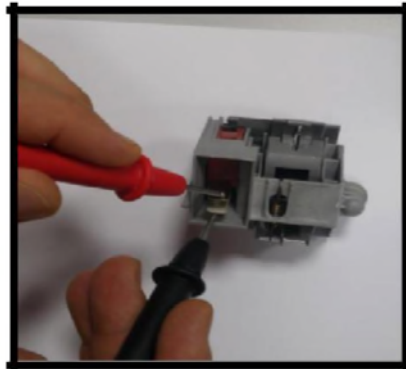
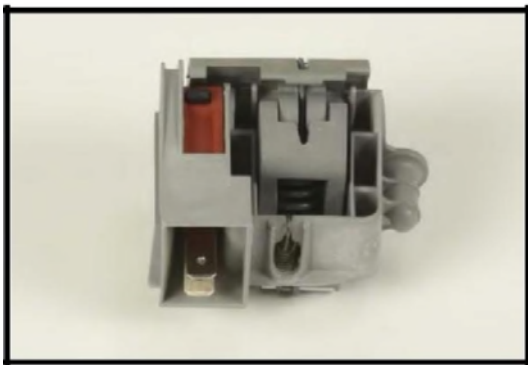

2.3 CIRCULATION PUMP

Single direction, single phase, asynchronous and two pole. It turns opposite clock direction. It is assembled to the basement with rubber hangers.

From the electrical card:

You can only measure the primary winding value from the electrical card. Resistance value of the primary winding must be;

	C		T		
CIRCULATION PUMP	CN2.3 - CN2.9		KN2.3 - KN 2.8		Primary winding Secondary winding (from the component)

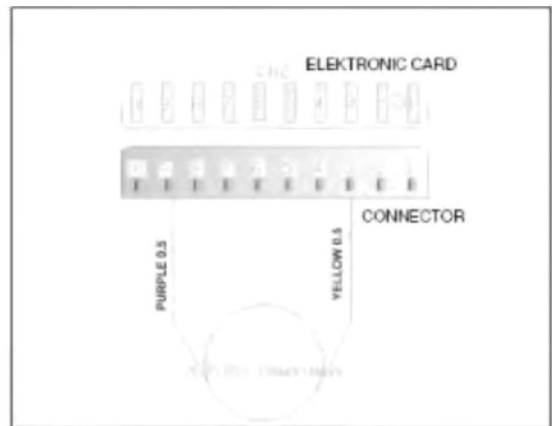

Above sketch show the connectors of the washing pump on the electrical card. Probes of the tester should be applied on to the related connectors.

From the component:



A)

B)

A) Measurement of the primary windings of the washing pump.(118.2-135.9 Ω)

B) Measurement of the secondary windings of the washing pump (white cable – blue cable)(117.9-135.6 Ω)

Probes of the tester should be applied on to the related connectors as shown on the pictures.

2.4 FLOATER

From the electrical card:

	C		T		
FLOATER (MICROSWITCH)	CN2.1 - CN 2.5	0 Ω	KN2.5 - KN 2.10	0 Ω	Microswitch is inactive (no water) microswitch is active (there is water)
	CN2.1 - CN 2.4	∞Ω	KN2.4 - KN 2.5	∞Ω	

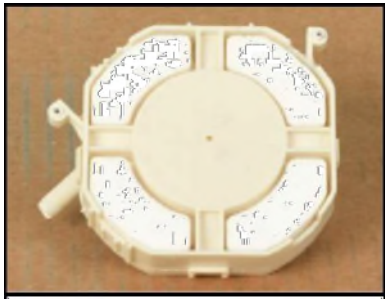

Position 1: You can check the floater by controlling the specified value intervals.

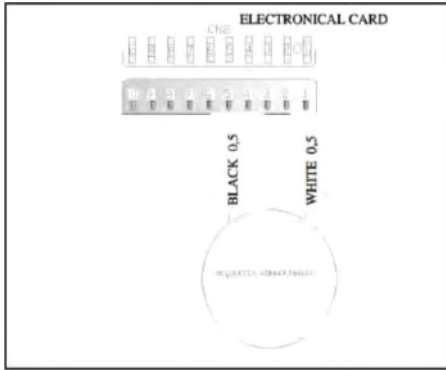

Position 2: If failure code is occurred related with the floater within control the above values: You can figure out whether leakage occurs or not.

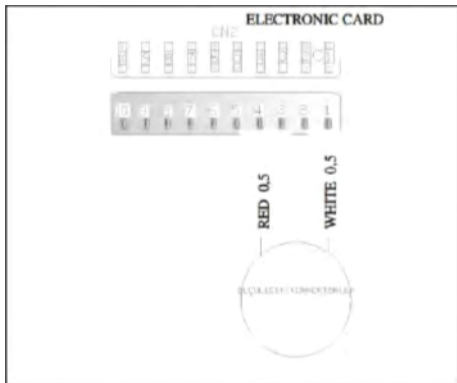

2.5 CAPACITOR

Capacitor is permanently connected to the circulation pump coils.



2.6 DRAIN PUMP

From the electrical Card:

	C		T	
DRAIN PUMP / HANYU	CN2.2 - CN2.4	220 Ω % ±10	KN2.4 - KN2.10	220 Ω % ±10
DRAIN PUMP / LEILI	CN2.2 - CN2.4	141 Ω % ±10	KN2.4 - KN2.10	141 Ω % ±10

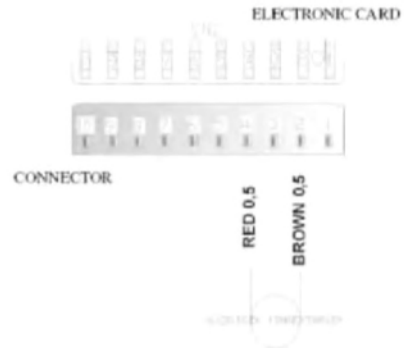

Above sketch show the connectors of the drain pump on the electrical card. Probes of the tester should be applied on to the related connectors.

From the component:



Probes of the tester should be applied on the related connectors as shown on the pictures.

2.7 HEATER

It can' be measured from the electrical card.

From the component:



2.8 NTC

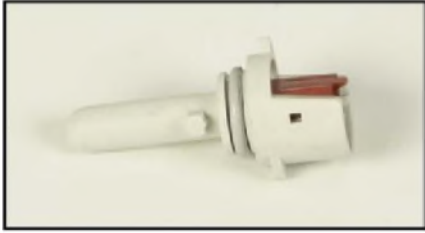

+25 °C	-	47.200	±	850	Ω
+30 °C	-	37.500	±	675	Ω
+40 °C	-	24.900	±	349	Ω
+50 °C	-	17.000	±	170	Ω
+60 °C	-	11.700	±	117	Ω
+70 °C	-	8.280	±	108	Ω
+80 °C	-	5.945	±	101	Ω

2.9 PRESSURE SWITCH

From the electrical card:

	C		T		
PRESSURE SWITCH	CN2.10 - CN2.2	0 Ω ∞Ω	KN2.9 - KN2.10	0 Ω ∞Ω	Full fill water No water

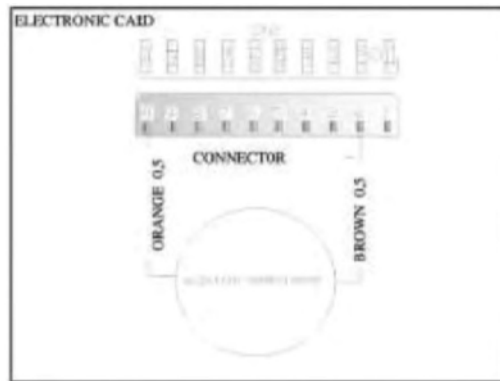
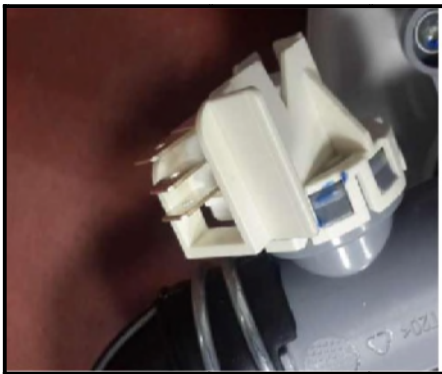

From the component:



2.10 DIVERTER

From the electrical Card:

	C	T
DIVERTER	CN 6.1 - CN 2.9 $10500 \pm \%7 \Omega$	KN 6.1 - KN 2.8 $10500 \pm \%7 \Omega$

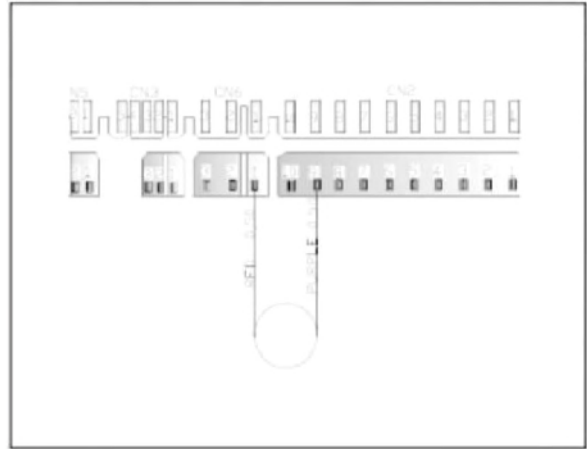
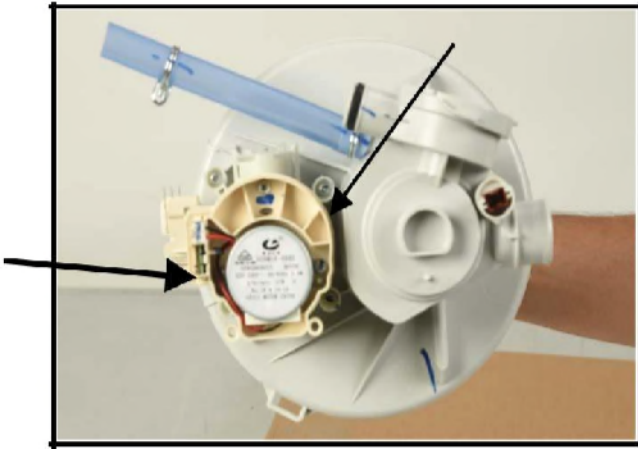

Sketch above show the connectors of the diverter on the electrical card. Probes of the tester should be applied on to the related connectors.

From the component:



Probes of the tester should be applied on to the related connectors as shown on the pictures.

2.11 WATER INLET VALVE

Single inlet and single outlet standard single coil selenoid valve.

From the electrical card:

	C	T
WATER INLET VALVE	CN2.6 - CN2.9 $4200 \Omega \pm \%10 (20^\circ\text{C})$	KN2.6 - KN2.8 $4200 \Omega \pm \%10 (20^\circ\text{C})$

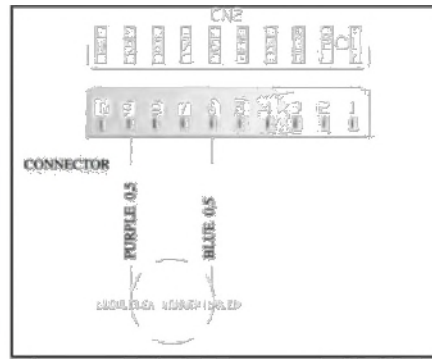

Above sketch show the connectors of the water inlet valve on the electrical card. Probes of the tester should be applied on to the related connectors.

From the component:



Probes of the tester should be applied on to the related connectors as shown on the pictures.

2.12 REGENERATION VALVE

From the electrical card:

	C	T
REGENERATION VALVE	CN2.2 - CN2.7 $3560 \Omega \pm \%10(25^\circ\text{C})$	KN2.2 - KN2.10 $3560 \Omega \pm \%10(25^\circ\text{C})$

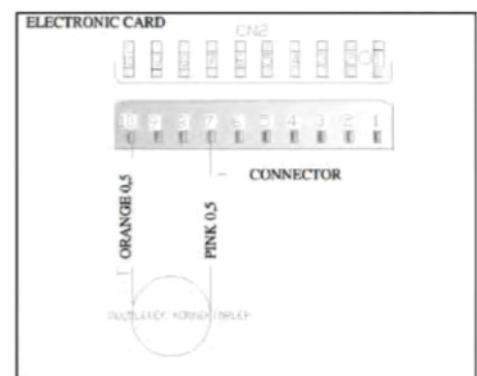
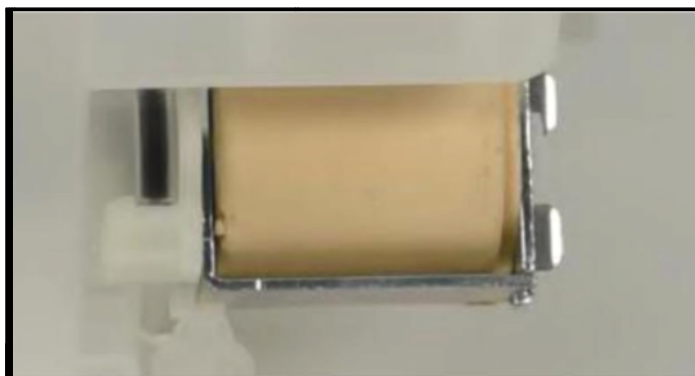

Above sketch show the connectors of the regeneration valve on the electrical card. Probes of the tester should be applied on to the related connectors.

From the component:



2.13 PARASITE FILTER

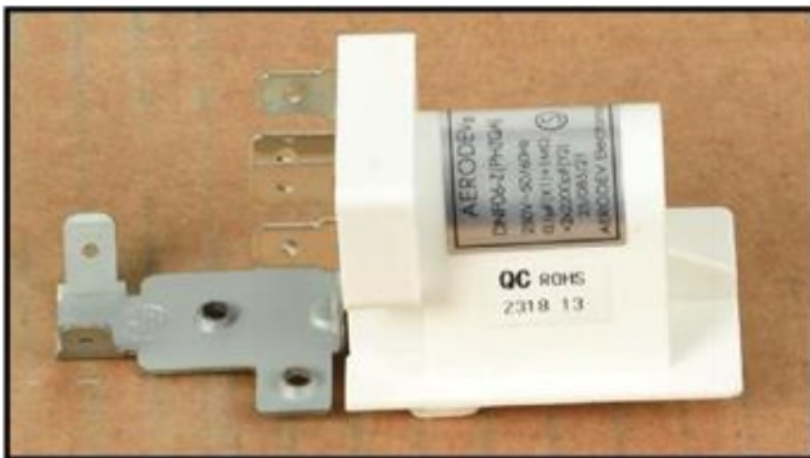

2.14 TURBO FAN MOTOR

From the electrical card:

	C	T
FAN MOTOR	CN 6.2 - CN 2.9	KN 6.2 - KN 2.8

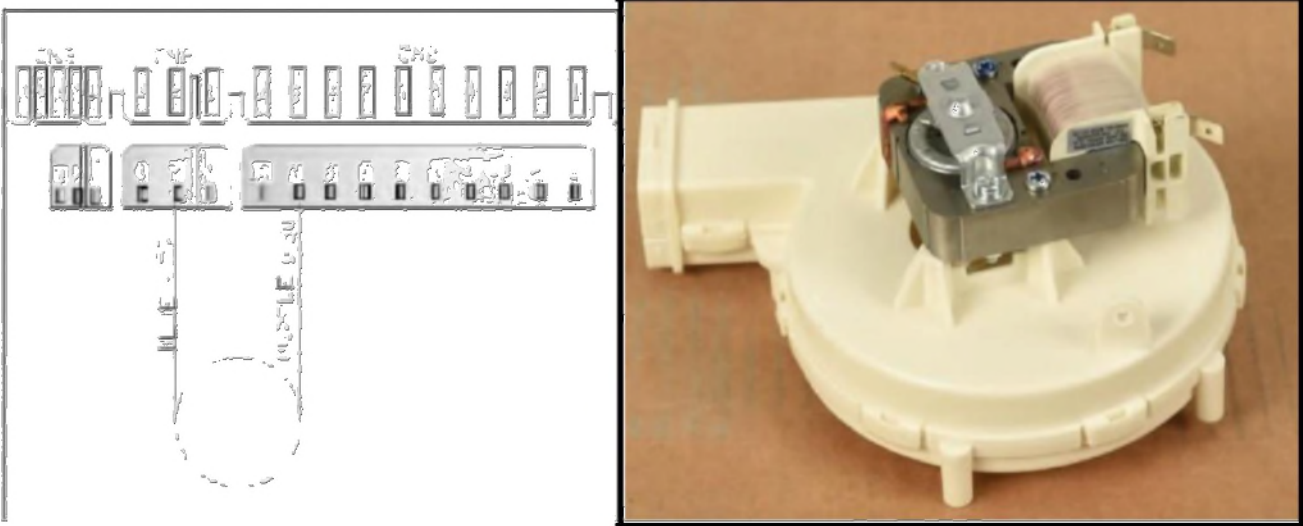

Above sketch shows the connectors of the fan motor on the electrical card.

From the component:



Turbo fan resistance value: $265 \pm \%10 \Omega$ (The resistance of the turbo fan is measured with the resistor switch).

2.15 RINSE AID SENSOR

From the electrical card:

		C	T		
RINSE AID SENSOR	CN 5.3 - CN 5.2	∞Ω NO RINSE AID ∞Ω THERE IS RINSE AID	KN 50.8 - KN 50.9	∞Ω NO RINSE AID ∞Ω THERE IS RINSE AID	RINSE AID OFF RINSE AID ON

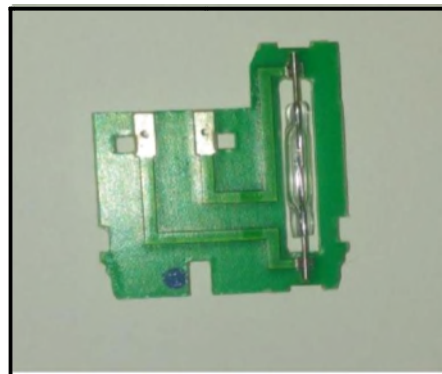
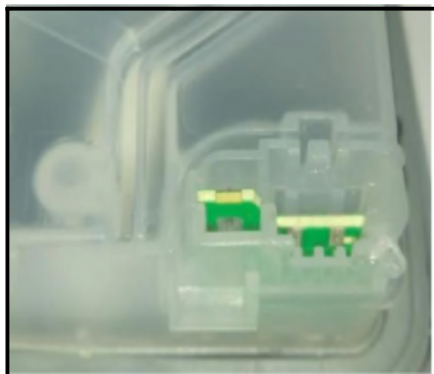

Below sketch shows the connectors of the rinse aid sensor on the electronic card.

From the component:

Probes of the tester should be applied on to the related connectors as shown on the pictures.

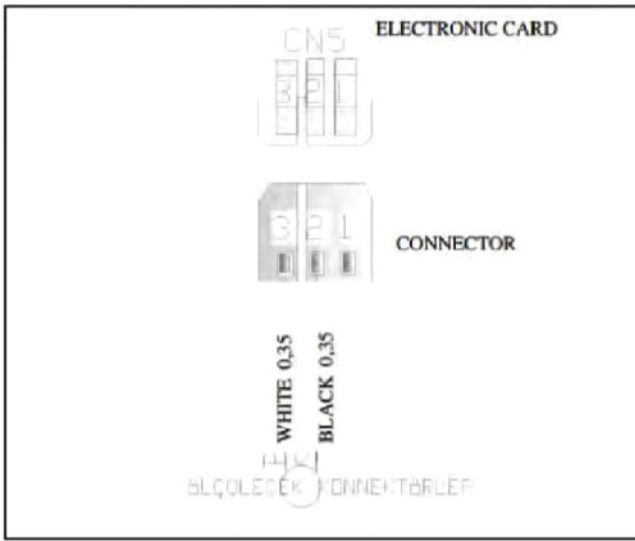

2.16 SALT SENSOR

Salt sensor can also be measured from the water softener when the salt sensor assembled on the water softener.

From the electronic card:

		C		T	
SALT SENSOR	CN5.1 - CN5.2	0 Ω NO SALT ∞Ω THERE IS SALT	KN50.10 - KN 50.11	0 Ω NO SALT ∞Ω THERE IS SALT	Measure just on the electronic

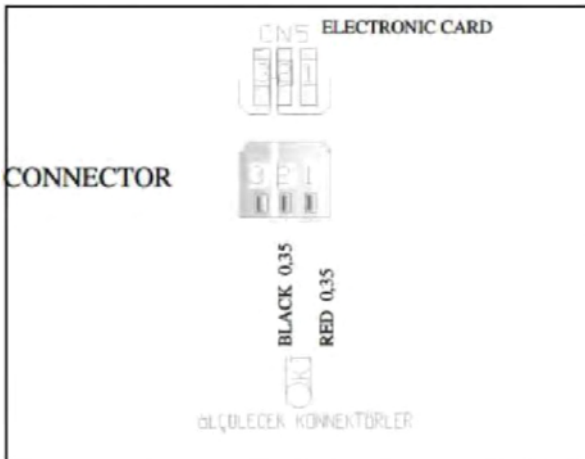

Sketch above show the connectors of the salt sensor on the electronic card. Probes of the tester should be applied on the related connectors.

From the component:



2.17 POWER CORD



2.18 DETERGENT / RINSE AID DISPENSER

It can't be measured from the electrical card:

	C	T
DETERGENT DISPENSER	2300 Ω \pm10% (25 C°)	2300 Ω \pm10% (25 C°)

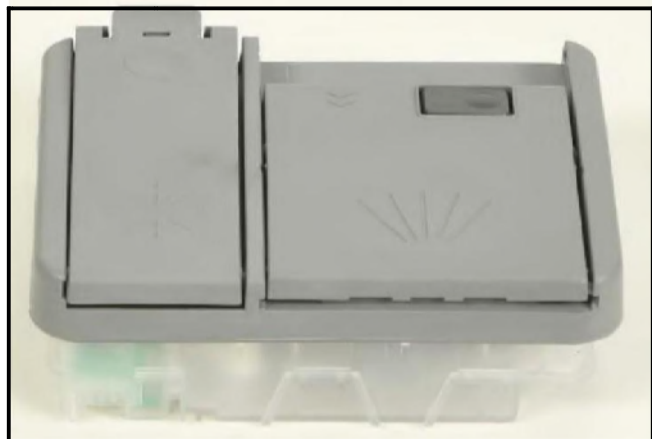

3. INTERFACE AND HARDWARE

3.1 INTERFACE MOD. LED MODULE T33_1

Apart from ON/OFF switch, component interface includes:

- 3 buttons at left side of LED Module;
 - PROGRAM button
 - HALF LOAD button
 - TABLET button
- 4 buttons at right side of LED Module too.
 - DELAY timer button
 - ENERGY SAVE button
 - EXTRA fast/silent button
 - START/PAUSE button

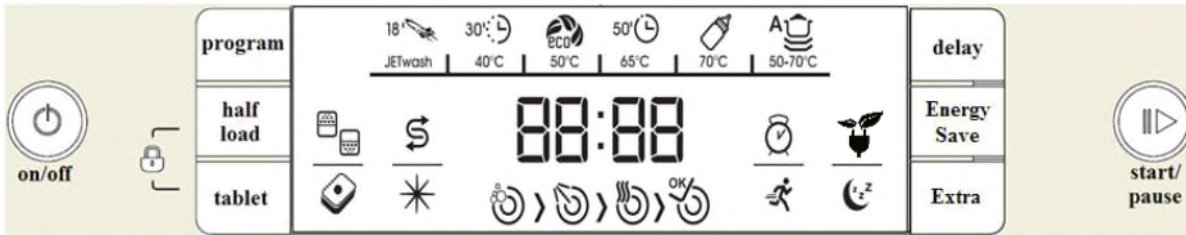

3.2 INTERFACE MOD. LED MODULE T34_1 MODEL.

Apart from ON/OFF switch, component interface includes:

- 3 buttons at left side of LED Module;
 - PROGRAM button
 - HALF LOAD button
 - TABLET button
- 4 buttons at right side of LED Module;
 - DELAY timer button
 - ENERGY SAVE button
 - EXTRA fast/silent button
 - START/PAUSE button

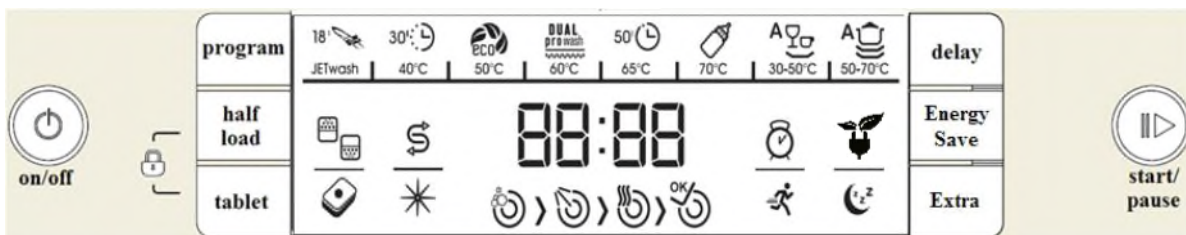

4. WASHING PROGRAMS

WASHING PROGRAM CROSS TABLE

Model	Jetwash '18	Quick 30'	Eco 50°C	Dual Pro Wash 60°C	Super 50'	Hygiene	Auto Delicate 30°-50°C	Auto Intensive 50°-70°C
LED MODULE T33_1	X	X	X	-	X	X	-	X
LED MODULE T34_1	X	X	X	X	X	X	X	X

X = present - = not present

5. WASHING SPECIFICATIONS AND PROGRAMS

5.1 SELECTING AND STARTING AT POWER ON:

Switch-on: When dishwasher is switched on, all leds are shown on the led module. After 1-2 seconds,

- LED Module gives **Voice_1 sound**
- Due to Eco design requirements, each energized of the machine (by pressing ON/OFF)
 - Eco program is fixed as default
 - Energy save option icon must be ON (only valid for Eco)
 - The options that are chosen before will be cancelled.



Selecting of a program: By pressing “program button”, the program icon is changed from left to right, and when it comes at the rightmost, it returns to beginning.

- Press the Program Selection button until the required program is shown on the display. The last selected program icon blinks (1sec. On, 1sec. Off → **this duration will be fixed after checking the working samples**),
- In the meantime, other program icons and last selected option icons are always illuminated.
- The duration of the selected program is visualized in the display.
- LED Module gives **Voice_2 sound**
- Button reaction time must be 200msn maximum.(after pushing P button, program must be changed in 200msn maximum)

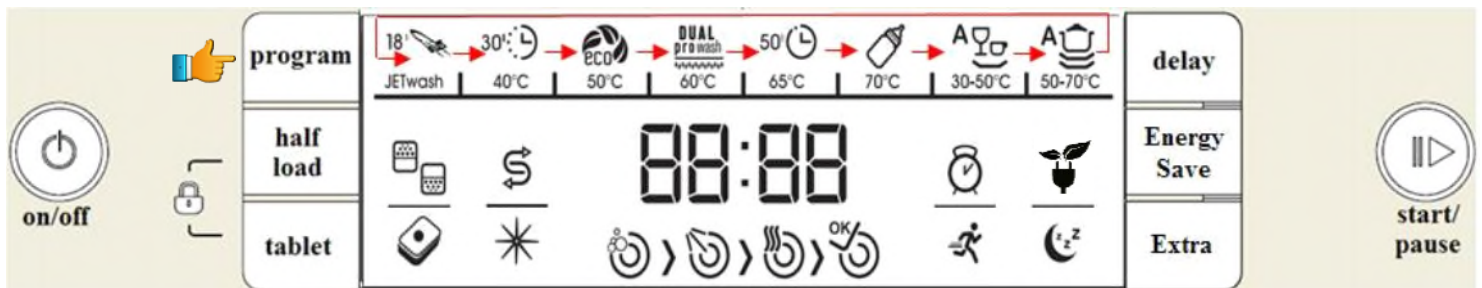

- When selecting a program, if the program matches with non suitable option (but already selected) (ex. Quick 30' Tablet), non suitable option icon disappears. When user continues to change the programs, if the option is compatible with selected program, option icon lights up.

Starting of a program: Program starts by pressing Start/Pause button. When the program starts,

- Selected program icon lights up, other program icons disappear on screen,
- The remaining time of dedicated program is visualized (two dots blinks),
- Wash icon and bar on the right side lights up,
- Selected option icon lights up,
- LED Module gives **Voice_3 sound**.



During wash, LED module shows program indicator icons (wash-rinse-dry-end).

- If cycle on the “wash” step; wash icon and bar on the right side illuminate.



- If cycle on the “rinse” step; rinse icon and bar on the right side illuminate.



- If cycle on the “dry” step; dry icon and bar on the right side illuminate.



- If cycle on the “end” step; end icon illuminates.



Working principle of LED Bar & icons;

- Before the select icon, display do not show anything.

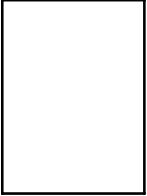

- After the select at least one icon, display show the selected icon and LED bar.

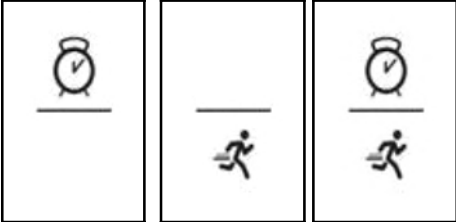

5.2 PAUSING AND CANCELLING THE PROGRAM AT POWER ON:

Pausing of a program: During a program; press Start/Pause button to pause a program.

- Selected program icon blinks and remaining program icons become ON.
- Two dots and four digits blinks,
- “Related program indicator icon” and bar on the right side blinks,
- LED Module gives **Voice_2 sound**.



Cancelling of a program: During a program; press **S/P** button for 3sec. While pressing S/P button (during 3sec.), display shows the countdown from 3 to 1 sec. After 3sec (**Voice_6**);

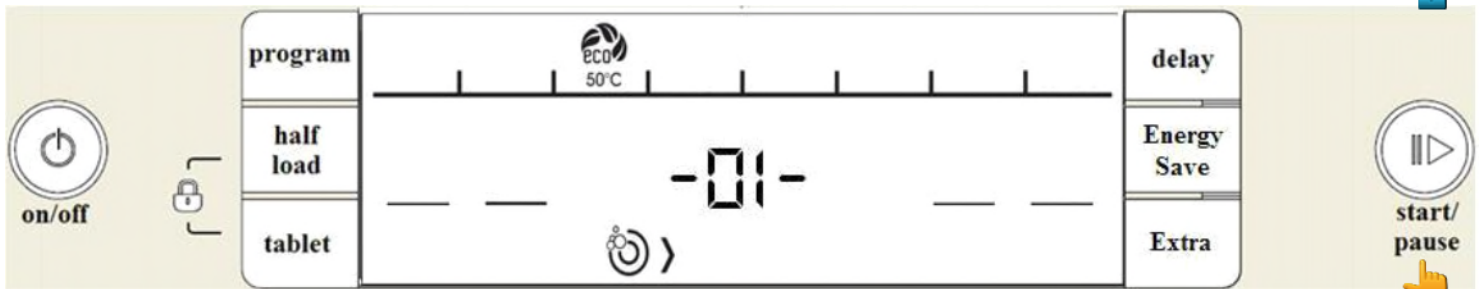

display shows:

- “00:01” at the time zone and draining will be executed.
- “END” icon and two dots blinks,



At the end of the cycle, the “END” icon will be ON and the buzzer will be activated. (Voice_5).

- “00:00” at the time zone,
- “END” icon lights up forever.



5.3 MODIFICATION OF A PROGRAM

If user want to change the program;

- Press the **Start/Pause** button,
- Then press the **Program button** to select a new program. Each press of the “program button”, the program is changed from left to right and when it comes at the right side, it goes back to left side.
- To start the required program, press the **Start/Pause** button (if the new program has a corresponding step, display shows the time of the new program without the passed time).

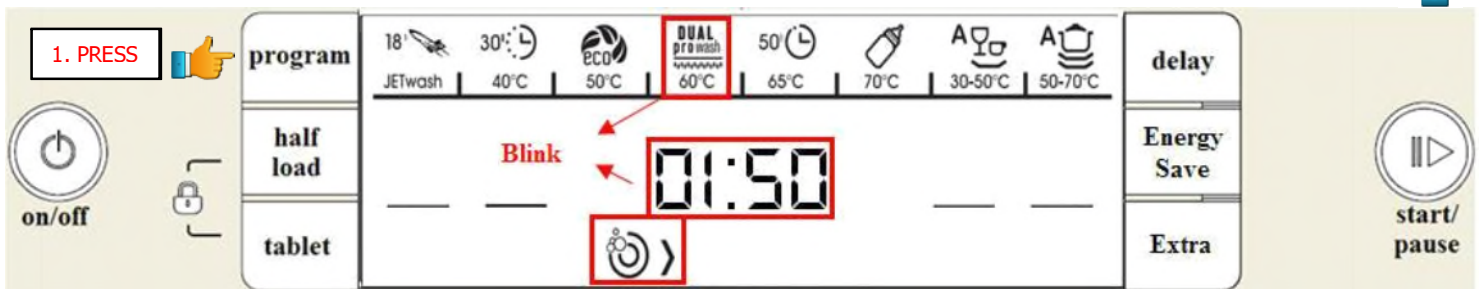
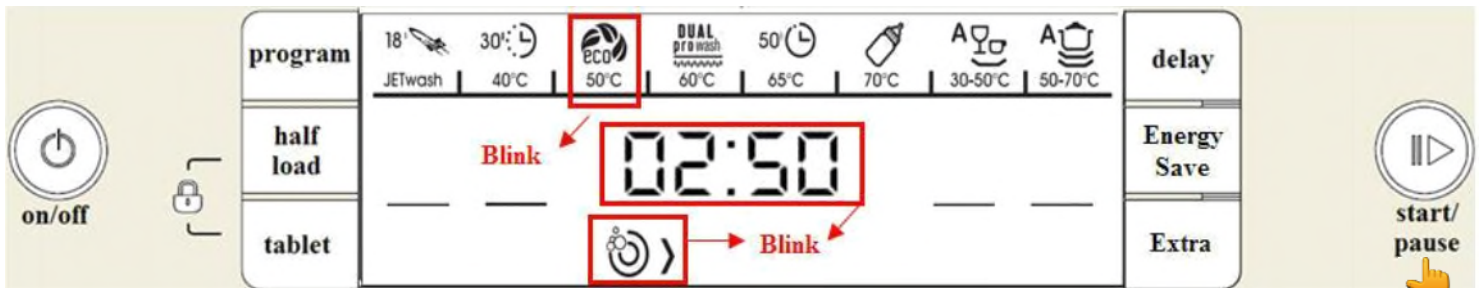
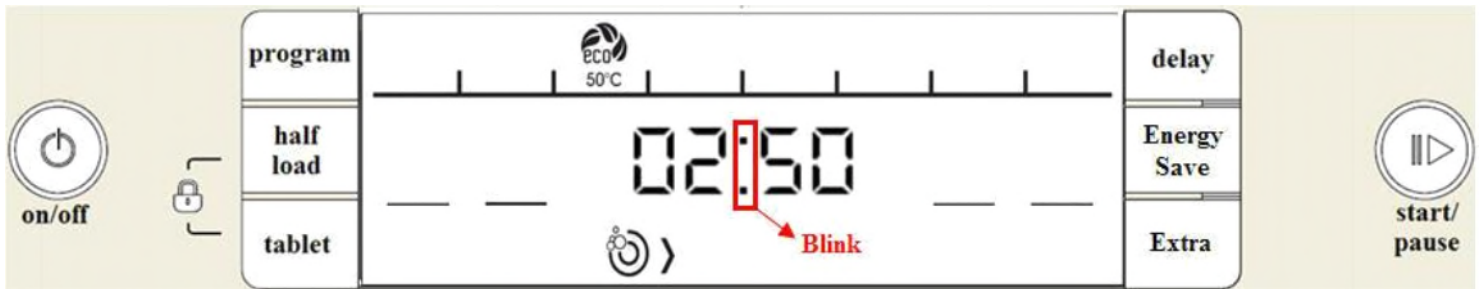

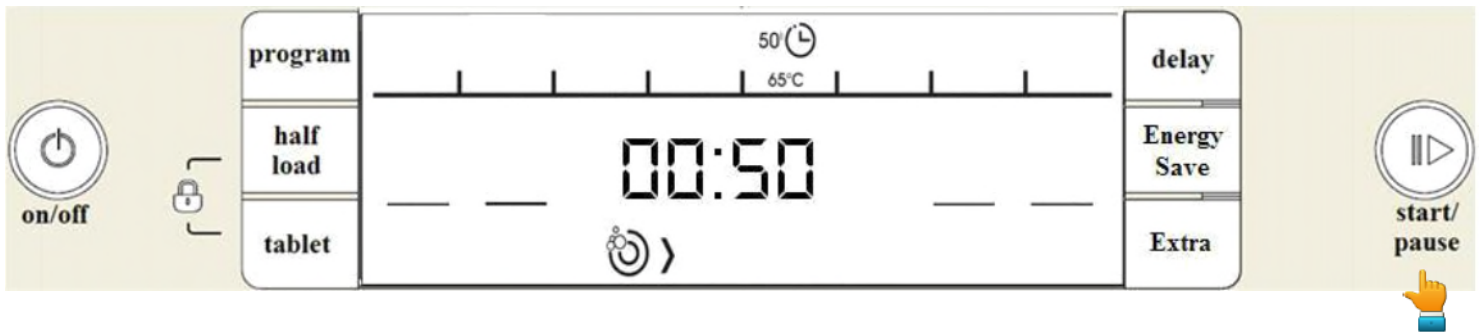

5.4 OPENING AND CLOSING DOOR DURING PROGRAM (NOT IN DRY STEPS):

During the program if the door is opened and re-closed without any modifications at the program button and without the pressure of S/P button, the program continues. Washing program re-starts after 8" if the measured temperature is equal or more than 45°C. Washing program re-starts immediately if the measured temperature is equal or less than 45°C.

Opening door:

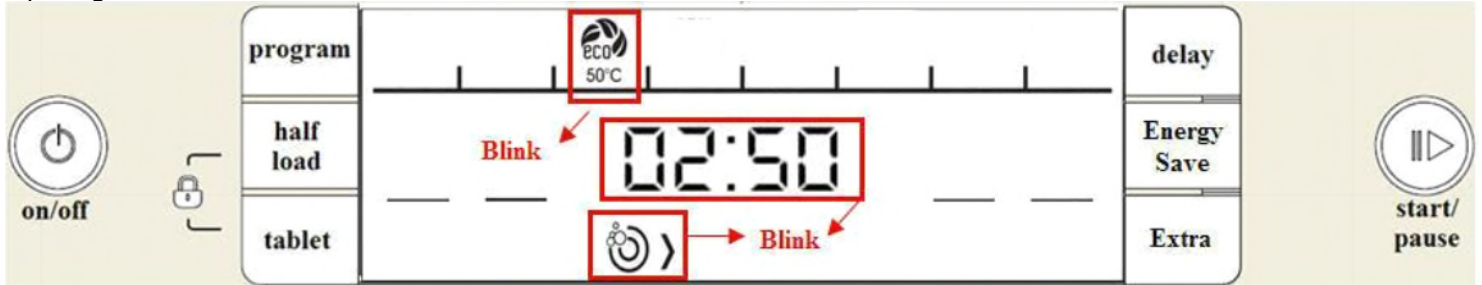

Closing door:



After the door is opened (Note: without S/P button pressed, remaining program icons do not become ON)

5.5 OPENING AND CLOSING DOOR DURING A DRY STEP:

During dry if the door is opened,

- Selected program icon blinks,
- Two dots and four digits blinks,
- "related program indicator icon" and bar on the right side are blinks,
- Then re-closed, the program continues.

Opening door:

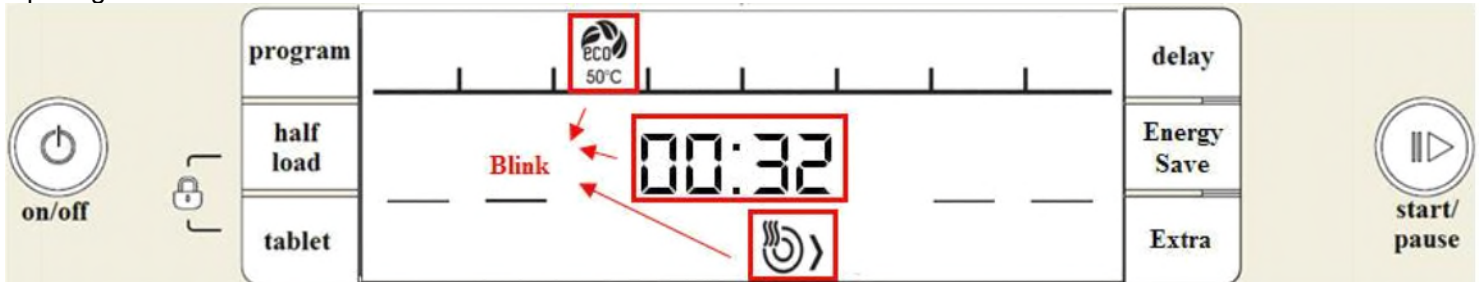

Closing door:



5.6 SELECTING AND STARTING PROGRAM AT DOOR OPENED (DURING WASH):

It is not possible to select programs and options until the machine is paused by the S/P button. If user tries to press any button without pressing S/P button, LED Module gives **Voice_3** sound.

Opening door:

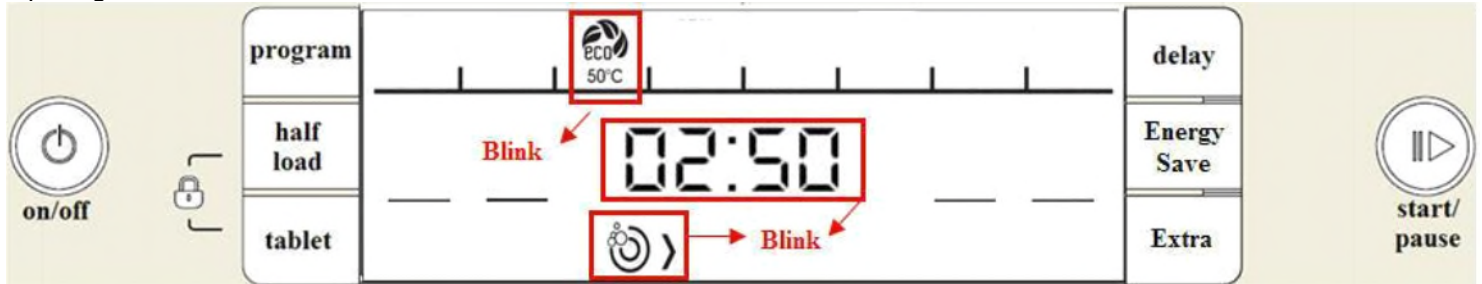

If user press the S/P button, LED Module returns to previous position (possible that selecting program and options)

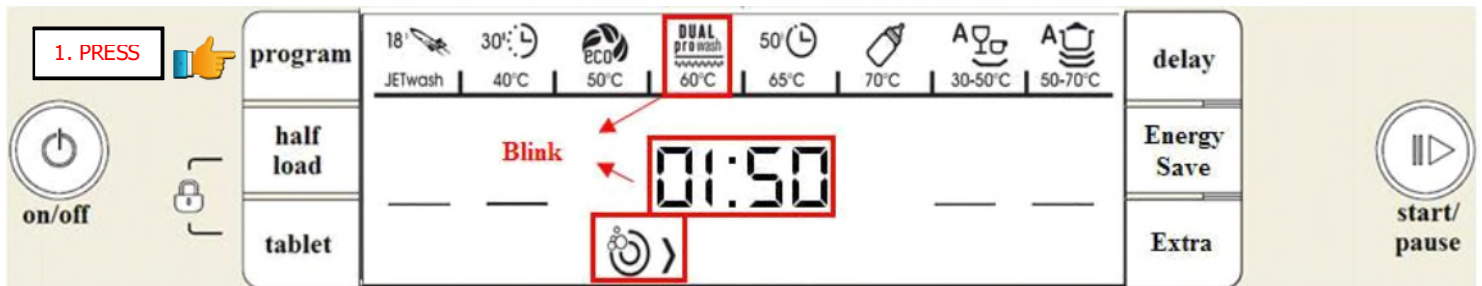

Note: Since the S/P button is pressed to change program while door is opened, after door is closed the S/P button is again needed to be pressed one more time to re-start the program.

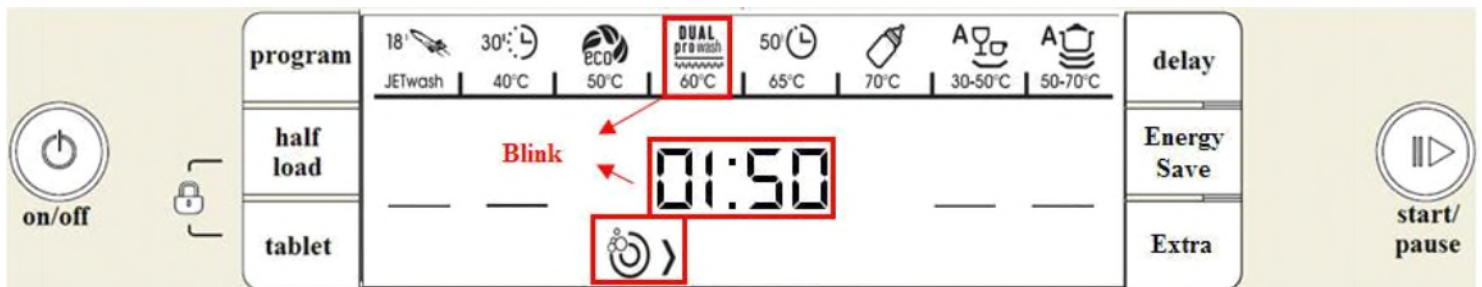

Closing door:



5.7 SELECTING AND STARTING PROGRAM AT DOOR OPENED (BEFORE WASH):

It is possible that selecting program and options when the door is open position, If pressed the “start pause button” at this time;

- Selected program icon blinks (1sec. On, 1sec. Off → this duration will be fixed after checking the working samples),
- Other program icons disappear from display,
- LED Module gives Voice_3 sound.



Opening the door and press Program button:

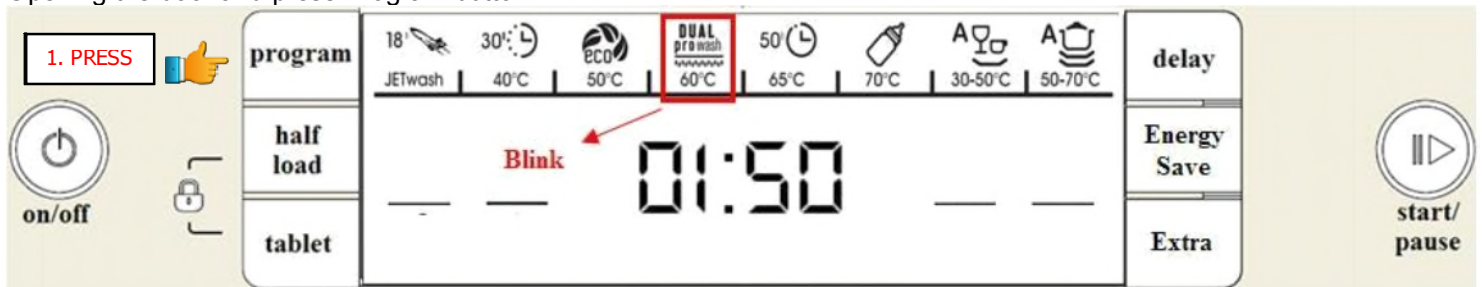

It is not possible that selecting program and options after pressed the S/P button. If user tries to press any button, LED Module gives **Voice_3 sound** at that time. If user press the S/P button again, LED Module return the previous position (possible that selecting program and options)

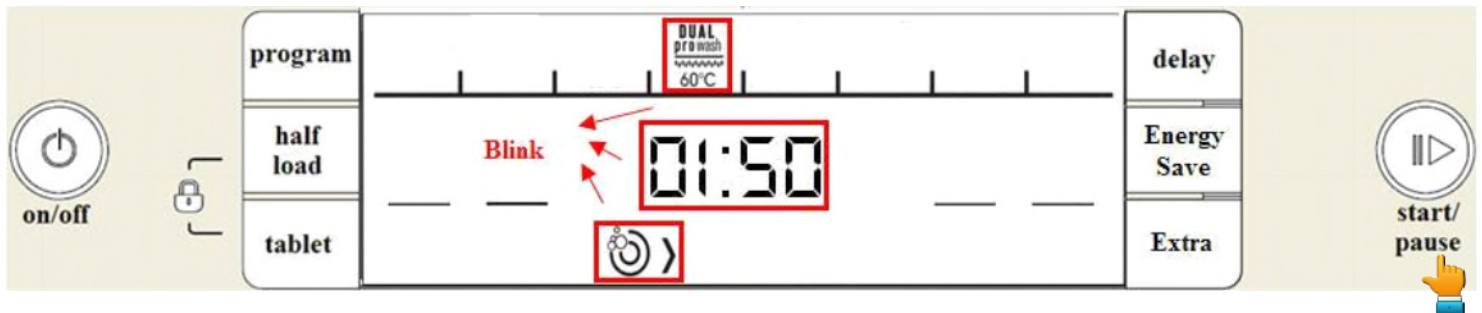

After the door is closed, program starts.



5.8 AT THE END OF PROGRAM, IF THE USER PRESS THE PROGRAM BUTTON OR ANY BUTTON:

At the end of the program;

- Selected program and options icons keep to lighting,
- Remaining time of the program ("00:00") is shown on the screen.
- End icon illuminates.
- "Voice_5" alert is activated to show program is finished.



If user presses any button at the end of program, all buttons fulfil the function and LED module turns to start position.



5.9 POWER FAIL:

If Power fail occurs:

- During a **Delay Start**. At the power on, program consumes the remaining time.
- During a **Drain + Fill** step. At the power on the program continues from remaining.
- During a **Wash** step. At the power on the program consumes the remaining time.
- During a **Heating** step. At the power on the program continues heating up to the desired temperature. The time out for the heating restart to the beginning (water could be cold again).
- During a **Dry** step. **At the power on the program ends.**

It is possible that the power fail occurred when a regeneration cycle is requested. If it occurs:

- During the first two step of a salt regeneration cycle (60" REGVALVE = ON or 60" REGVALVE+DRAIN ON): at the power on washing program will continue.
- After the first two step of a salt regeneration cycle: at the power on the washing program will end and the resin wash will be performed at the beginning of the next washing cycle.

After a Power Fail washing program re-starts without any delay if temp. Is less than 45 °C

After a Power Fail washing program **wait 8"** before re-starts program if temp. Is equal or more than 45 °C .

5.10 OPENING AND CLOSING DOOR OR PRESSING START/PAUSE

- During a **Delay Start**. At closing door or pressing S/P, program consumes the remaining time. The time in progress is saved every 1'.
- During a **Drain + Fill** step. At the closing door or pressing S/P the program continues from the remaining.
- During a **Wash** step. At the closing door or pressing S/P, the program consumes the remaining time. The time in progress is saved every 1'. Washing program re-starts after 8" if the measured temperature is equal or more than 45°C.
- During a **Heating** step. At the closing door or pressing S/P, the program continues heating up to the desired temperature. The time out for the heating restart to the beginning (water could be cold again).
- During dry if the door is opened and re-closed, the program continues.

5.11 MODIFICATION OF A PROGRAM WITHOUT PRESSURING S/P:

- During the program if the user press any button (**without** pressuring of S/P), the program in progress continues and buzzer warning sound is activated to show that this is not a valid command.
- Buzzer sound “voice_4” will be activated to warn the user for invalid command.

5.12 MODIFICATION OF A PROGRAM WITHOUT RESET:

- The program continues with flow but with the parameters (temperature, times) of the new program.
- In heating step: If temperature is over than the new desired temperature, cut off of heating step and go on with the next step with new parameters.
- If temperature is lower than the new desired temperature heat up water to the desired temperature level.
- In washing step: If the washing duration is over than the new program washing duration cut off washing step and go on with next step of new program.
- If the washing duration is lower than the new program washing duration, keep going on to washing step until required washing completes.

6. OPTIONS

6.1 OPTIONS & MODELS

OPTION	LED Module_1 T33_1	LED Module_2 T34_1
Delay Start	X	X
Half Load (3 modes)	X	X
Direct&Triple wash	X	X
Tablet	X	X
Energy Save(A.door)	X	X
Extra Fast/Silent	X	X

NOTE: If the model has both direct and triple wash, it has not half load option.

6.2 COMPATIBILITY BETWEEN OPTIONS

Options	Delay Start	Half Load (3 modes) or Direct&Triple wash	Tablet	Child Lock	Energy save	Extra Fast	Extra Silent
Delay Start		OK	OK	OK	OK	OK	OK
Half Load (3 modes) or Direct&Triple wash	OK		OK	OK	OK	OK	OK
Tablet	OK	OK		OK	OK	OK	OK
Child Lock	OK	OK	OK		OK	OK	OK
Energy Save	OK	OK	OK	OK		OK	OK
Extra Fast	OK	OK	OK	OK	OK		-
Extra Silent	OK	OK	OK	OK	OK	-	

6.3 COMPATIBILITY BETWEEN OPTIONS & PROGRAMS

	OPTIONS	Delay Start	Half Load (3 modes) or Direct&Triple wash	Tablet	Child Lock	Energy Save	Extra Fast	Extra Silent
PROGRAMS								
Jetwash 18'		X	X	-	X	X	-	-
Quick 30'		X	X	X	X	X	-	-
Eco50°C		X	X	X	X	X	X	X
Dual Pro wash		X	X	X	X	X	X	X
Super 50'		X	X	X	X	X	-	-
Hygiene 70 C		X	X	X	X	X	-	-
Auto Delicate 30°/50°C		X	X	X	X	X	-	-
Auto intensive 50-70 C		X	X	X	X	X	-	-

6.4 OPTION DEFINITION

Option	Short description
Delay Start	Program starts with a delay
Half Load(3 modes)	The wash is executed with upper spray, Lower spray or both in half load mode.
Direct&Triple wash	Direct wash is performed with upper and extra upper sprays. Triple wash is performed with lower and extra lower sprays. Both Direct wash + Triple wash is performed with upper, extra upper, lower and extra lower sprays.
Tablet	Change of washing temperature and time
Child Lock	It can be activated by pressing "UP" and "DOWN" buttons at the same time for 3 seconds, Keys are blocked to press.
Energy Save	At the end of the drying process, the dishwasher door automatically opens to allow steam to escape and cool air to circulate.
Extra Fast	Reduces the duration of the washing
Extra Silent	Reduces the sound pressure level of the washing

6.5 HALF LOAD

Half Load option is selectable any time by pressing the regarding option button.

When Half Load button is pressed:

First time: upper spray icon is ON and lower spray icon is OFF. Wash is executed only with upper spray arm.



Second time: upper spray icon is OFF and lower spray icon is ON. Wash is executed only with lower spray arm.



Third time: upper spray icon is ON and lower spray icon is ON.



Fourth time: upper spray icon is OFF and lower spray icon is OFF. Normal wash .



6.6 DIRECT & TRIPLE WASH

Direct & Triple wash can be selected at any time by pressing regarding option button.

When Direct&Triple button is pressed:

First time: Direct wash icon is ON and Triple wash icon is OFF. Wash is executed only with upper and extra upper sprays.

Second time: Direct wash icon is OFF and Triple wash icon is ON. Wash is executed only with lower and extra lower sprays.

Third time: Direct and Triple wash icons are ON. Wash is executed with upper, extra upper, lower and extra lower sprays.

Fourth time: Direct and Triple wash icons are OFF. Normal wash is executed.

6.7 DELAY START OPTION

Delay start option is selected before program start ; firstly dedicated “DELAY button” is being pressed, delay icon is getting activated (blinks) ,display shows ‘ h:01’ at time zone. After that needed time to delay can be chosen “DELAY button”.

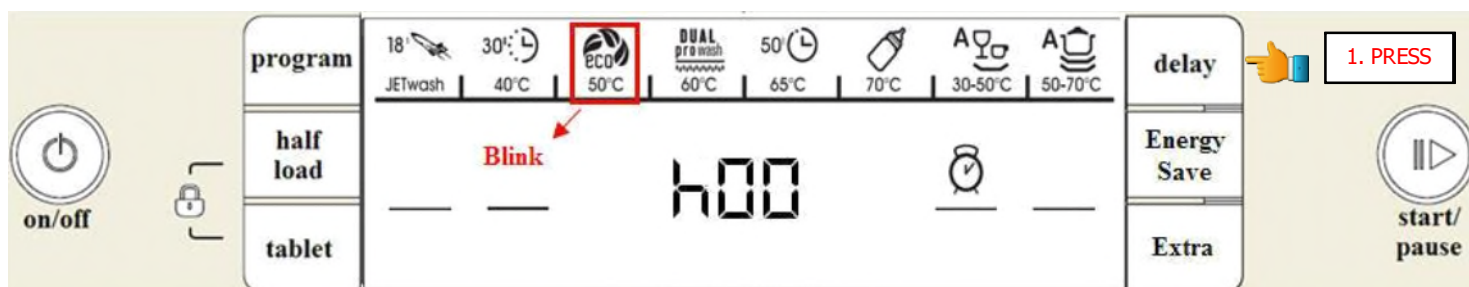

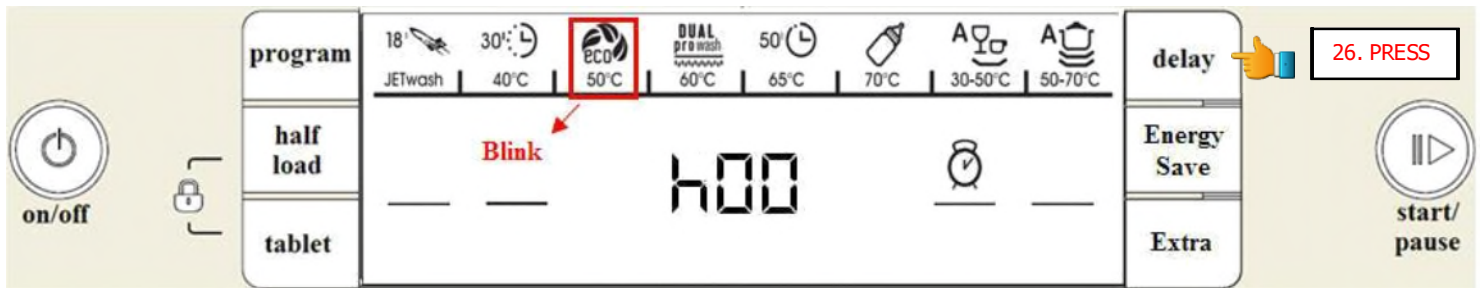
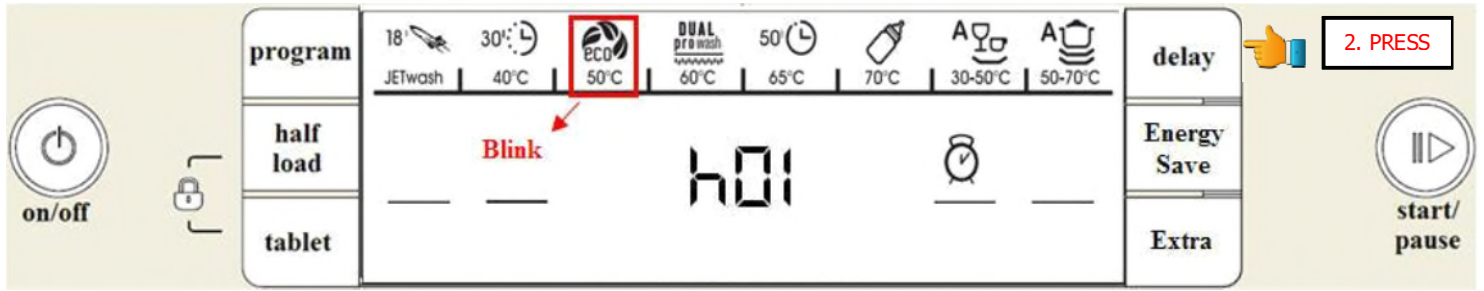

If user change the program after select delay time, display separately shows delay time and program time.
 Note: In the display at every 3secs, the Delay value will be shown. (Ex: 3secs "00:30", 1sec " h:01").

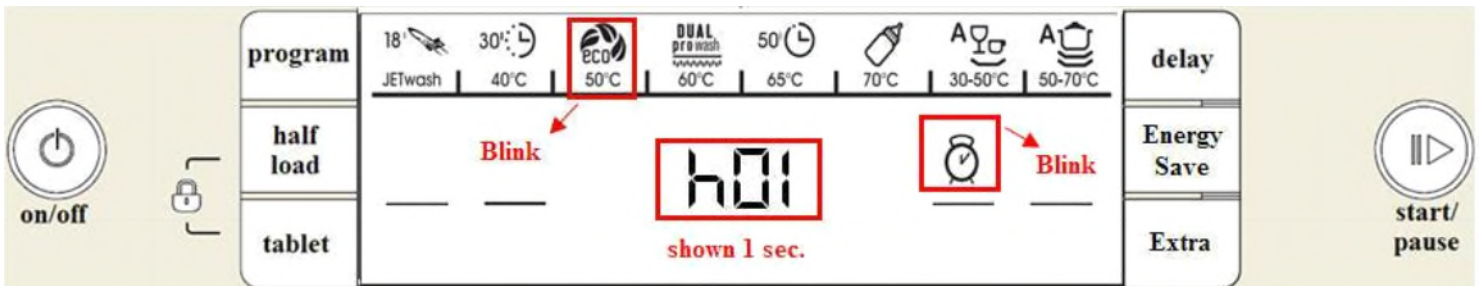

Note: During the program it is not possible to activate the delay option, in this case buzzer sound "voice_4" is activated to show that is not a valid command.

When the delay time and program are chosen, delay time function gets activated by pressing Start/Pause Button, time countdown starts and the value of the chosen shown at time zone side and also delay icon is getting activated with give **Voice_3 alert** (In the display at every 3secs, the Delay value will be shown).
 Ex: 3secs "02:20", 1sec " h:01"

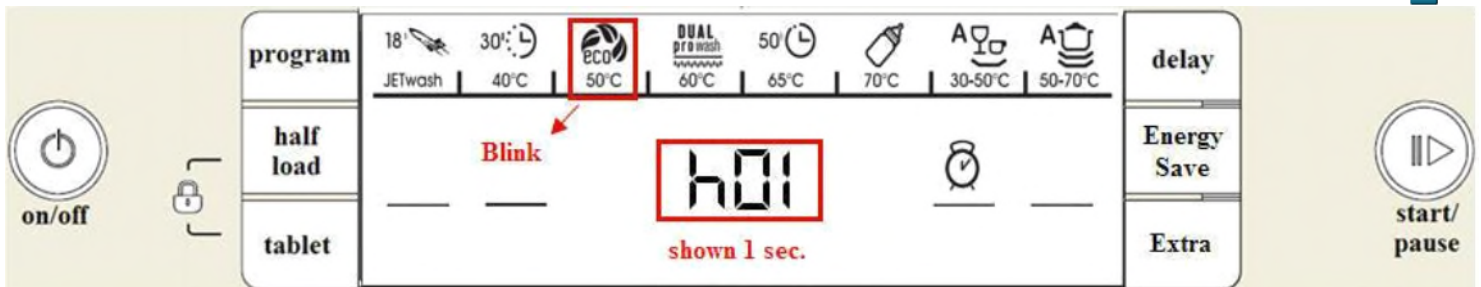
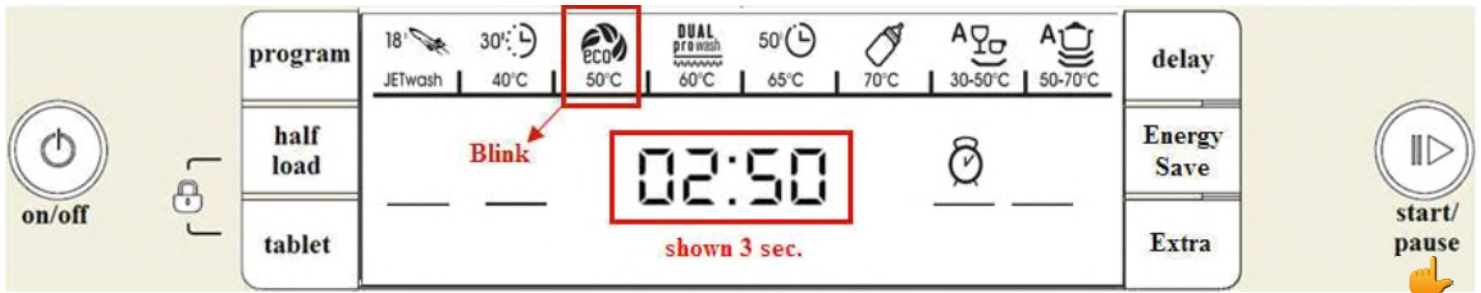

To change this option during a delay time it necessary to press S/P button and put the machine in “pause” mode. Before start program, the delay option selects with pressure of “DELAY button”. The steps of increment are one hour. Then the display shows the remaining delay time with steps of one hour (h:01, h:13, h:24 etc). The maximum value of the delay is 24 hours.

To cancel this option during a delay time it necessary to press S/P button and put the machine in “pause” mode and press the delay button until display shown at the time zone “ h:00”.

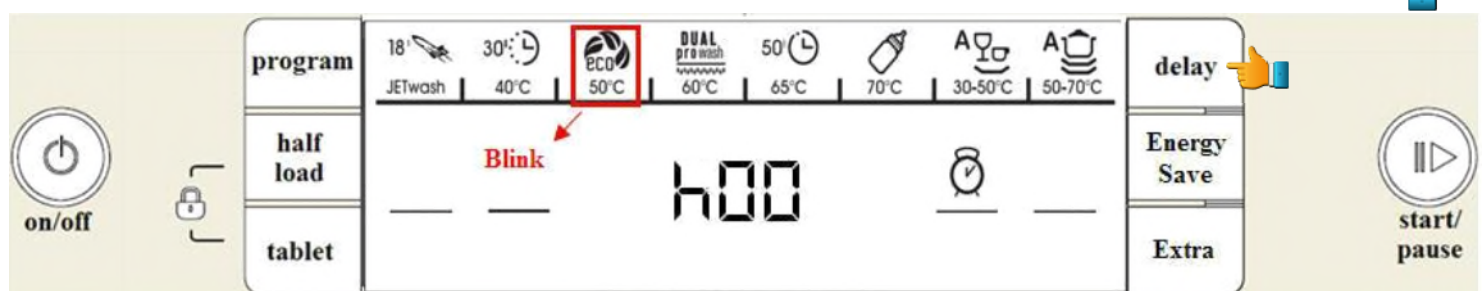

If user hold pressing continuously, delay timer starts counting faster (acceleration is proportional to the hold pressing time), Even a long period of time pressed to delay button, counter stops at “ h:00”.

6.8 EXTRA FAST/ SILENT OPTION:

Extra fast and extra silent options can be selected only at the beginning of program. They cannot be added.

Note: If activated, extra silent option can be removed within washing period. However, extra fast cannot be removed.

Extra fast and extra silent options are not compatible functions with each other. So, they are not executed together in the same washing cycle.

Extra fast/silent option is enabled by firstly pressure of **Extra button**.

Not: When this option is tried to be selected with a not corresponding program, the buzzer sound “**voice_4**” is activated to warn that this is not a valid command.

When Extra button is pressed firstly, fast icon is shown on led module



When Extra button is pressed secondly, fast icon is disappear; Silent icon is shown on module



When Extra button is pressed thirdly, fast icon and Silent icon are disappear on module



6.9 TABLET

Tablet option is selectable at any time. If it is pressed during a washing program the program will execute the following steps with “tablet” functions instead of the normal.

Tablet option is enable by firstly pressure of **tablet button** (tablet icon lights up).

Not: when this option is tried to be selected with a not corresponding program, the buzzer sound “voice_4” is activated to warn that is not a valid command.



Tablet option is disable by secondly pressure of **tablet button** (tablet icon lights disappear).



When selecting a option, if the option matches with non suitable program (ex. Quick 30'– Tablet) and user tries to activate the option, related option icon blinks once and gives voice alert (Voice_4)

6.10 CHILD LOCK

Child lock is enable by contemporary pressure of “half load” and “tablet” buttons in the display card for 3”.

At the end of 3 seconds, “CL” is shown in the display for 2sec and all buttons are locked.

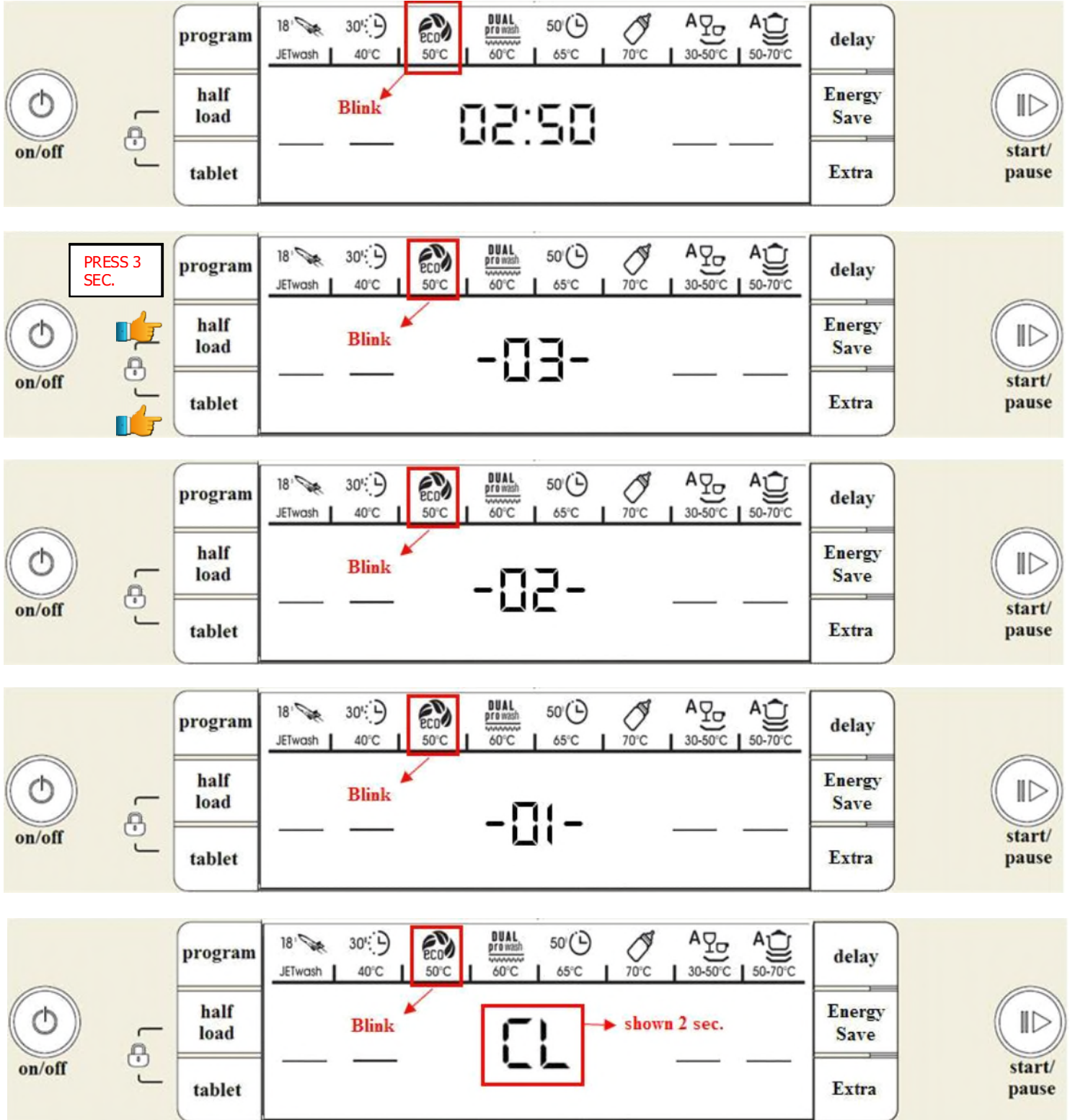

When lock is enabled and any button is touched “CL” is shown in the display for 2” by giving voice alert (VOICE_4) then Child Lock icon ON.

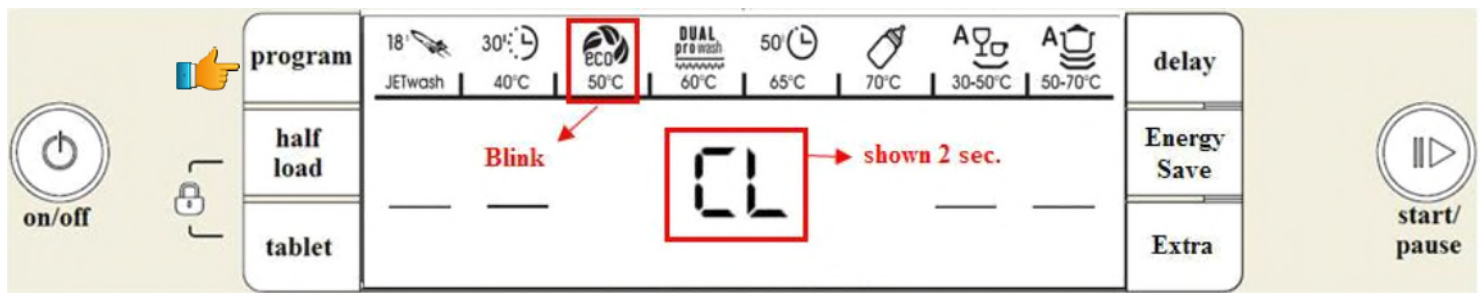

Child lock is disabled by contemporary pressure of “half load” and “tablet” buttons in the display card for 3”. At the end of 3 seconds, “CL” is shown in the display for 2sec and all buttons are unlocked.

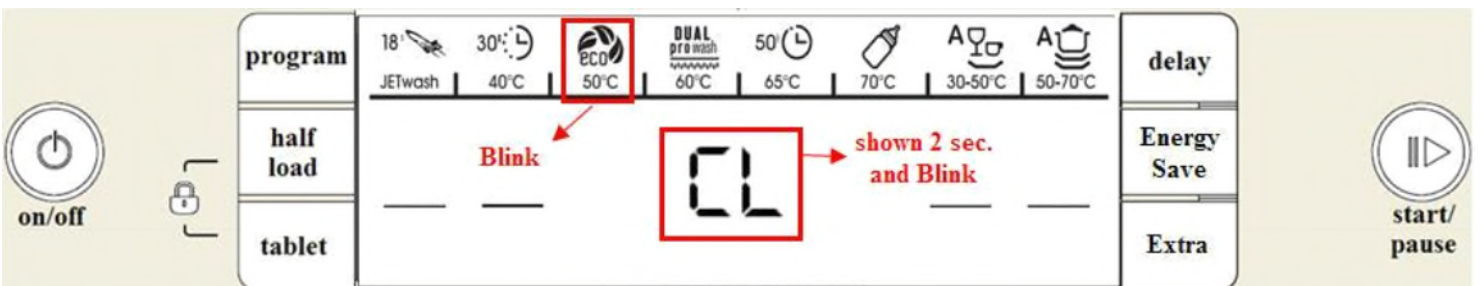
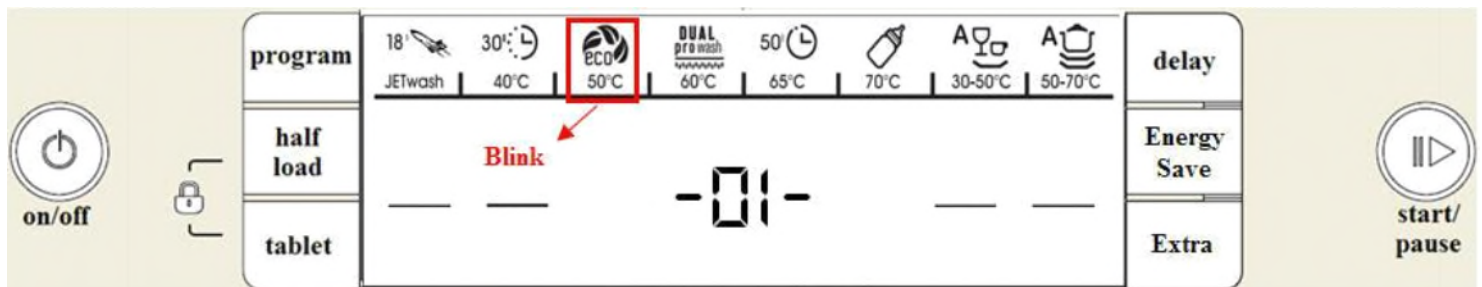
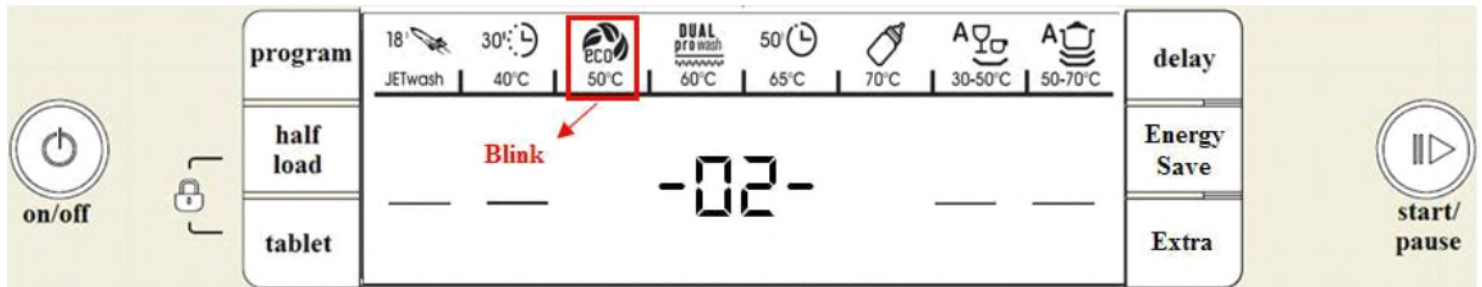

Sometimes, it may not possible to push these two options at the same time to activate Child lock. Probably, the user can push one button a little bit earlier than another. Hence, we request from you to enable some delaying between these two buttons when user push these options to activate childlock. I.e: It is OK for us to activate child lock when user first presses half load and then tablet button or vice versa.

Child lock specifications:

1. Child lock is activated when machine is in standby position. If machine is turned off/on, child lock becomes deactive and machine is in standby position.
2. Child lock is activated while program is running. If machine is turned off/on, child lock is still active and machine continue to wash.

- Child lock is activated while program is running. At the end of program, child lock is still active. CL is shown when user presses a button.
- Child lock is activated while program is running. If machine is turned off/on at the end of program, child lock becomes deactive and machine is in standby position.
- Child lock is activated while program is running. When user enter salt/rinse aid menu at the end of program, CL is not active. CL warning is not given.

6.11 BUZZER VOICE DEFINATION

Voice	Specification	
Voice_1	MELODY	Switched-On voice
Voice_2	SHORT BEEP	Push buttons voice
Voice_3	LONG BEEP	Approval voice
Voice_4	TWO SHORT BEEPS	Fault voice
Voice_5	MELODY	End of program voice
Voice_6	THREE SHORT BEEPS	Count down voice

6.12 INNER LIGHT OPTION:

Machine must be ON position during activation and deactivation of inner light modes.
 Note: open or close position of the door is not important

How to change from “ECO MODE” to “NORMAL MODE” for Inner Light option in 60cm T3 models :

- First energize the machine via main switch (if it is in OFF position).



- Press “Delay” and “Energy Save” buttons simultaneously for 3 seconds.

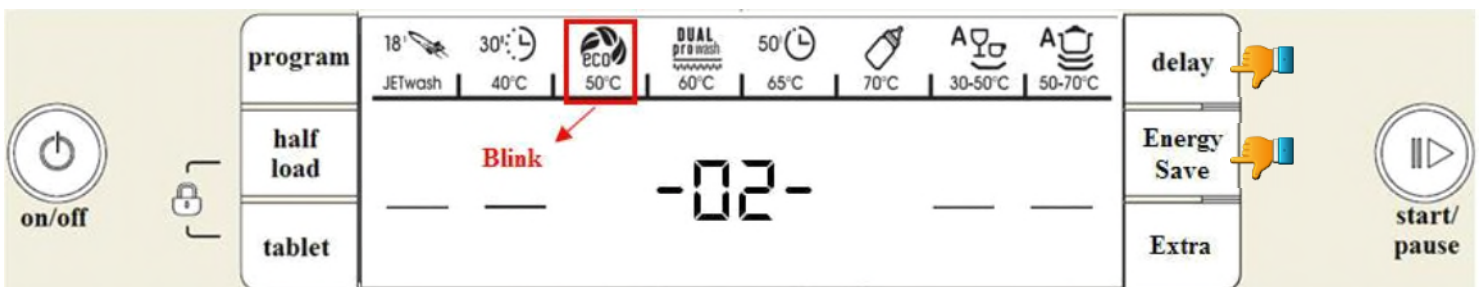

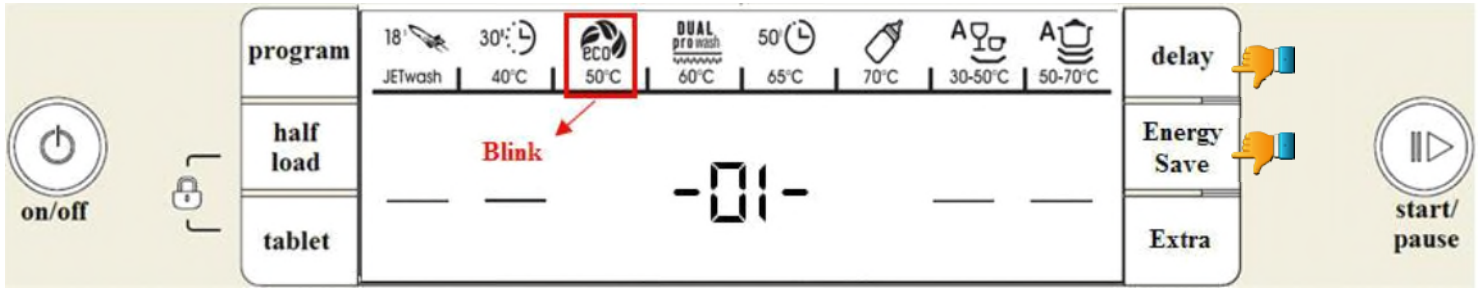

- “IL: 00” will be shown in the display for 2 seconds to show the “Normal Mode” is selected for inner light option.



- After “Normal Mode” is selected, the inner light will be ON as long as the machine is energized and machine door is open.
- After 3 seconds, machine is exit from eco mode settings

How to change from “NORMAL MODE” to “ECO MODE” for Inner Light option in 60cm T3 models :

- First energize the machine via main switch (if it is in OFF position).



- Press “Delay” and “Energy Save” buttons simultaneously for 3 seconds.



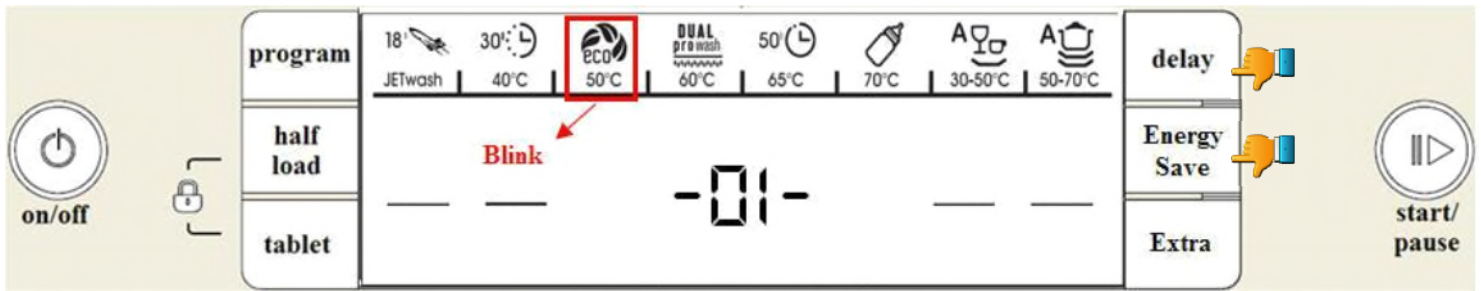

- “IL: 01” will be shown in the digit display for 2 seconds to show the “Eco Mode” is selected for inner light option.



- Also inner light turns OFF and ON again (blinks momentarily) to show this selection is activated.
- After “Eco Mode” is selected, the inner light will be ON for 4min after machine door is opened and then turns OFF.
- Machine’s power must be off to exit inner light control mode
- After 3 seconds, machine is exit from eco mode settings

If any user intervention occurs such as pressing buttons, Eco Mode cycle starts from beginning (inner light is ON for 4min and then becomes OFF again)

Note: Factory setting for inner light is set to “IL: 01”.

Note: **Light Module (TY9)** is introduced to execute this specialist feature.

Note: Eco mode can be adjusted during working or stand by

6.13 IONIZER

Ionizer function is activated/deactivated by pressing “Extra” button for 3”. display shows the countdown from 3 to 1. When it is activated, display shows “Ion”. Also, ionizer can be deactivated by turning machine off and on.

T34 - T35



When the door is closed and the function is selected, ionizer function will start. There is no need to press Start/Pause button.

Ionizer does not work together with any program or not executed in any program. When ionizer active, user cannot select/add any option.

The function will follow below loop and if there is no intervention, it continues until 24 hours is completed.

-During 5 minutes(Between 0-5 minutes): ionizer+mini fan+turbo fan will work.

-During 55 minutes(Between 5-60 minutes): ionizer+mini fan+turbo fan will not work.

After 24 hours, it is automatically deactivated.

When ionizer deactivated, machine is in standby position.

When the door is open and ionizer is activated, ionizer led and inner light become on. Also, “Ion” text blinks. Ionizer function pauses if the door is open. To continue, the door should be closed

7. REGENERATION CYCLE

When it occurs the regeneration valve works after last rinse and during the drying steps. There are 6 hardness levels.

Water Hardness level	Litres
Level 1	Never
Level 2	116 lt
Level 3	64 lt
Level 4	52 lt
Level 5	46 lt
Level 6	16 lt

The consumed litres are counted by flow meter impulses.

In case of flow meter broken, the litres corresponding at the flow meter time out are used

If user cancels a program during regeneration or after regeneration and before resin wash, at the beginning of the next program the dishwasher performs the resin wash to remove the salty water from the resin chamber. The resin wash will be: load 2 lt of water with drain pump on. During the resin wash the circulation Pump must be off.

Regeneration is not performed at prewash program

If l water hardness level is changed from lower to higher, regeneration cycle is performed at the end of the first program

If l water hardness level is changed from higher to lower, regeneration cycle is not performed at the end of the first program.

Regeneration is performed after water level reach to value of level

- If Water hardnes level is 5 or 6
 - First regeneration step is performed 0,2lt water
- If Water hardnes level is 2 or 3 or 4
 - First regeneration step is performed 0,1lt water
- If Water hardnes level is 1
 - Regenartion step is not performed

-The consumed litres are counted by FLM impulses.

-In case of FLM broken, the liters corresponding at the FLM time out are used. (2,1 lt + 2,5 lt).

-In case of "Tablet" option is ON ;

- *If the level set is less than L4: the regeneration cycle is not performed, but the quantity of consumed water is counted. When the target value is reached, at the first cycle without the "Tablet" ,the regeneration cycle is performed.
- *If the level set is equal or more than L5: the regeneration cycle is performed when the quantity target is reached.

-If the washing program is a "prewash program", the regeneration cycle is not performed.

-If user cancels a program during regeneration or after regeneration and before resin wash, at the beginning of the next program the dishwasher performs the resin wash to remove the salty water from the resin chamber. The resin wash will be: load 2 lt of water with drain pump on.

-During the resin wash, the circulation Pump must be OFF .

-If the level of regeneration step is incremented, (for ex:from level3 to level 6) ,at the end of the next washing cycle, it must perform resin wash.

-If the regeneration level is decremented, (for ex: from level4 to level 3); checked how much water used until then and according to new level, how much water will be used more for resin wash is calculated.(level 3=64 lt- used liters until then).

-During waiting step of regeneration process, end user open/close the door or Power OFF /ON condition, program goes to END, but next step of washing cycle starts with resin wash, so that water level resets to zero and re-counts down from corresponding water level.

- When there is no flowmeter connection (by removing flowmeter cable), Electronic card saves the water as 4,58 lt per step.

-If there occurs regeneration step after the programs without drying step or programs having less than 15min drying step, at the end of the program (before reg cycle) the duration must be corrected from 0:01 to 0:15 and recount down during reg step.

8. WATER HARDNESS SET

Only service can execute this procedure.

Level	WATER HARDNESS
1	L:01
2	L:02
3	L:03
4	L:04
5	L:05
6	L:06

→ Power OFF; pressure program selection button.



→ Power ON and continue to pressure program selection button at least for 3”.



→ If “Hardness set” is recognized “SL” is shown for 2”.



→ Release program selection button. The last setting level is viewed*.

→ If it is the first hardness set, hardness level is Level 3.



→ Pressure “Program button” button to set the desired level.



At any pressure of “Delay” button hardness level is incremented (max. “L:06”).



For save the hardness setting, press the On/Off button.



9. RINSE AID SET

- Power OFF; pressure program selection button.
- Power ON and continue to pressure program selection button at least for 5”.
- If “Rinse aid set” is recognized “rA” is shown for 2”.
- Release program selection button. The last setting level is viewed*.
- If it is the first rinse aid set, Default rinse aid level is 4 which corresponds to 4,5 cc.
 - At any pressure of “Program” button, rinse aid level is increased.
 - At any pressure of “Delay” button, rinse aid level is decreased.
 - In order to save the rinse aid setting, press the On/Off button.

Level	Display
1(0cc)	r:01
2(1,5cc)	r:02
3(3cc)	r:03
4(4,5cc)	r:04
5(6cc)	r:05

If the rinse aid tank is empty and user sets rinse aid level as 1(0cc), "lack of rinse aid" warning is not shown.

Sliding dispenser dosages are shown below in detail.

1 rinse aid dosage is performed when dispenser is ON during 8" and OFF during 8". =>1,5cc

2 rinse aid dosages are performed 8" ON-8" OFF-8" ON-8" OFF=>3cc

3 rinse aid dosages are performed 8" ON-8" OFF-8" ON-8" OFF-8" ON-8" OFF=>4,5cc

4 rinse aid dosages are performed 8" ON-8" OFF-8" ON-8" OFF-8" ON-8" OFF-8" ON-8" OFF =>6cc

Action		Old		New(Sliding dispenser)	
Detergent cover opening:		5"		0.3"	
Rinse aid dose:	Dose setting:	Manual in the dispenser		Automatic in the software	
	Dose quantity and time to delivery	1 - 1cc	25"ON; 2"OFF; 25"ON For each setting from 1 to 6	1 - 0cc	OFF
		2 - 2cc		2 - 1.5cc	8"ON; 8"OFF
		3 - 3cc		3 - 3cc	8"ON; 8"OFF
		4 - 4cc		4 - 4.5cc	8"ON; 8"OFF
		5 - 5cc		5 - 6cc	8"ON; OFF

10. SERVICE TEST

Only service man can execute this procedure.

Power OFF; hold press S/P button.



Power ON while pressing S/P button. Hold pressing at least for 6".

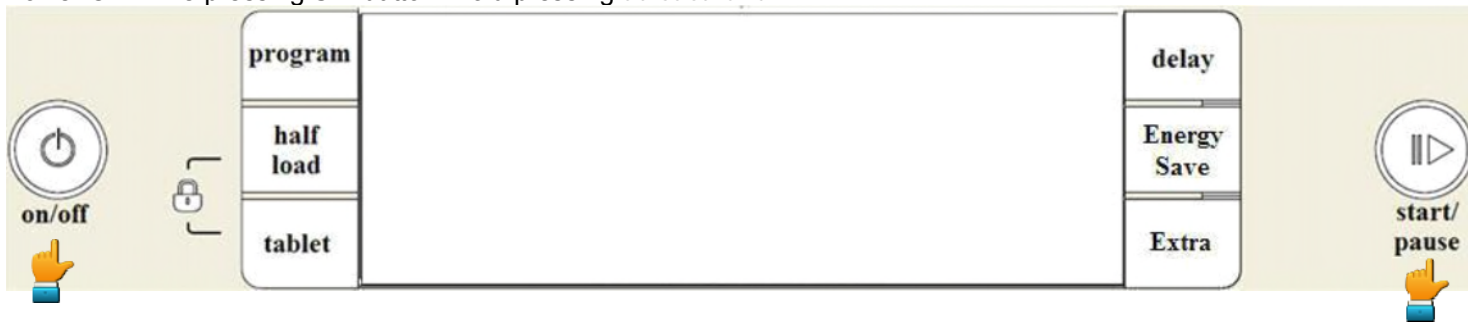

When "Service test" routine is recognized "SP" is visualized on the LED Module and Service test starts.



During the first 6" of test, if a failure code is stored in memory, its codification is shown. Also at the end of the test if an error occurs, its error code and name are visualized on LED Module.

Step	TEXT	Time	Tested Load
0		6"	Before start, the code of last error is visualized (see below)
1	Drain Pump 6s.	6"	Drain pump.
2	Water Fill 1m.	~ 1'	Flow meter; Inlet Valve;
3	Water Fill+Wash 25"		Flow meter; Inlet Valve; Pressure Switch;
4/□	Turbidity sense	20"	Measure of turbidity sensor
5	Wash+Dispenser 1m.	1'	Circulation pump; detergent dispenser.
6	Wash+Heat 5m	5'	Heater (PSW); NTC; diverter (position).
7/8	Reg.Valve+T.Fan+drain pump 1m.	1'	Regeneration Valve + Turbo Fan +drainpump
9	Water V+ Drain 1m20s	1'20"	Water Valve ; Drain pump ; pressure switch.
10	Drain Pump 20s.	20"	Drain pump
11	Service Test End		Error code or End led visualized on LED Module

In service test the unsuccessful heating failure routine works with reduced time of recognize (first measure at 2'20", second measure t 4'20")

LED Module displays the step numbers of service test;



Step 1



Step 2



Step 10

If during the service test, the door is opened, "SP" and "SP:nn" (nn stands for step number) are shown alternately on LED Module.



10.1 CANCELLING SERVICE TEST

Canceling: During a Service Test; press **S/P** button for 3sec. While pressing S/P button (during 3sec.) display shows the countdown from 3 to 1. After 3sec , display shows ;





- Display shows “00:01” at the time zone and draining will be executed
- “END” icon and bar on the right side are blinks,



- At the end of the cycle, the “END” icon will be activated
- Display shows “00:00” at the time zone



It is also possible to cancel the service program by switching OFF the machine. When machine is switched ON again, it is ready to select and start a new program.

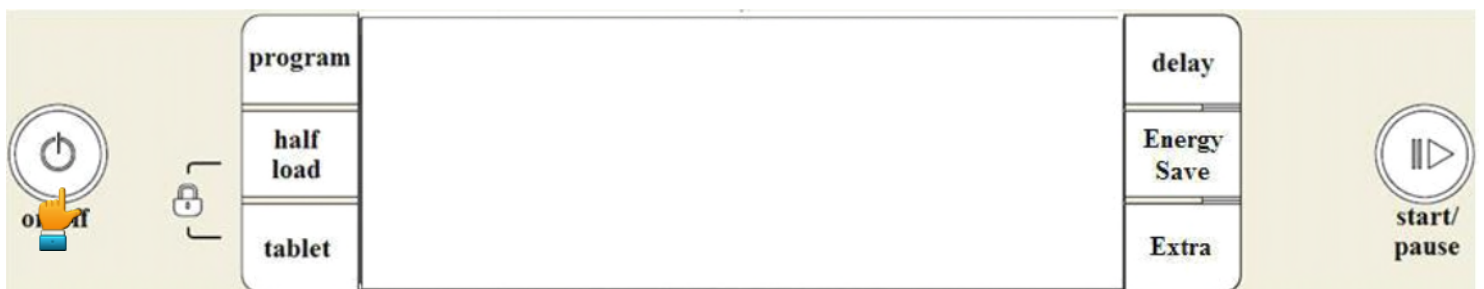

10.2 SERVICE FAILURE CODES MEMORY

It is only possible to enter this mode start of the SERVICE PROGRAM (first 6” of test). It’s codification is shown by pressing “Delay” button. It will be possible to see last 6 faults. Last 6 failure codes are stored in memory.

6” will be refreshing every press of “delay” button .

During the first 6” of test, if a failure code is stored in memory, its codification is shown. If any failure does not occur at the end of service test, previous failure codes stored in the memory should be cleaned. Namely, user does not see any failure code.

When “Service test” routine is recognized, “SP” is shown on the LED Module and Service test starts.



It will be possible to see last 6 faults by pressing "Delay" button.



To cancel this mode and return back the normal usage condition, machine must be **switched OFF**. When machine switched ON again it is now in ready condition to select and start a new program.

10.3 SERVICE FAILURE CODES

Name	TEXT	Notes
Overflow	F:00 Water Overflow	In the normal work this failure is not visualized.
Leakage	F:01 Water Leakage	
Draining time out	F:02 Drain failure	
Presence of Flow meter impulses	F:03 Water input	
Absence of Flow meter	F:04 No Water Impulse	In the normal work this failure is not visualized.
Empty Level	F:05 Inadequate water	
Re-Fill time out	F:05 Inadequate water	
NTC ca/cc	F:06 Heater sensor	
Overheating	F:07 Over Heating	
Unsuccessful heating	F:08 No Heating	
Diverter opened	F:09 Diverter Failure	
Turbidity Sensor	F A:Turbidity Sensing	In the normal work this failure is not visualized.

Parameter set salt incorrect	S E: Salt Set Failure	In the normal work this failure is not visualized.
CK Parameter	F E E-Card Failure	
Auto door	FC: Auto door Failure	In the normal work this failure is not visualized.
High Voltage	HI: High Voltage Failure	In the normal work this failure is not visualized.
Low Voltage	LO : Low Voltage Failure	In the normal work this failure is not visualized.

11. FAILURE ROUTINES (SOFTWARE CLASS "A")

11.1 CODE FAILURE – GENERAL INTERVENTION TABLE

N°	Name	Exit of failure state	Service Call
1	Switch door open	Door closing	NO
2	Delay after door closing	7" delay before restart prg in heating step	NO
3	Overflow Leakage	Overflow signal gets off	NO
		OFF/ON	YES
4	Draining time out	OFF/ON	YES
5	Presence of Flow meter impulses	Flow Meter signal gets off.	NO
		OFF/ON.	YES
6	Absence of Flow meter impulses	Pressure switch on Full.	NO*
		Pressure switch on Empty. OFF/ON	NO/YES
7	Level Empty	Level doesn't reach full	NO/YES
8	Re-Fill	3 Re – fill in the same washing step	NO/YES
8	NTC ca/cc	OFF/ON	YES
9	Overheating	OFF/ON	YES
10	Unsuccessful heating	OFF/ON	YES
11	Diverter opened	OFF/ON	YES
12	CK Parameters	OFF/ON	YES

*Cycle could be executed with a filling time.

11.2 FAILURE ROUTINE

If a failure is recognized:

- Stop all devices;
 - Stop program flow.
 - Drain Empty + 30" with circulation pump on
 - If the failure requires the termination of the washing program:
 - Stop all the devices.
 - Start to visualize the failure code.
 - If the failure doesn't require the termination of the washing program:
 - Stop all the devices.
 - Re-Start the washing program.
- If it is necessary it performs the *Re-Fill routine*

11.3 RE-FILL ROUTINE

After a forced drain (ex: a failure routine) if the dishwasher was in wash before the drain it performs the re-fill routine:

When Flowmeter OK Procedure: Drain take 3lt water(time out 420" in 60cm diverter model) start circulation Pump take additional 1 lt (total 4lt) (time out 100") Continue the washing cycle from where it remained.

When Flowmeter NOTOK Procedure: like Full without flowmeter condition.

Take 50" water → start circulation pump → If PSW ON: take additional 60".

12. DESCRIPTION OF THE FAILURES

12.1 OPENED DOOR SWITCH

Recognize: if door is opened with a started program.

Action: Wait.

Exit: Closing door.

T33_1 – T34_1	-
---------------	---

Service: NO

12.2 DELAY IN RE-START PROGRAM

Recognize: if door is opened and re-closed in a heating step.
Action: Restart program without any delay if temp. Is less than 45 C
 Wait 8" before restart program if temp. Is equal or more than 45 C
Exit: Closing door.
Service: NO

12.3 OVERFLOW/LEAKAGE



Recognize: 5" with overflow pressure sensing = on.
Action: Go to **Failure routine**.
Exit: If overflow signal gets off until **failure routine** finishes (cause is overflow): washing program re-starts. It re-fills water according to **Re-Fill routine** and it continues to wash.
 If overflow signal persists until **failure routine** (cause is leakage): OFF/ON.

Only for leakage

	Water Overflow/Leakage
T33_1 – T34_1	F:00 / F:01

Service: NO if overflow.(it is shown in only service mode)
 YES if leakage.

12.4 DRAINING TIMEOUT



Recognize: 180" with drain pump ON and circulation pump ON with pressure sensing in full level position.
Action: Go to **Failure routine**.
Exit: OFF/ON.

	Drain failure
T33_1 – T34_1	F:02

Service: YES

12.5 PRESENCE OF FLOW METER IMPULSES AND INLET VALVE SWITCHED OFF



Recognize:

When the triac valve is OFF and flowmeter gives some impulses (more than 500cl) □ enter in the failure routine and drain all water (WIV 12secOFF/12sec ON) □ try to load again correct amount of water inside the machine □ if failure persists: drain all water (WIV 12secOFF/12secON) □ Show failure code (End of routine) □ if impulses still persist □ Drain Pump is OFF 100sec □ Drain pump is ON 60sec □ Drain Pump is OFF 100sec → → ↓
 ↑↑↑←←←←←←←←←←←←←←←←←←←←←←←←←←←←←←
 Continue this loop until the flowmeter pulsess stop.

Action: Go to **Failure routine.**
Exit: OFF/ON.

	Water input
T33_1 – T34_1	F:03

Service: YES

12.6 ABSENCE OF FLOW METER IMPULSES.

Procedure : Take 50" water → start circulation pump → If PSW is FULL: take additional 60" → Continue with the washing cycle. If PSW is not FULL after 50" then go on taking water for total time out 150" → If PSW is FULL in the 150" time out then take 60" more water

Recognize: After 50" (time out) of load without impulses by the flow meter, circulation pump starts. If pressure switch goes to full level: fill for Full +60" and the washing program continues.

Action: -
Exit: -
Service: NO.
Note: It is only shown in service mode

12.7 LEVEL EMPTY WITHOUT FLOW METER IMPULSES (PERHAPS TAP CLOSE).



Procedure: Take 50" water → start circulation pump → If PSW is not FULL after 50" then go on taking water for total time out 150" → if again PSW is OFF/EMPTY level → Then enter in the failure routine and then show the related error code as described failure routine point.

Recognize: After water load starts, if pressure switch doesn't go to full level in 150".
Action: Go to **Failure routine.**
Exit: OFF/ON.

	Inadequate water
T33_1 – T34_1	F:05

12.8 RARELY FLOW METER IMPULSES (PERHAPS LOW WATER PRESSURE).



General Procedure:

With rarely flow meter impulses (time out of absence of flow meter impulses doesn't expire) > if it doesn't reach the **first quantity** of required water (2,5l for 60cm diverter models) within the time out (420" for 60cm diverter models) > Go to the Failure routine and then show failure code.

Procedure for PSW full level is reached:

If it reaches first quantity level within the dedicated time > it continues to take water to reach required level of water (**second quantity**) within timeout 100" > if it doesn't reach the **second quantity** of required water according to the washing cycle within the time out (100") , but PSW reaches the **FULL LEVEL** > Hence stop water intake and continue washing with the following steps and do not show any failure.

Action: Go to **Failure routine**.

Exit: OFF/ON.

	Inadequate water
T33_1 – T34_1	F:05

Service: Not necessary if the reason is a momentary.
YES in the other cases.

12.9 LEVEL EMPTY AND RARELY FLOW METER IMPULSES.



Procedure for PSW Empty level persists:

If it reaches first quantity level within the dedicated time > it continue to take water to reach required level of water (**second quantity**) within timeout 100" > if it doesn't reach the FULL level in this step and PSW is still at **EMPTY LEVEL** > Continue for more 30" to reach FULL level > If full level is reached, continue with the following steps without failure, but if it cannot reach the FULL level also within 30"> go to the failure routine and then show related failure code.

Recognize: With rarely flow meter impulses (time out of absence of flow meter impulses doesn't expire) it doesn't reach the second quantity of required water related to the washing cycle) within the time out (100")

Action: Go to **Failure routine**.

Exit: OFF/ON.

	Inadequate water
T33_1 – T34_1	F:05

Service: Not necessary if the reason is a momentary.
YES in the other cases.

12.10 LEVEL EMPTY AND REGULAR/RARELY FLOW METER IMPULSES.



Recognize: With flow meter impulses (time out of absence of flow meter impulses doesn't expire) it reaches the second quantity of required water related to the washing cycle) but it doesn't reach the full level within the time out (30")

Action: Go to **Failure routine**.

Exit: OFF/ON.

	Inadequate water
T33_1 – T34_1	F:05

Service: Not necessary if the reason is a momentary.
YES in the other cases.

12.11 RE-FILL



Re-Fill routine:

When Flowmeter OK Procedure: Drain >take 3lt water(time out 420" in 60cm diverter model) > start circulation Pumpà take additional 1 lt (total 4lt) (time out 100") >Continue the washing cycle from where it remained.

When Flowmeter NOTOK Procedure: like Full without flowmeter condition.

Take 50" water → start circulation pump → If PSW ON: take additional 60".

If psw is not FULL after 50" then go on taking water for total time out 150" if again PSW is OFF then → enter failure routine and show related error code. May be tab is closed. If PSW is FULL in the 150" time out then take 60" more water (from thepoint where PSW level become FULL).

Recognize: During a washing step, if pressure switch goes from full level to empty level **Failure routine** start. Wash restarts with the **Re-Fill routine** (3I+1I).
If pressure switch goes from full level to empty level for 3 times during the same washing step failure is recognised.

Action: Go to **Failure routine**.

Exit: OFF/ON.

	Inadequate water
T33_1 – T34_1	F:05

Service: Not necessary if the reason is a momentary (ex. An upside down pot).
YES in other situations.

12.12 NTC OPEN OR SHORT-CIRCUIT



Recognize: Recognition of open or short-circuit NTC (-20°C/86°C). Test is executed during all the program flow.

Action: Go to **Failure routine**.

Exit: OFF/ON.

	Heater sensor
T33_1 – T34_1	F:06

Service: YES

12.13 OVERHEATING



Recognize: Water temperature $\geq 77^{\circ}\text{C}$. The test is done during all the cycle.
Action: Go to **Failure routine**.
Exit: OFF/ON.

	Over Heating
T33_1 – T34_1	F:07

Service: YES

12.14 UNSUCCESSFUL HEATING



Recognize: During the heating phases, after the first **420"**, if water temperature increases less than 2°C or if it is less than 0° . The first valid value to check is read after **120"** from the beginning of the heating step.
 The test is executed only if the measured temperature is lower than 60° . After door opened and reclosed during heating, temperature and time value which are read before door is opened must be cleared. Also, the control routine will start from beginning of failure routine.
Action: Skip the heating step.
Note: The test is repeated in all the heating steps. If in a following step, the heating is OK the failure is cleared. The failure is shown at the end of the program.
Exit: OFF/ON.

	No Heating
T33_1 – T34_1	F:08

Service: YES

Note: F8 is not sensed and shown in Jetwash 14' program.

12.15 DIVERTER OPEN CIRCUIT



Recognize: 30" with motor of diverter valve ON and diverter sensing doesn't change.
 Action: Go to **Failure routine**.
 Exit: OFF/ON.

	Diverter Failure
T33_1 – T34_1	F:09

Service: YES

12.16 TURBIDITY



	Turbidity Sensing
T33_1 – T34_1	FA

Service: NO

(Only service mode)

12.17 PARAMETER SET SALT INCORRECT



	Salt Set Failure
T33_1 – T34_1	SE

Service: NO

12.18 PARAMETERS CHECK SUM



Recognize: When parameter Check sum is uncorrected
 Action: Go to **Failure routine**.
 Exit: OFF/ON.

	E-Card Failure
T33_1 – T34_1	FE

Service: The problem would disappear after switch OFF/ON of the dishwasher. If it doesn't disappear YES.

12.19. HIGH VOLTAGE FAILURE

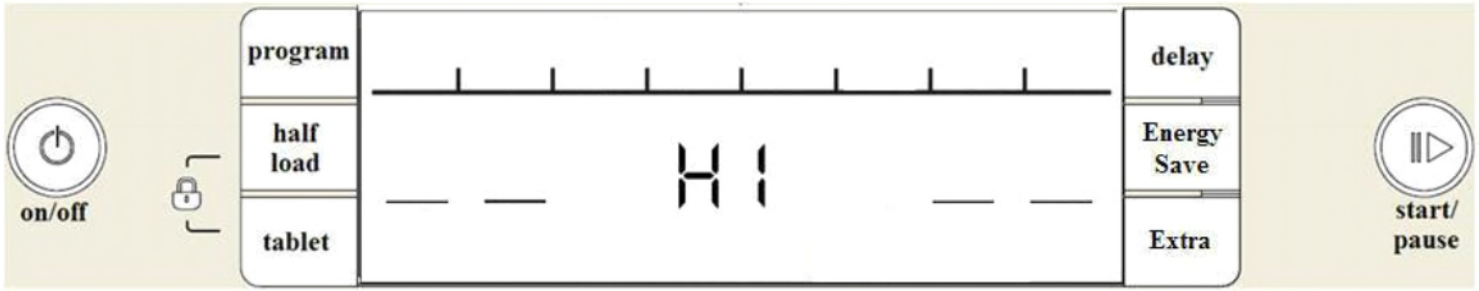

Recognize: When high voltage (above 285V, then 275-285VAC) detected during 3 hours

Action: Go to **Failure routine**.

Exit: OFF/ON.

	High Voltage Failure
T33_1 – T34_1	HI

Service: NO

12.20 LOW VOLTAGE FAILURE

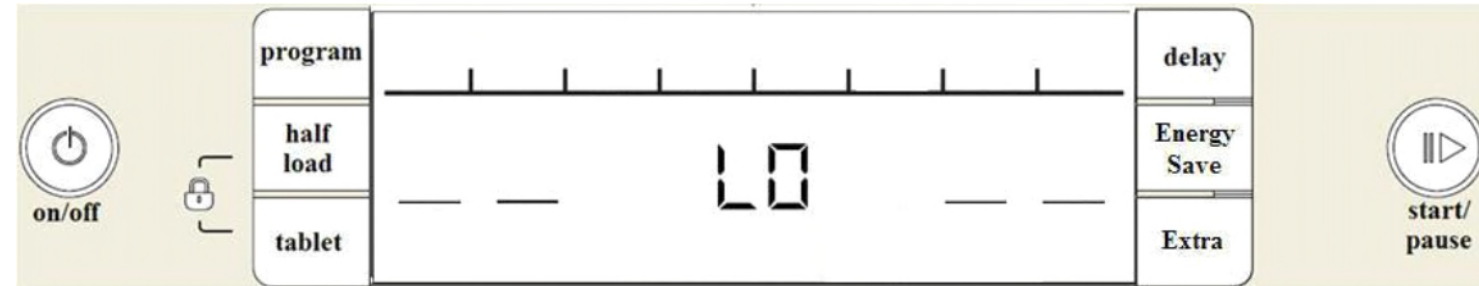

Recognize: When low voltage (blow 145V, then 145-155VAC) detected during 3 hours

Action: Go to **Failure routine**.

Exit: OFF/ON.

	Low Voltage Failure
T33_1 – T34_1	LO

Service: NO

12.21 AUTO DOOR FAILURE

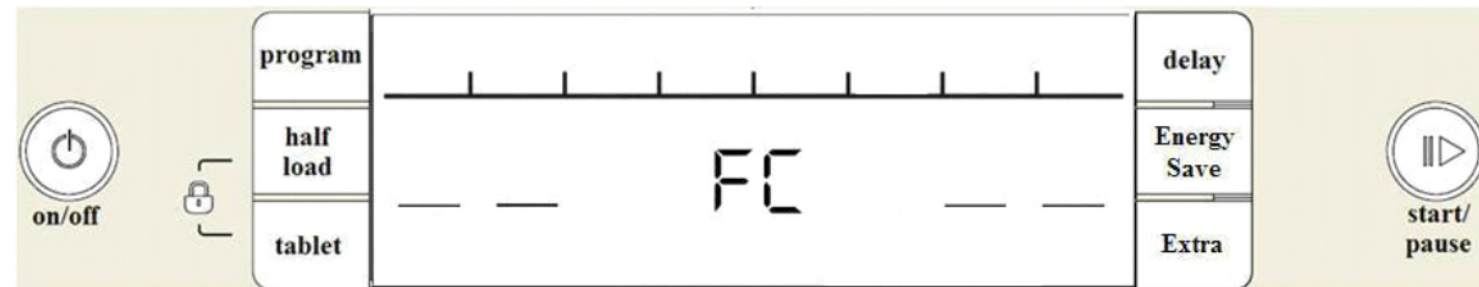

Recognize: When auto door mechanism is activated, the door is not opened

Action: Go to **Failure routine**.

Exit: OFF/ON.

	Auto Door Failure
T33_1 – T34_1	FC

Service: NO

ERROR CODE						ERROR DESCRIPTION	CONTROL
DISPLAY	WASH	RINSE	DRY	END	START/PAUSE		
F5					☀	Inadequate water supply	<ul style="list-style-type: none"> • Make sure the water input tap is totally open and that there is no water cut. • Close the water input tap, separate the water input hose from the tap and clean the filter at the connection end of the hose. • .Water inlet valve filter can be • Water inlet valve can be out of order • There can be a problem with the cable connection of water inlet valve. • Floater switch can be out of order or have a problem with the cable connection. • Pressure switch of the heater casing group can have a mechanical or cable connection problem. • Circulation pump can be out of order or have a problem with the cable connection. • Electronic card can be out of order.
F3		☀		☀		Error of continuous water input	<ul style="list-style-type: none"> • Water inlet valve can be out of order or can not be closed. • Electronic card can be out of order.
F2			☀	☀		The waste water in the machine cannot be discharged.	<ul style="list-style-type: none"> • Water outlet hose is clogged. • Water discharge hose can be out of order. • There can be a problem with cable connection of the drain pump. • Pressure switch of the heater casing group can have a mechanical or cable connection problem. • Electronic card can be out of order.

ERROR CODE						ERROR DESCRIPTION	CONTROL
DISPLAY	WASH	RINSE	DRY	END	START/PAUSE		
F8	☀		☀	☀		Heater Error: Inadequate heat	<ul style="list-style-type: none"> • NTC can be out of order. • Faulty NTC cable connection can be faulty. NTCshort or open circuit. • Thermal protection can be out of order. • Heater can be out of order or cable connection can be out of order.
			☀			Alarm is active against water overflow	<ul style="list-style-type: none"> • Floater switch can be out of order or have a problem with the cable connection. • Electronic card can be out of order.
F1		☀	☀			Alarm is active against water leakage	<ul style="list-style-type: none"> • There can be a water leakage from the tub. • Floater switch can be out of order or have a problem with the cable connection. • Electronic card can be out of order.
F7	☀		☀			Exceed heating problem (water inside the machine is too high)	<ul style="list-style-type: none"> • water inside the machine is >77°C, NTC can be out of order. • Electronic card can be out of order. •
F9	☀	☀				Diverter position problem	<ul style="list-style-type: none"> • Diverter electric contacts can have open circuit • Cable connection of the diverter can be faulty • Electronic card can be out of order.

ERROR CODE						ERROR DESCRIPTION	CONTROL
DISPLAY	WASH	RINSE	DRY	END	START/PAUSE		
F6	☀			☀		NTC faulty	<ul style="list-style-type: none"> • NTC can be out of order. • Faulty NTC cable connection can be faulty. NTCshort or open circuit. • Electronic card can be out of order.
FE	☀	☀	☀	☀		Electronic card parameter faulty	<ul style="list-style-type: none"> • By the Immediate and continuous voltage decreases software variants can not be kept in the memory of electronic card
SE	☀	☀	☀			Electronic card water hardness faulty	<ul style="list-style-type: none"> • Water Hardness is not be adjusted or Water Hardness adjustment can not be kept in the electronic card memory. • Water Hardness should be adjusted by controlling the supply water.
F4		☀				Faulty Flowmeter	<ul style="list-style-type: none"> • Cable connection of flowmeter can be faulty. • Electronic card can be out of order.
FA	☀	☀		☀		Faulty turbidity sensor	<ul style="list-style-type: none"> • Kirilik sensörü kablo bağlantısı hatalı • Turbidity sensor can be out of order. • There can be some soil around the turbidity sensor. • Electronic card can be out of order.
					☀	Door is open	<ul style="list-style-type: none"> • Door lock mechanism can be out order. • There can be a problem with the cable connection of door lock. • Electronic card can be out of order.

13. FAILURE CODES

Coding failure for LED Module:

F:00	Water Overflow
F:01	Water Leakage
F:02	Drain failure
F:03	Water input
F:04	No Water Impulse
F:05	Inadequate water
F:06	Heater sensor
F:07	Over Heating
F:08	No Heating
F:09	Diverter Failure
FE	E-Card Failure
SE	Salt Set Failure
FA	Turbidity Sensing
FC	Auto Door Failure
HI	High Voltage Failure
LO	Low Voltage Failure

*Unsuccessful Heating is shown at the end of the program

14. END TEST PROGRAM

End test is divided in two parts: end test 1 (functionally test) and end test 2 (heating and leakage test).

14.1 END TEST 1

Pressure "Delay button" and "Extra button"



Power ON while pressing to "Delay" and "Extra" buttons at least for 3".



When “End test 1” is recognized “EP” is visualized on the LED Module and End test starts.



- At the end of “end test 1” switch OFF the dishwasher.

Note: During diverter failure: Stop circulation pump just after detergent dispenser activation (at step 41) until the end of program if electronic card

Note: ** Start circulation pump just after turbidity sensor check (at step 92) for 6 sec, if electronic card realize Turbidity sensor failure during turbidity test.

14.2 END TEST 2

When the electronic card is switched on after the end test 1, end test 2 starts.

- 4” of pause
- Heating to reach 62°C with 13’ of time out
- Only circulation pump is on for 10’’ sec
- Drain + Regeneration valve is on 20’’
- End test 2 is finished.

During this phase, failure routine of unsuccessful heating and failure routine of ntc works. If the water temperature doesn’t increase, at the end of 13’, the drain pump will be on.

When the electronic card is switched on after end test 2, it will be in washing mode.

14.3 END TEST 3

After the “End test 2”



When dishwasher is energized, all characters will be activated for production line control.

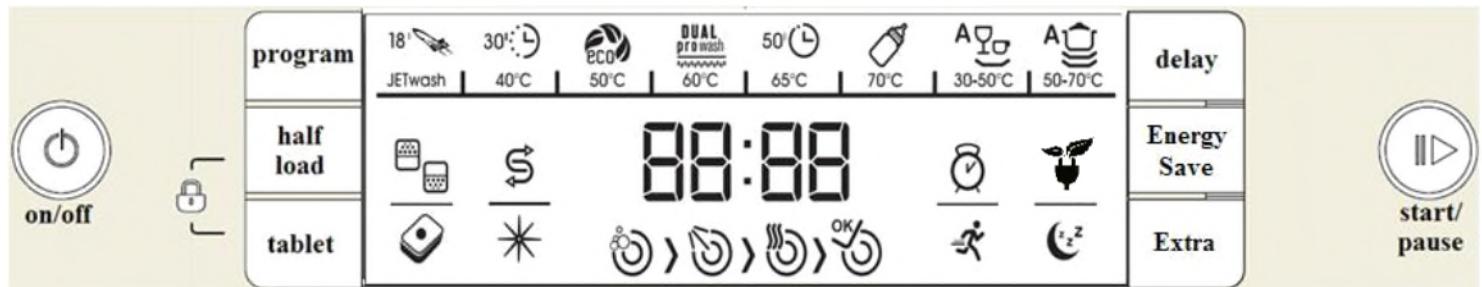

Screen will stay in this condition until energy becomes off.

14.4 MODEL CODIFICATION: T33_1 AND T34_1

LED Mod_1 (T33_1)		LED Mod_2 (T34_1)	
All Led power on test	All Icons are ON	All Led power on test	All Icons are ON
1st combination	Digit 3 and JetWash icon is shown	1st combination	Digit 4 and JetWash icon is shown
2st combination	"JetWash" Icon will be ON	2st combination	" JetWash" ICON will be ON
1st digit combination	All icons are on	1st digit combination	All icons are on
Driverter result with OK condition	"Tablet" Icon will be ON	Driverter result with OK condition	"Tablet" Icon will be ON
Tubidity result with OK condition	"Tablet" Icon will be ON	Tubidity result with OK condition	"Tablet" Icon will be ON

1st combination of T33

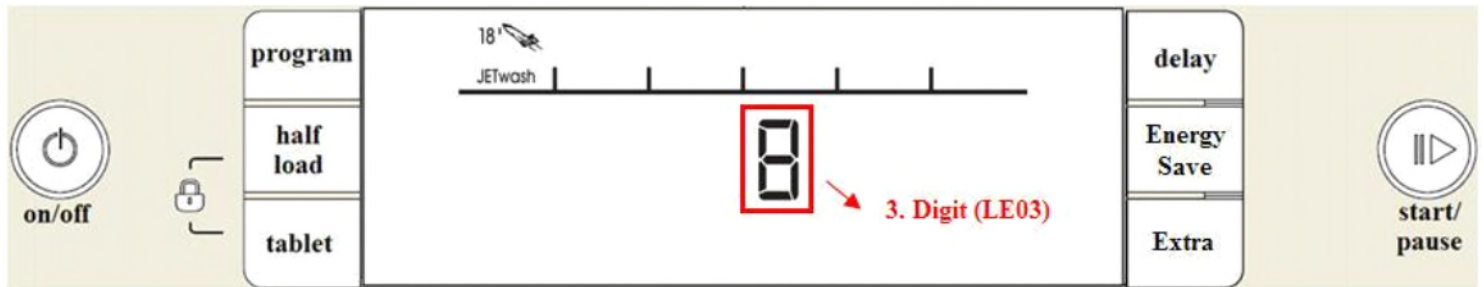

2st combination of T33

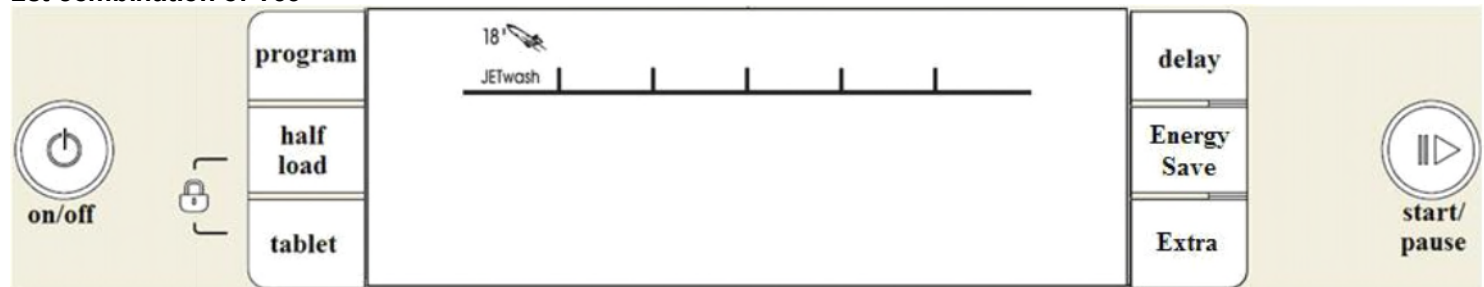

1st combination of T34

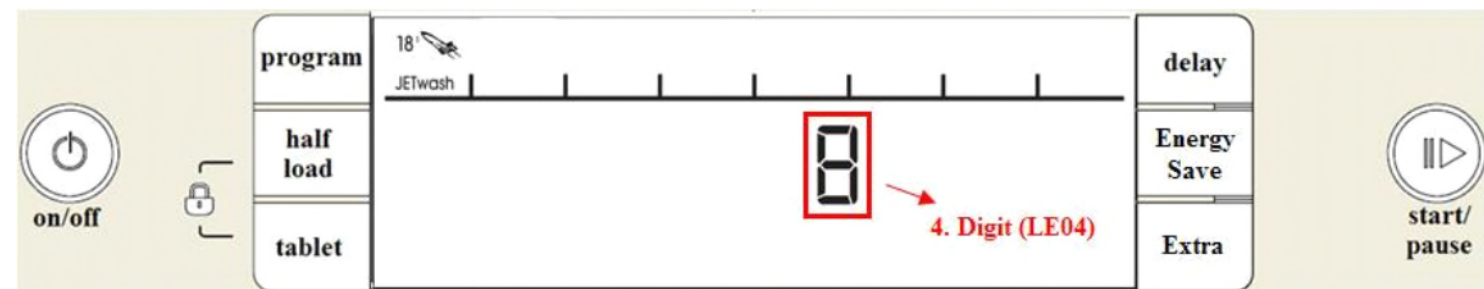

2st combination of T33

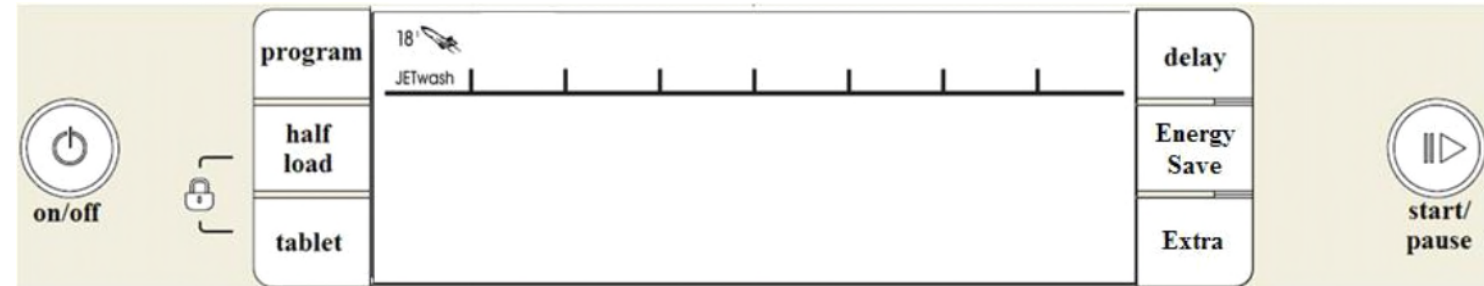

15. MEASUREMENT THE WATER HARDNESS

TEST STRIP;

Open the testing strip.	Run water through your tap for 1 min.	Keep the testing strip in water for 1 sec.	Shake the testing strip after taking it out of water.	Wait for 1 min.	Make your machine's water hardness setting according to the result obtained through the testing strip.
-------------------------	---------------------------------------	--	---	-----------------	--

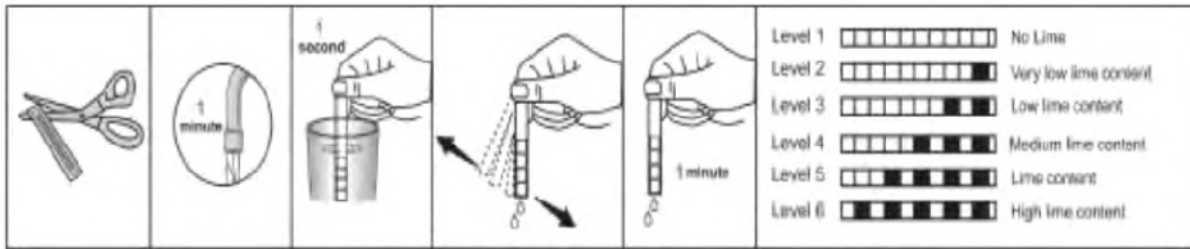

The washing effectiveness of your machine depends on the softness of the tap water. For this reason, your machine is equipped with a system that reduces the hardness in mains water supply. The washing effectiveness will increase when the system is correctly set. To make the system setting, use the testing strip, if it is available, and find the hardness of the mains water supply.

16. FAILURE CODES (Possible Problems)

F1 (ALARM IS ACTIVE FOR OVERFLOW)

FLOATER

- Floater switch can be out of order or have a problem with the cable connection.

TUB

- There can be a water leakage from the tub

ELECTRONIC CARD

- Electronic card can be out of order.

F2 (THE WASTE WATER IN THE MACHINE CANNOT BE DISCHARGED)

DRAIN HOSE

- Water outlet hose is clogged
- Check of the water outlet hose position.

DRAIN PUMP

- Check the drain pump resistance and power values
- There can be a problem with cable connection of the drain

PRESSURE SWITCH

- Pressure switch of the heater casing group can have a mechanical or cable connection problem.

F3 (ERROR OF CONTINUOUS WATER INPUT)

WATER INLET VALVE

- Water inlet valve can be out of order or can not be closed.

ELECTRONIC CARD

- Electronic card can be out of order.

F4 (FLOWMETER FAULTY)

FLOWMETER

- Flowmeter can be out of order.
- Cable connection of flowmeter can be faulty.

ELECTRONIC CARD

- Electronic card can be out of order.

F5 (INADEQUATE WATER SUPPLY)

WATER TAP

- Make sure the water input tap is totally open and that there is no water cut.

WATER INLET HOSE

- Close the water input tap, separate the water input hose from the tap and clean the filter at the connection end of the hose.

- Water inlet valve filter can be clogged.

- Water inlet valve can be out of order. There can be a problem with the cable connection of water inlet valve.

FLOATER

- Floater switch can be out of order or have a problem with the cable connection.

PRESSURE SWITCH

- Pressure switch of the heater can have a mechanical or cable connection problem.

CIRCULATION PUMP

- Circulation pump can be out of order or have a problem with the cable connection. External part can be blocked to the circulation pump.

F6 (NTC FAULTY)

NTC

- Ntc can be out of order.

Ntc cable connection can be faulty. Ntc can be short or open circuit.

ELECTRONIC CARD

- Check the power and resistance value of heater.
- Check the cable connection of the heater.

F7 (EXTREME HEATING UP FAULTY)

NTC

- If the water temperature inside machine higher than 77°C, ntc can be out of order.

ELECTRONIC CARD

- Electronic card can be out of order.

F8 (INADEQUATE HEAT)

HEATER

- Check the power and resistance values.
- Check the cable connection of the heater.

ELECTRONIC CARD

- Check the electronic card

F9 (DIVERTER POSITION PROBLEM)

DIVERTER

- Check the values of the diverter.
- Check the cable connection of the diverter.

ELECTRONIC CARD

- Check the electronic card

FA (TURBIDITY SENSOR FAULTY)

TURBIDITY SENSOR

- There can be some soil around the turbidity sensor.
- Check the cable connection of the turbidity sensor.

ELECTRONIC CARD

- Check the electronic card.

10.1 POOR DRYING

- a) The programme which hasn't got a drying phase; could be selected the customers should be informed about the programmes.
- b) There might be lack of rinse aid compartment.
- c) There can be mechanical or electrical problem with the detergent dispenser.
- d) There can be a problem on the PCB card.

17. REPAIR TECHNIQUES COMPONENTS AND RESISTANCE VALUES

COMPONENTS	C		T		NOTES
ON / OFF SWITCH	0 Ω on component		0 Ω on component		ON/OFF button is pressed
DOOR SWITCH	CN2.9 - CN2.2 0 Ω		KN2.8 - KN2.10 0 Ω		Door is close
PRESSURE SWITCH	CN2.10 - CN2.2	0 Ω ∞Ω	KN2.9 - KN2.10	0 Ω ∞Ω	Full fill water no water
DRAIN PUMP / HANYU	CN2.2 - CN2.4 220 Ω % ±10		KN2.4 - KN2.10 220 Ω % ±10		
DRAIN PUMP / LEILI	CN2.2 - CN2.4 141 Ω % ±10		KN2.4 - KN2.10 141 Ω % ±10		
WATER INLET VALVE	CN2.6 - CN2.9 4200 Ω ± %10 (20°C)		KN2.6 - KN2.8 4200 Ω ± %10 (20°C)		
REGENERATION VALVE	CN2.2 - CN2.7 3560 Ω ± %10(25°C)		KN2.2 - KN2.10 3560 Ω ± %10(25°C)		
SALT SENSOR	CN5.1 - CN5.2	0 Ω NO SALT ∞Ω THERE IS	KN50.10 - KN50.11	0 Ω NO SALT ∞Ω THERE IS SALT	Measure just on the electronic
HEATER	29.1 ± 1,5 Ω		29.1 ± 1,5 Ω		Measure just on the component
DETERGENT DISPENSER	2300 Ω ± %10 (25°C)		2300 Ω ± %10 (25°C)		Measure just on the component
CIRCULATION PUMP	CN2.3 - CN2.9		KN2.3 - KN 2.8		Primary winding Secondary winding (from the component)
SET NTC SENSOR	CN32 CN3.1		KN 50.1 KN 50.2		
FAN MOTOR	CN 6.2 - CN 2.9		KN 6.2 - KN 2.8		
DIVERTER	CN 6.1 - CN 2.9 10500 ± %7 Ω		KN 6.1 - KN 2.8 10500 ± %7 Ω		
RINSE AID SENSOR	CN 5.3 - CN 5.2	0 Ω NO RINSE AID ∞Ω THERE IS RINSE	KN 50.8 - KN 50.9	0 Ω NO RINSE AID ∞Ω THERE IS RINSE AID	Rinse aid off Rinse aid on
FLOATER (MICROSWITCH)	CN2.1 - CN 2.5 CN2.1 - CN 2.4	0 Ω ∞Ω	KN2.5 - KN 2.10 KN2.4 - KN 2.5	0 Ω ∞Ω	Microswitch is inactive (no water) microswitch is active (there is water)

MEASURING THE COMPONENTS FROM THE ELECTRICAL CARD

You might measure the components either connectors of electronic card or directly on the component.

Measuring from the connectors of electronic card gives definite result to define the repair. If you know the specialities and values of tester, you can easily determine the repair.



Example;

Probes of the tester should be applied on to the related connectors of the electrical card; control the values according to the resistance value table.

18. DISASSEMBLY

CAUTION! REMOVE ELECTRIC PLUG FROM THE SOCKET DURING THE DISASSEMBLY

Side Panels

Remove the screws fixing side panels

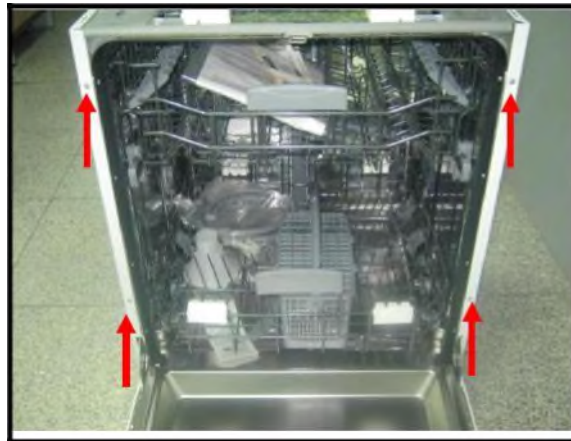

Front Panel

- a) Remove the screws as it shown in the picture.



- b) Pull down the front panel after removing the screws.

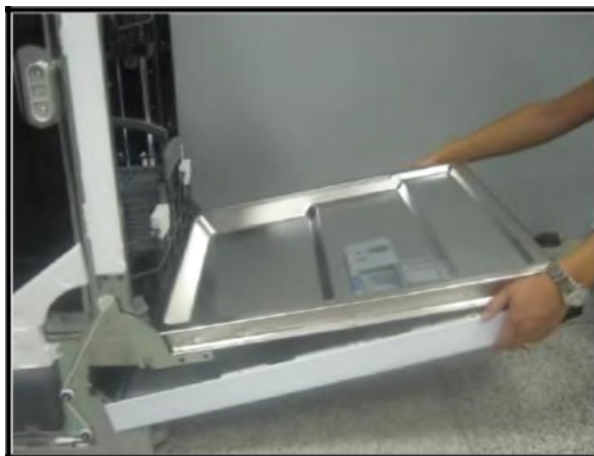

- To remove the side panel, remove the upper plastic hinge and then the above one and pull it up.



Control Panel

- a) Remove 6 screws that fix control panel to the door inside sheet iron.
- b) Remove the control panel group carefully as shown in the picture

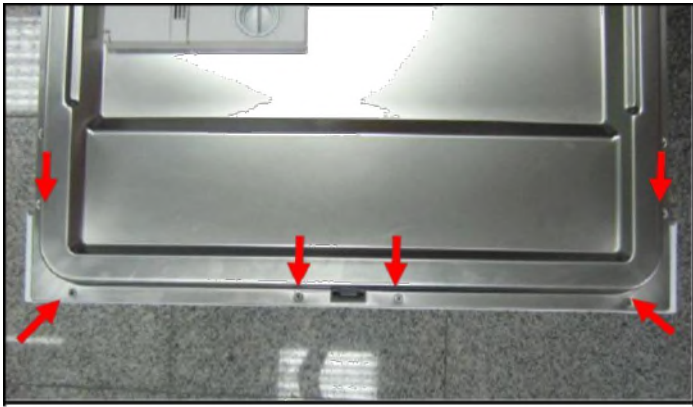

c) Remove the cable connection plastic which fix cable harness to the control panel as shown in the picture.

d) Remove the wires that are connected to control panel group

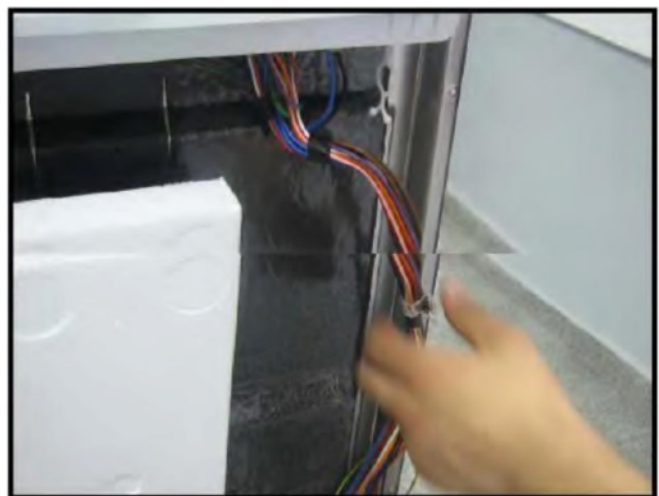

Door Lock Group

a) Remove control panel group

b) Remove two screws that fix the door lock group



Dispenser

- a) Remove the front panel
- b) Remove the wire.
- c) Remove dispenser from inside door's hinges by using slotted screwdriver. Push and remove the dispenser.

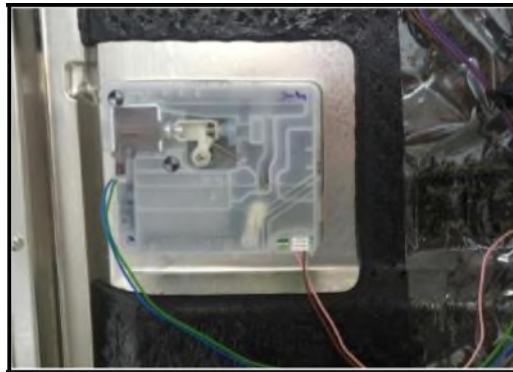

Door Inside

- a) Remove side panels.
- b) Remove Built-in Hinge Spring.

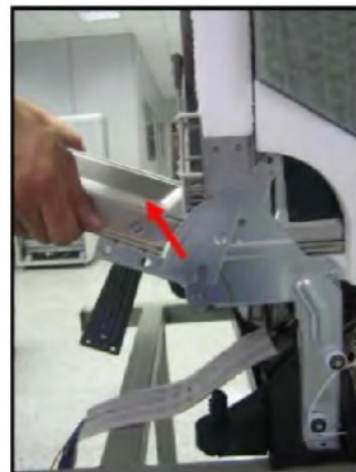

- c) Pull the door inside up as It is shown in the picture.

- d) Remove two screws that fix hinge movement sheet iron to the door inside.



Air - break

- a) Remove the left side panel of the machine.
- b) Open machine's door
- c) Rotate counterclockwise air-break nut and remove it.
- d) Remove air-break's connections with salt cap as it is shown in the picture. (be careful about plastic hinges)





Hose connection plastic

- a) Remove left side panel.

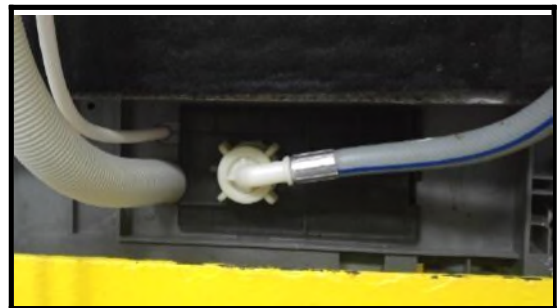

- b) By using flat tip screwdriver remove hose connection plastic's hinge from the basement as it shown in the picture



- c) Push the hose connection plastic.

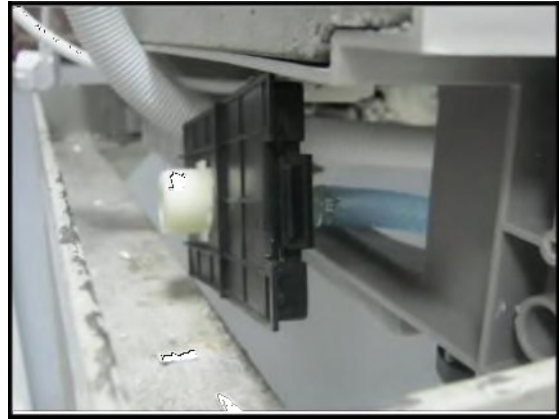

Warning: If you do not obey instructions while disassembly of the hose connection plastic it can be broken.

Power cord

- a) Remove hose connection plastic.
- b) Remove the lower cover.
- c) Remove the wires that is between power cord and parasite filter.
- d) Remove the power cord.



Regeneration valve

- a) Remove plastic kick plate and kick plate iron sheet.
- b) Remove the wires
- c) To remove regeneration Value rotate counterclockwise and pull it as it is shown in the picture.

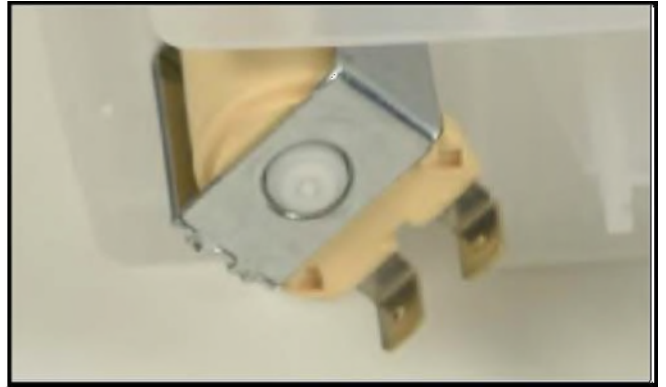
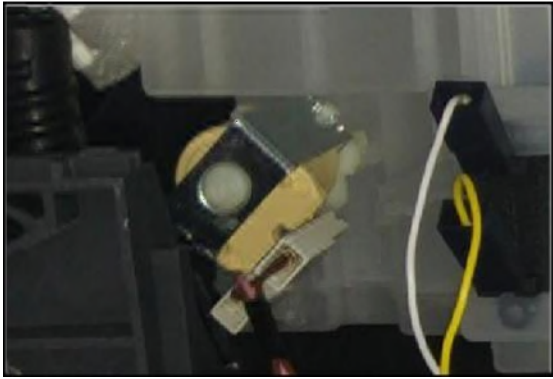

Drain pump

- a) Remove plastic kick plate and kick plate iron sheet
- b) Remove the wires.
- c) To remove the drain pump that fixes to the sump, rotate it in the direction of counter clockwise and pull.



Circulation pump

- a) Remove lower cover from the places and measure the component.

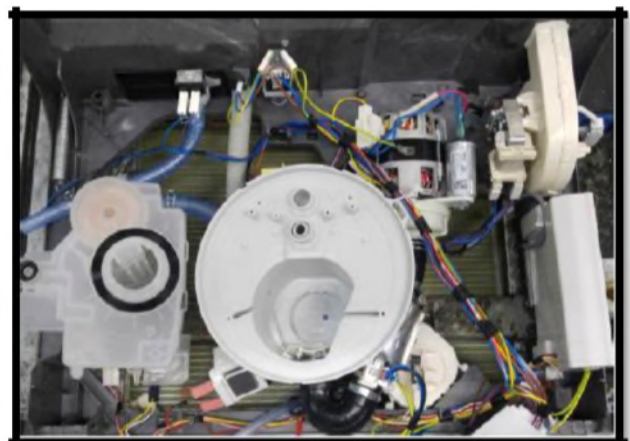
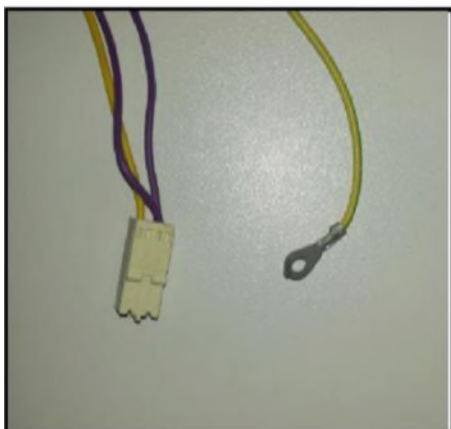

Water softener

- a) To remove salt cup cover, rotate it in the direction of counter clockwise
- b) Remove left side panel.
- c) Derach the connections which are between water softener and air-break.
- d) Remove lower cover.
- e) Remove the hose that is between sump and salt camp.

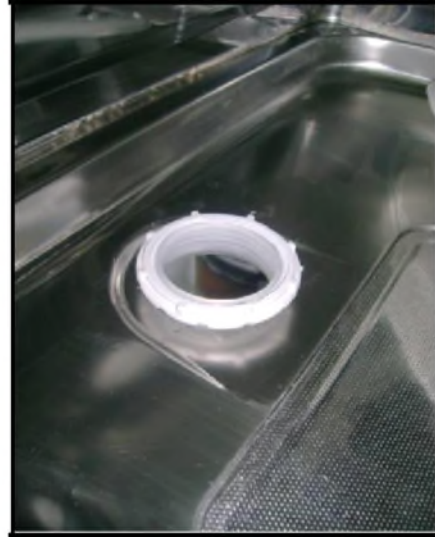

Parasite filter

- a) Remove lower cover.
- b) Remove one screw fixing parasite filter.
- c) Remove wires.
- d) Push parasite filter and remove it.



Floater

- a) Remove lower cover.
- b) Remove two screws that fix floater as it is shown in the picture.
- c) Remove the two floater hoses.
- d) Remove the wire that is connected to the floater.



Water Inlet valve

- a) Remove lower cover.
- b) Remove the wire that is connected to the water inlet valve.
- c) Remove the clamp that connects water inlet valve and air-break as it is shown in the picture



To remove water inlet valve pull it back as it is shown in the direction of picture then release water inlet valve from the pins that is connecte to and rotate it in the direction of counter clockwise.

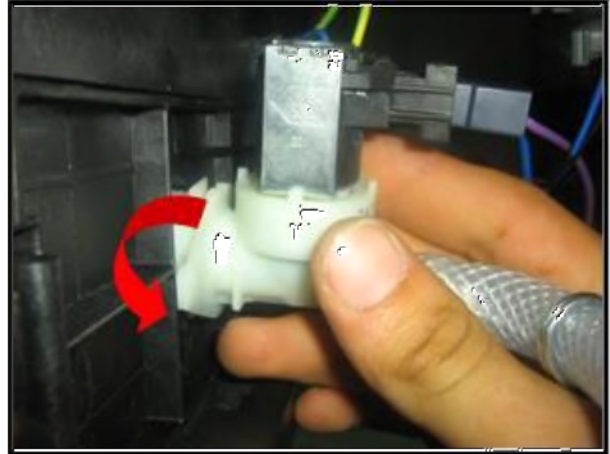
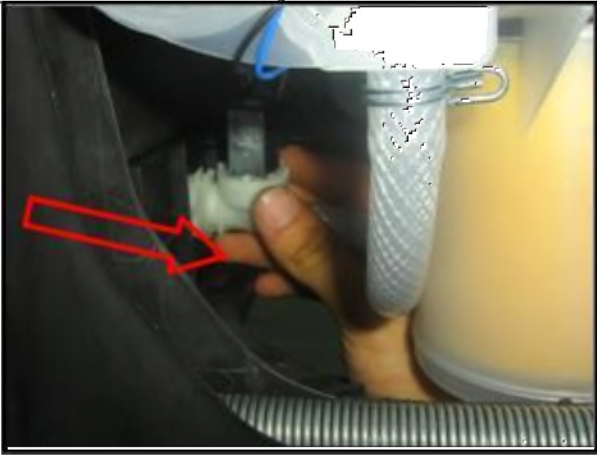

Draining Hose

- a) Remove the hose connection plastic.
- b) Remove lower cover.
- c) Remove the clamp that fixes draining hose to the sump
- d) Remove draining hose



Micro and Metal Filters

- a) Open the door.
- b) Remove lower basket
- c) To remove microfilter group rotate them in the direction of counter clockwise and pull them up as it is shown in the picture
- d) To remove microfilter group (course filter and micro filter) pull them as it is shown in the picture.
- e) To remove the metal filter pull it up as it shown in the picture.

