

N = neutre = -  
L = Phase = +

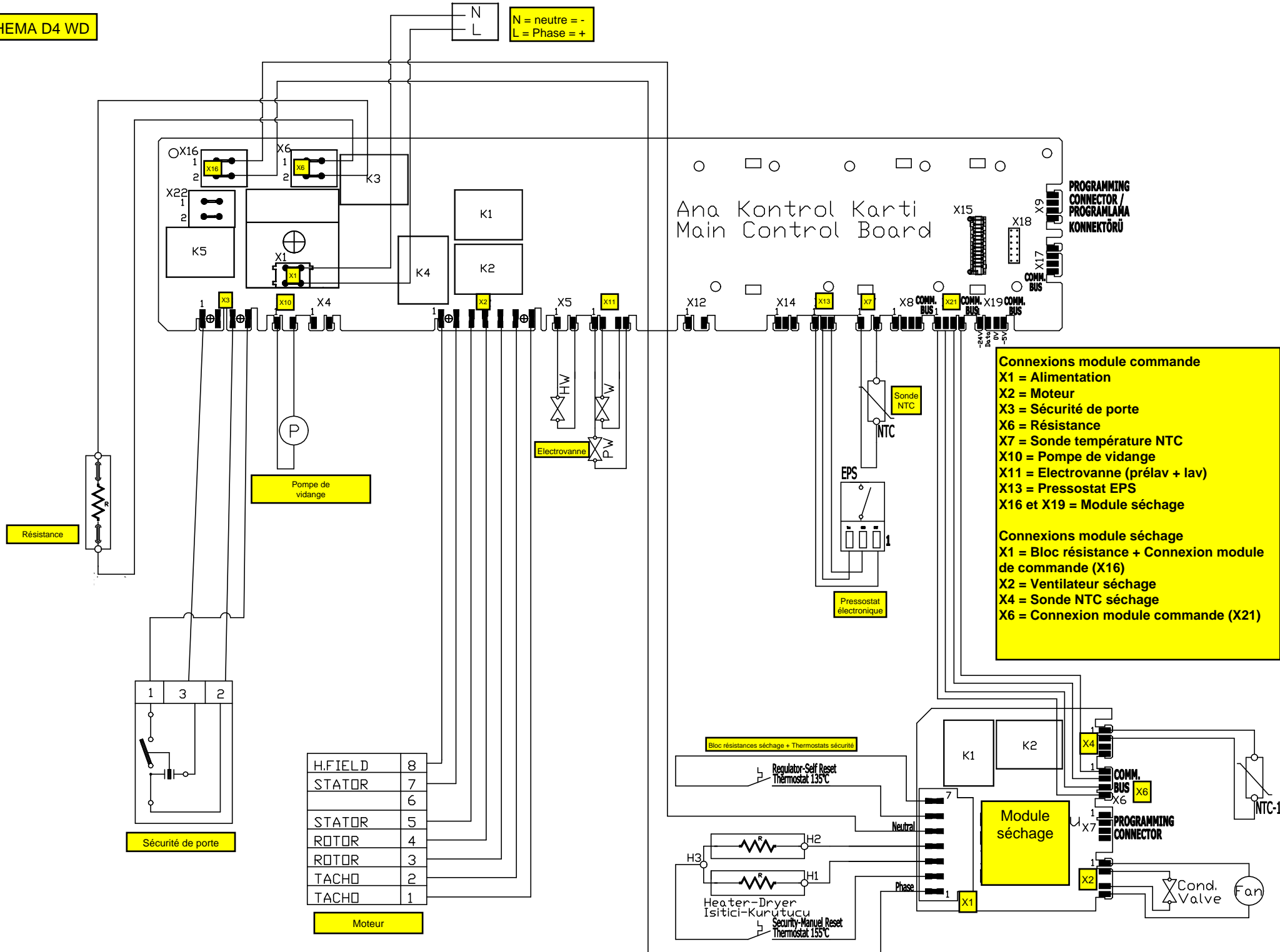

- Connexions module commande**
- X1 = Alimentation
  - X2 = Moteur
  - X3 = Sécurité de porte
  - X6 = Résistance
  - X7 = Sonde température NTC
  - X10 = Pompe de vidange
  - X11 = Electrovanne (prélav + lav)
  - X13 = Pressostat EPS
  - X16 et X19 = Module séchage
- Connexions module séchage**
- X1 = Bloc résistance + Connexion module de commande (X16)
  - X2 = Ventilateur séchage
  - X4 = Sonde NTC séchage
  - X6 = Connexion module commande (X21)

H.FIELD	8
STATOR	7
	6
STATOR	5
ROTOR	4
ROTOR	3
TACHO	2
TACHO	1

Moteur

Module séchage

PROGRAMMING CONNECTOR / PROGRAMLAMA KONNEKTÖRÜ

Ana Kontrol Kartı  
Main Control Board

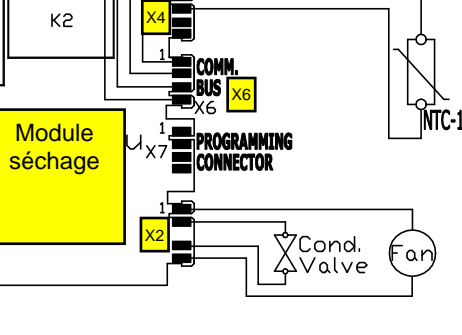



Service Manual  
for  
D4 Series



# Table of Contents

1. Safety Precautions .....	4
2. Specifications .....	5
3. Control Panel and Acronyms.....	6
4. Test Mode .....	7
4.1. Autotest.....	7
5. Service Mode .....	9
5.1. Service Autotest .....	9
5.2. Failure Codes.....	10
6. Critical Torque Values .....	10
7. Component Specifications .....	11
7.1. Drain Pump.....	11
7.2. Heater.....	12
7.3. Washer NTC.....	13
7.4. Valve.....	14
7.5. Electronic Pressure Sensor (EPS)* .....	15
7.6. Motor .....	16
7.8. Door Lock* .....	17
8. Wiring Diagram* .....	21
9. Troubleshooting.....	22

## 1. Safety Precautions



### Important:

This service information is designed for experienced repair technicians only and is not designed for use by the general public. It does not contain warnings or cautions to advise non-technical individuals of potential dangers in attempting to service a product. Products powered by electricity should be serviced or repaired only by experienced professional technicians. Any attempt to service or repair the product or products dealt with in this service information by anyone else could result in serious injury or death.



### Warning:

Before any disassembly/repair operation make sure appliance is unplugged water tap is closed and heating elements are cooled down. There is electrical shock, burning and flood risk.



### Warning:

Please replace whole cable group even in case there is any minor failure with cables / terminals / sockets. Never try to repair nor to solder cable group. It may cause smoke, ignition and there is major risk of electrical shock.



### Important:

Always use insulator gloves to prevent injury by metal edges or to prevent electrical shock during electrical tests.

Work with uniforms having long sleeves to protect your arms from metal edges.







Always use original spare parts. You may harm appliance, end user, environment or yourself using untested and unapproved 3rd party spare parts.

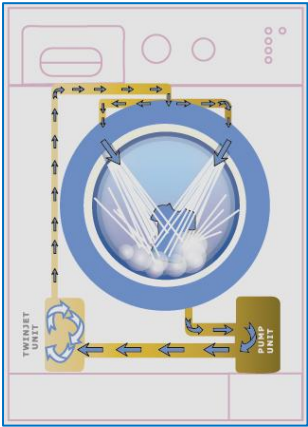

Use right tools to prevent any wear or damage to components during assembly/disassembly.

## 2. Specifications

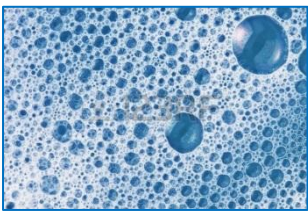
Here you will find descriptions of generic specifications for the range specified for this service manual. Please refer to product fiche and user manual for detailed technical specifications.

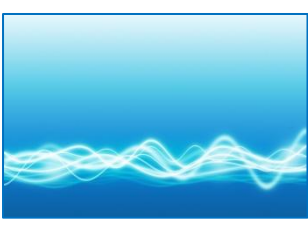
	<p><b>*Twinjet System:</b></p> <p>Twinjet system is designed to obtain a better washing performance by directly injecting water with detergent using a recirculation system and two nozzles connected to it. With twinjet system, water consumption is decreased by 30%, energy consumption is decreased by 10% and washing time is decreased by 15%</p> <p>Twinjet system is valid for all programs except spin and drain mode. The system does not function during Water inlet, heating, spinning, drain phases.</p> <p>Even with a large load of 8 kg. the washing machine will have the minimum energy consumption by the help of Twinjet system.</p> <p>Washing machines with Twinjet system are very environment-friendly by having maximum washing performance with minimum water consumption.</p>
	<p><b>Eco-Logic System:</b></p> <p>Half load detection system, thus using less water and power accordingly. This system is available for cotton programs only.</p>
	<p><b>Foam Protection System:</b></p> <p>Foam Protection System is a safety algorithm that interrupts normal program flow and reduces foam level by taking water and draining. This algorithm protects machine and environment avoiding over foaming inside tub in case any customer misuse such as detergent overdose or use of foamy cleaning agents.</p>
	<p><b>Overflow Protection System:</b></p> <p>Overflow protection is another safety algorithm in case of a flood risk. If there is more water in tub than expected by algorithm, it will start to the drain routine giving E04 failure code. For example this may happen in case of a valve failure and the machine constantly takes water. This algorithm will keep drain routine, keeps water leveled and protects environment and machine avoiding any flood risk.</p>
	<p><b>Unbalanced Load Detection and Control System:</b></p> <p>Unbalance Control System is another safety algorithm that protects the machine and environment avoiding machine movement due to vibration during spinning profile. The algorithm tries to balance load by a special balancing agitation, postponing spin profile till it is balanced. This avoids spinning while load is unbalanced and prevents any possible physical harm both to the appliance and to surroundings.</p>

### 3. Control Panel and Acronyms

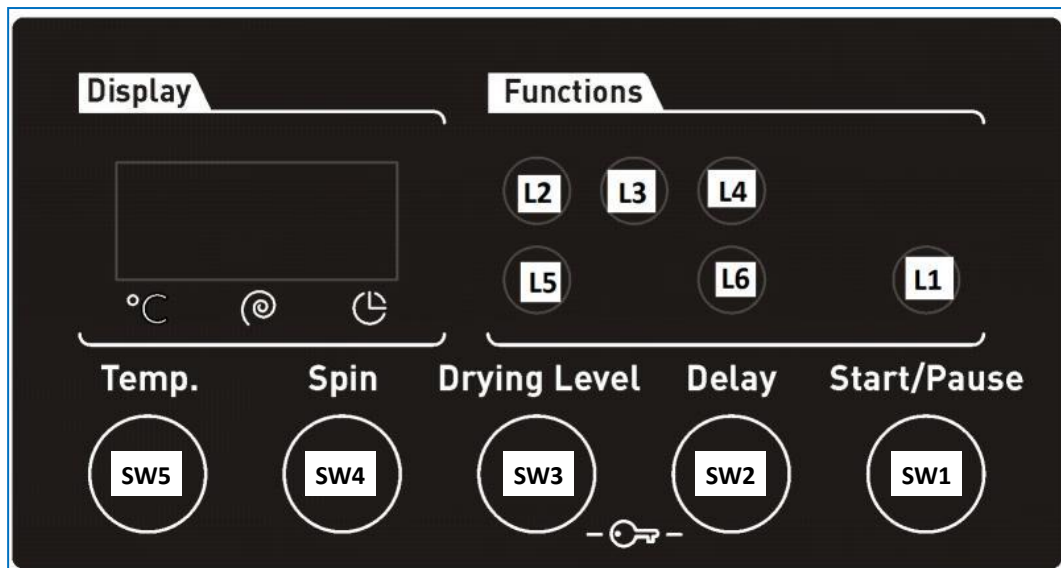
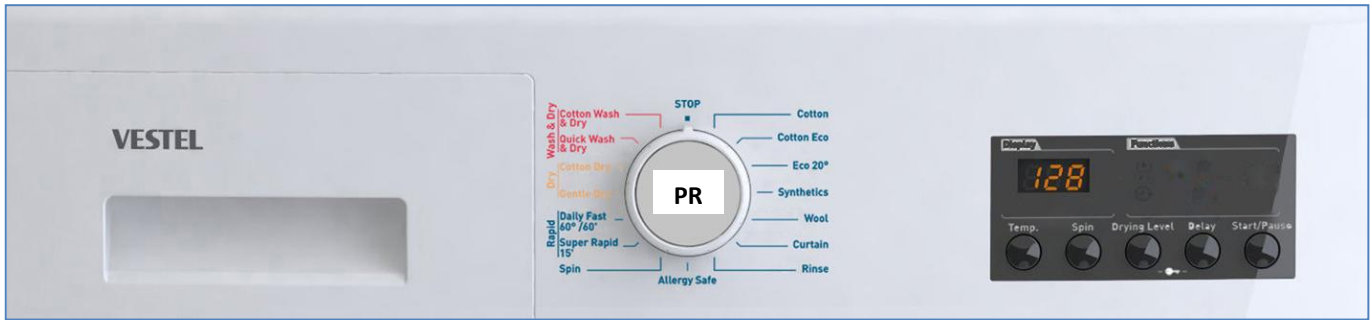

PR	Program selector 16 programs including off position
SW1	Switch 1, Start / Pause
SW2	Switch 2, Option 1 (Delay Timer)
SW3	Switch 3, Option 2 (Drying Level)
SW4	Switch 4, Spin Speed Selection
SW5	Switch 5, Temperature Selection
L1	LED 1, Start/Pause LED
L2	LED 2, Drying Level 1 LED
L3	LED 3, Drying Level 2 LED
L4	LED 4, Drying Level 3 LED
L5	LED 5, Drying Level Option LED
L6	LED 6, Delay Time LED

## 4. Test Mode

### 4.1. Autotest

1. Press and hold SW5.



2. While pressing SW5, turn PR to 1<sup>st</sup> position (Cotton). Wait 3 seconds and release SW5. During test "AU" is visualized on display.



3. When autotest is finished, END screen is visualized.



#### 4.1.1. Autotest Steps

Autotest follows a predefined flowchart in order. Unlike service autotest, autotest automatically skips to next step upon completing one. The steps of the test are as follows:

Step1:

The drain pump is checked.

Step2:

Motor ramps to max spin speed while valves are activated in order.

Step3:

Motor stops, both valves are activated simultaneously.

Step4:

The motor turns to right. Also, dryer valve is activated.

Step5:

The motor turns to left.

Step6:

Both valves are activated. (Water intake for heating)

Step7:

Washer NTC is checked.

Step8:

Washer Heater is checked.

Step9:

Dryer resistance I and I&II are checked.

Step10:

Dryer NTC is checked for 2sec.

Step11:

Fan is checked.

In case of no failure test ends after this step and "End" is displayed. In case of an error detection EXX and error definition will pop up on display. (where XX is the error number 1 to 10 )

Please see following autotest chart for details.

AUTOTEST	
Time in seconds (to be adjusted)	5 10 15 20 25 30 35 40 45 50 55 60 65 70 75 80 85 90 95 100
Entering autotest	0-10
Changing power to 220 50Hz	10-15
Main Voltage 50 Hz	15-100
Door Lock Powered (Depends on door lock)	15-100
Pump	20-100
EPS measurement	20-25
Motor Ramp to max spin (max. is 20 sec.)	20-40
EV1 (flowrate dependent of washer)	20-45
EV2 (flowrate dependent of washer)	25-35
Dryer valve	45-55
Time until motor is stopped (Depends on the motor stop time)	40-45
Motor Preferred Run (Direction to Right)	45-55
Motor Inverse Run (Direction to Left)	55-65
EV1 + EV2 valves up to first level frequency (Depends on the water level)	65-75
Washer NTC check	70-75
Washer heater resistance	75-85
Dryer resistance I	80-85
Dryer resistance I + II	85-90
Dryer NTC	90-95
Fan	95-100
End Visualization	100

Washer Ntc detection : Software will detect NTC's resistance value and will check if the temperature is between  $5^{\circ}\text{C} < T_{\text{detected}} < 40^{\circ}\text{C}$ . If it is inside the range, heating step will be done. If temperature value is outside the range, then it means NTC is detecting the temperature in a wrong way and heating step will be skipped. Additionally if NTC connector disconnected it should shows NTC failure code(E05) on display.

EPS measurement: It checks the EPS and if it OK, it continues the autotest; if it is NOK then cancel the Autotest and go to the selection mode. Also if any frequency can not be detected, then it means there is problem with connexion or EPS, so it gives E10 which is EPS error and cancels the autotest & goes to the selection mode.

**Dryer Ntc detection** : Software will detect NTC's resistance value and will check if the temperature is between  $0^{\circ}\text{C} < T_{\text{detected}} < 50^{\circ}\text{C}$ . If it is inside the range, heating step will be done.



## 5. Service Mode

### 5.1. Service Autotest

1. Press and hold SW4.



2. While pressing SW4, turn PR to 1<sup>st</sup> position (Cotton). Wait 3 seconds and release SW4. Step 1 of service autotest will start. During test "SAU" is visualized on display. Please see details about steps in right column.



3. When autotest is finished, END screen is visualized.



#### 5.1.1. Service Autotest Steps

If you turn knob position to other program between 1st to 3<sup>rd</sup> it will skip current test and start the selected one. It is recommended not to skip any steps for a detailed checkup. Unlike autotest, service autotest starts next test step manually by rotating program selection knob.

##### Step1:

There will be a certain amount of water intake and then washer heater is activated for 8 minutes. Washer NTC values are checked in this period. In case of a washer heater/NTC failure, it pops up E05 error displaying "E05" on SW3.

At the end of heating, "SAU" visualization should make slow blink to indicate that the step is over. You can turn program knob to 2<sup>nd</sup> position to continue with step2.

\*During this step if EPS detects high water level, overflow algorithm is applied and E04 is released.

##### Step2:

Drain pump is activated; in case of a pump failure it pops up E03 error.

At the end of pump activation, "SAU" visualization should make slow blink to indicate that the step is over. You can turn program knob to 3<sup>rd</sup> position to continue with step3.

##### Step3:

Dryer Heater I and fan is activated. After 3 mins if there will be no temperature change ( $\Delta T < 10^{\circ}\text{C}$ ), it will release E14 failure.

If temperature increases accordingly ( $\Delta T > 10^{\circ}\text{C}$ ), "SAU" visualization should make slow blink to indicate that the step is over. You can turn program knob to 4th position to continue with step4.

##### Step4:

Dryer Heater II and fan is activated. After 3 mins if there will be no temperature change ( $\Delta T < 10^{\circ}\text{C}$ ), it will release E14 failure.

If temperature increases accordingly ( $\Delta T > 10^{\circ}\text{C}$ ), "SAU" visualization should make slow blink to indicate that the step is over. You can turn program knob to 5th position to continue with step5.

##### Step5:

Rapid 15' program algorithms is run to test all washing components, the only difference is error codes are displayed which normally are not displayed to end user.

If no error found in test program "SAU" visualization should make slow blink to indicate that the step is over. You can turn program knob to 6th position to continue with step6.

##### Step6:

A 5 mins drying program is run to test all drying components.

If case of no error service autotest ends and "End" is displayed.

\*If user changes the selector position, machine will do what is defined for the new selected position.

## 5.2. Failure Codes

Error Indication	Error Number	Indication in UI	Indication in SI
Door/Door Lock Failure	E01	A	A
Lack of water	E02	A	A
Pump failure	E03	A	A
Overflow	E04	A	A
NTC or Heater Failure	E05	NA	A
Motor Failure	E06	NA	A
Electronic Pressure Sensor	E10	NA	A
Dryer Board Connection Failure	E11	NA	A
Dryer Thermostat Failure	E14	NA	A
Dryer NTC Failure	E18	NA	A

## 6. Critical Torque Values

	Assembly Location	Bolt/Nut/Screw	Torque Min. (Nm)	Torque Nom. (Nm)	Torque Max. (Nm)	Air Pressure Wrench Speed (rpm)
*	Transport Screw Assembly	Transport Screws	6.50	6.50	7.00	1000
*	Motor Assembly	Motor Screws	6.00	6.50	7.50	800
*	Front Concrete Weight - Front Tub Assembly	Front Counterweight Screws	14.00	14.50	14.75	600
*	Upper Counter Weight Assembly	Upper Counterweight Screws	25.00	27.50	30.00	440
*	Pulley – Drive Shaft – Washing Group Assembly	Pulley – Drive Shaft Assembly Bolt	39.50	40.00	40.50	440
*	Washer Heater Assembly	Heater Assembly Nut	3.85	4.00	4.00	970

The bolts/nuts above are important for product safety purposes. Please tighten screw, bolts and nuts according to the torque values given in table above.

## 7. Component Specifications

### 7.1. Drain Pump

Drain pump is both a mechanical and electrical component which is used to drain water inside the washing machine. It has an synchronous motor inside. For better performance maintenance, pump filter should be cleaned regularly.



Drain pump

#### *Technical features*

Nominal voltage	220-240 V	Resistor (coil)	125 $\Omega$ ( $\pm 5\%$ )
Nominal current	0.28 A ( $\pm 10\%$ )	Water flow	17 L/min(to 1 m height)
Nominal power	30 W ( $\pm 20\%$ )	Thermal protector	YES
Frequency	50 Hz		

#### *Testing component*

Check the resistance value on the component with multimeter as shown below.  
Resistance value should be between 125  $\Omega$  ( $\pm 5\%$ )



## 7.2. Heater

Heating element (Resistance) is a component which is designed to regulate temperature of water inside the drum. It has three connections: Phase, notral and ground connections.



Resistance

### *Technical features*

Heater type	Tubular heating element with NTC – sensor	Nominal power	2000 W $\pm$ 5%
Nominal voltage	230 V	Resistance	26.4 $\Omega$ $\pm$ 5%
		Thermal fuse	2 sided

### *Testing component*

Check the resistance value on the component with multimeter as shown below.  
Resistance value should be between 26.4  $\Omega$   $\pm$ 5%



### 7.3. Washer NTC

The component which sends signals to PCB about the water temperature inside the tub. The resistance value of the NTC decreases as the temperature increases.



NTC

#### Technical features

Temp. (°C)	R min (kΩ)	R max (kΩ)
-10	54.9	62.6
-5	43.0	48.6
0	33.9	38.1
5	27.0	30.1
10	21.6	23.9
15	17.4	19.1
20	14.1	15.4
25	11.5	12.5
30	9.4	10.2
35	7.8	8.3
40	6.4	6.9
45	5.4	5.7

Temp. (°C)	R min (kΩ)	R max (kΩ)
50	4.5	4.7
55	3.8	3.9
60	3.2	3.3
65	2.7	2.8
70	2.3	2.4
75	1.9	2.0
80	1.7	1.8
85	1.4	1.5
90	1.2	1.3
95	1.1	1.1
100	0.9	1.0

NTC Resistance vs. NTC Temperature

#### Testing component

Check the resistance value on the component with multimeter as shown below.



## 7.4. Valve

Valve is an electrical and mechanical component which is designed to take water from network system into the washing machine. It is operated by PCB card.

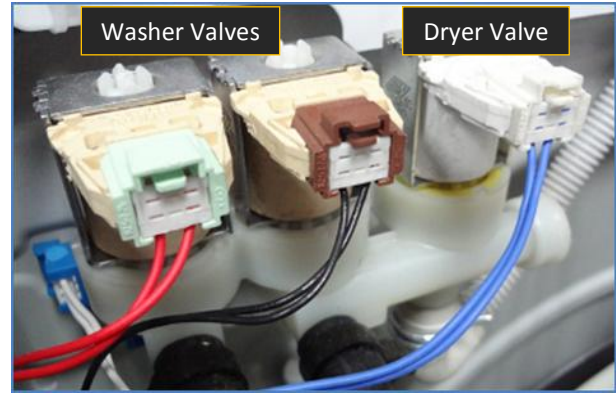

Valves

### Technical features

Nominal voltage 220-240 V  
Frequency 50-60 Hz

Flow rate (washer valves) 7 L/min ( $\pm 15\%$ )  
Flow rate (dryer valve) 1.2 L/min ( $\pm 15\%$ )  
Operating water pressure 1-10 bar

### Testing component

Check the resistance value on the component with multimeter as shown below. Washer valves' water flow rate should be 7 L/min  $\pm 15\%$ . Dryer valve's water flow rate should be 1.2 L/min  $\pm 15\%$ . Washer valves' coil resistance values should be  $3750\Omega \pm 10\%$ . Dryer valve's coil resistance value should be  $5190\Omega \pm 10\%$ .



### 7.5. Electronic Pressure Sensor (EPS)\*

Electromagnetic field occurs due to movement of pressurized membrane. The coil moves vertically by nucleus due to electromagnetic field. The water level is regulated according to the frequency changes of the coil by electronic card.

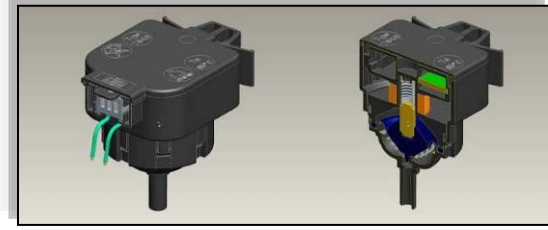

EPS

#### ***Testing component***

1. Make sure there are no laundry in washing machine, tap is connected and opened, power cord is plugged. Put no detergent in drawer.
2. Bring program knob to position 1 (Cotton 90°C program)
3. Press start button.
4. Wait for water intake step to finish. You can recognise it by listening the water sound or slightly opening and observing detergent drawer.
5. As soon as water intake is over turn program knob to position 0 (Off position)
6. Check water level from door glass. The water level should be just below door glass as seen in the picture below: (There is a %10 tolerance with this level)



## 7.6. Motor

The washing machine has an asynchronous motor. It is controlled by the PCB. It is essential to check the motor for correct diagnosis and quick servicing. In the below picture, socket points on the motor is shown to measure with multimeter.

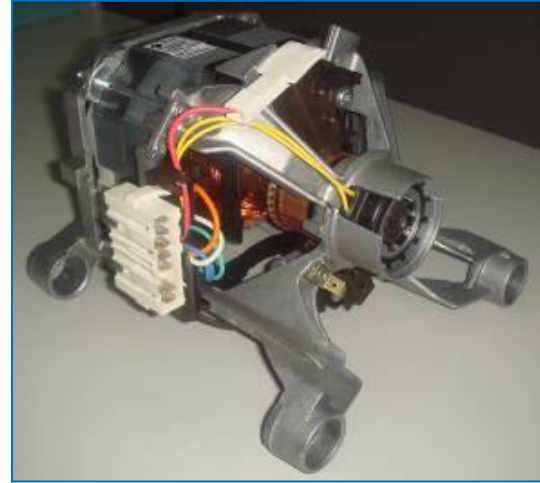

Motor

### Motor socket terminals

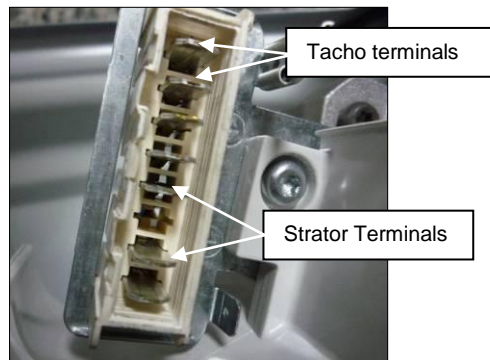

MOTOR CODE	BRAND	STATOR (FULL) $\Omega$	TACHO $\Omega$	STATOR (HALF) $\Omega$	TEMP.
32013066	ANAIMEP	1.20 $\pm$ 7%	180 $\pm$ 7%	0.55 $\pm$ 7%	20 °C



## 7.8. Door Lock\*

Door lock is activated at the beginning of the program in order to prevent the door from opening. It can be unlocked between 45 seconds to 85 seconds after the program end. This time delay is caused by the PTC which is assembled in the door lock.

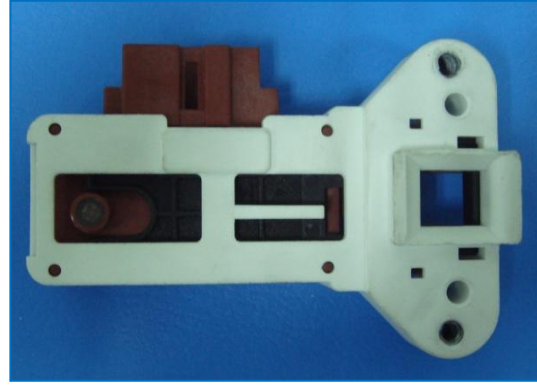

Door lock

### *Technical features*

Nominal voltage      250 V

### *Testing component*

Check the resistance value on the component with multi-meter as shown in below figures. Resistance value should be  $1000\Omega \pm 50\%$  at  $20\text{ }^{\circ}\text{C}$ .



## 7.9. Fan Group

Air pump component for drying cycle. Pumps dry cold air from condenser to dryer heater.



Fan group

### Technical features

Nominal voltage	230 V	Resistance @ 20°C	82.7Ω ±3Ω
Frequency	50 Hz	Motor speed	1300 RPM
Rated Power	34 W	Air Flow Rate	70 m <sup>3</sup> /h

### Testing component

Check the resistance value on the component with multi-meter as shown in below figures. Resistance value should be 82.7Ω ±3Ω at 20 °C.



## 7.10. Dryer Heater

Air heater unit consist of two separate resistance with nickel diffusion technology.



Dryer Heater

### Technical features

Nominal voltage	230 V
Rated power (Heater I)	750 W
Rated power (Heater II)	750 W

Resistance @ 20°C	65.5 – 72.6 Ω
-------------------	---------------

### Testing component

Check the resistance value on the component with multi-meter as shown in below figures. Resistance value should be in 65.5 – 72.6 Ω range.



### 7.11. Dryer NTC

The component which sends signals to PCB about the flowing air temperature just after dryer heater. The resistance value of the NTC decreases as the temperature increases.



Dryer NTC

#### Technical features

Temp. (°C)	R min (kΩ)	R max (kΩ)
25	19.40	20.60
30	15.56	16.67
40	10.19	11.10
50	6.82	7.54
60	4.65	5.23
70	3.25	3.70
80	2.32	2.68
90	1.69	1.97
100	1.24	1.47

Temp. (°C)	R min (kΩ)	R max (kΩ)
110	0.93	1.11
120	0.70	0.85
130	0.54	0.66
140	0.42	0.52
150	0.33	0.41
160	0.26	0.32
170	0.21	0.25
180	0.17	0.20

NTC Resistance vs. NTC Temperature

#### Testing component

Check the resistance value on the component with multi-meter as shown in below figures.

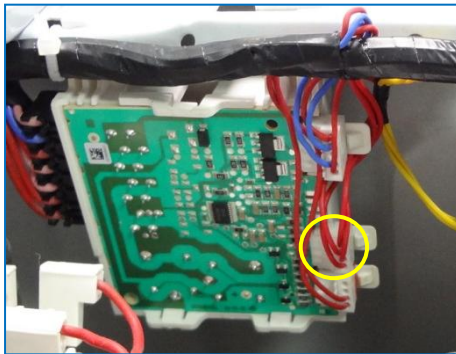

## 9. Troubleshooting

Please apply basic troubleshooting steps described in user manual. If you can not find a solution you should run service autotest and complete all steps. In case of an error encounter please follow the instructions through flowchart related with the error.

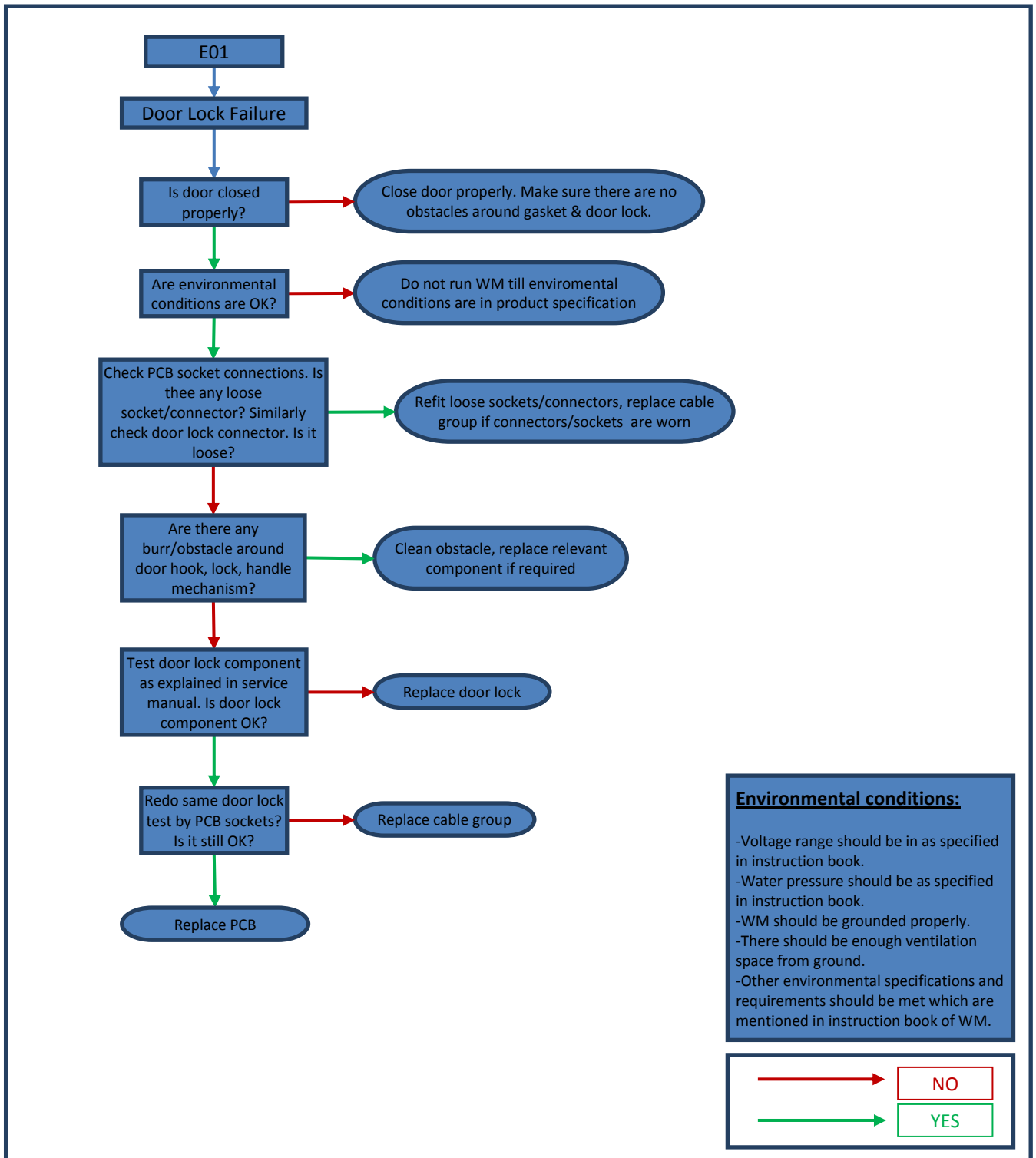

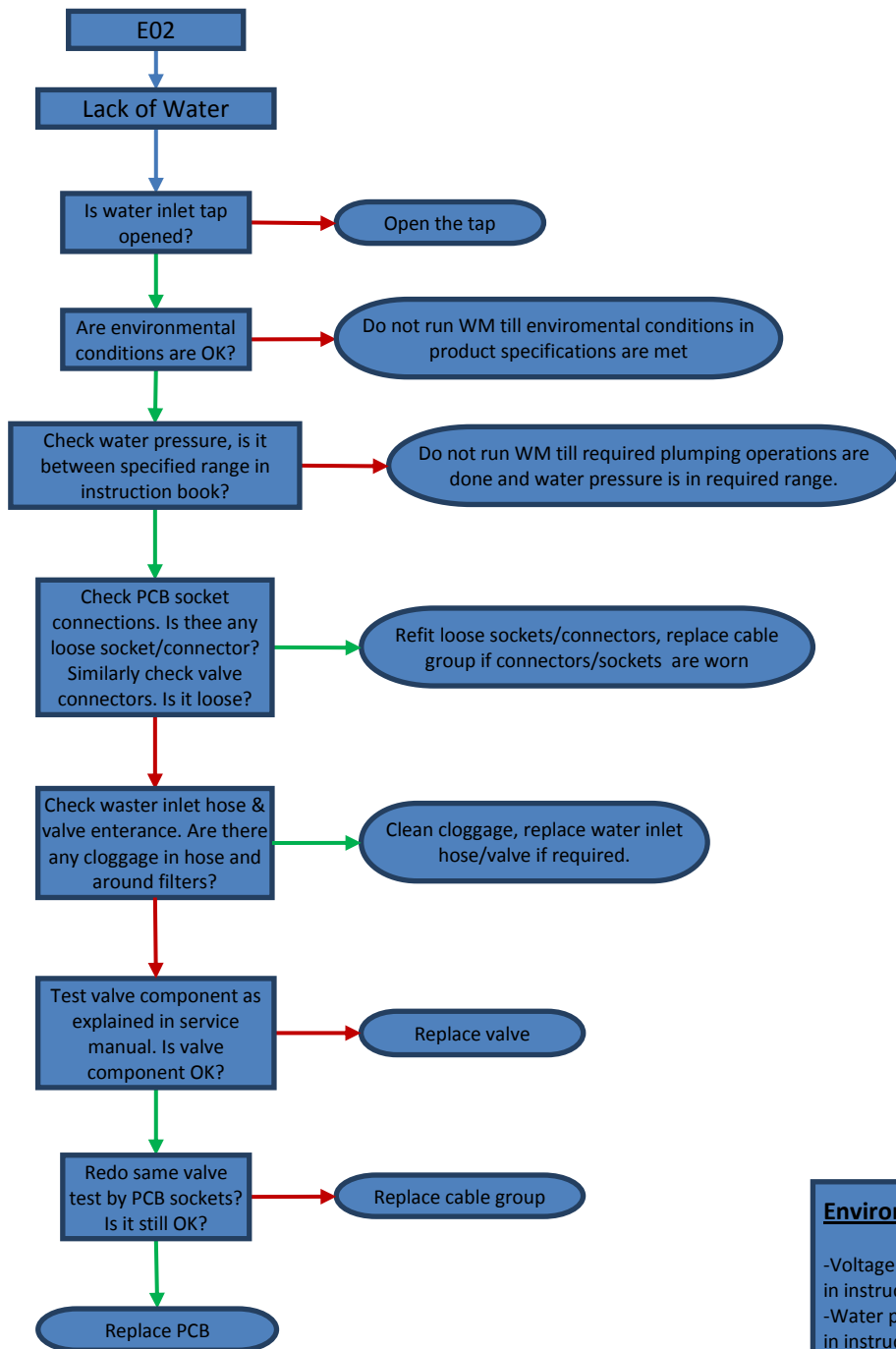

**Environmental conditions:**

- Voltage range should be in as specified in instruction book.
- Water pressure should be as specified in instruction book.
- WM should be grounded properly.
- There should be enough ventilation space from ground.
- Other environmental specifications and requirements should be met which are mentioned in instruction book of WM.

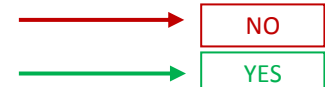

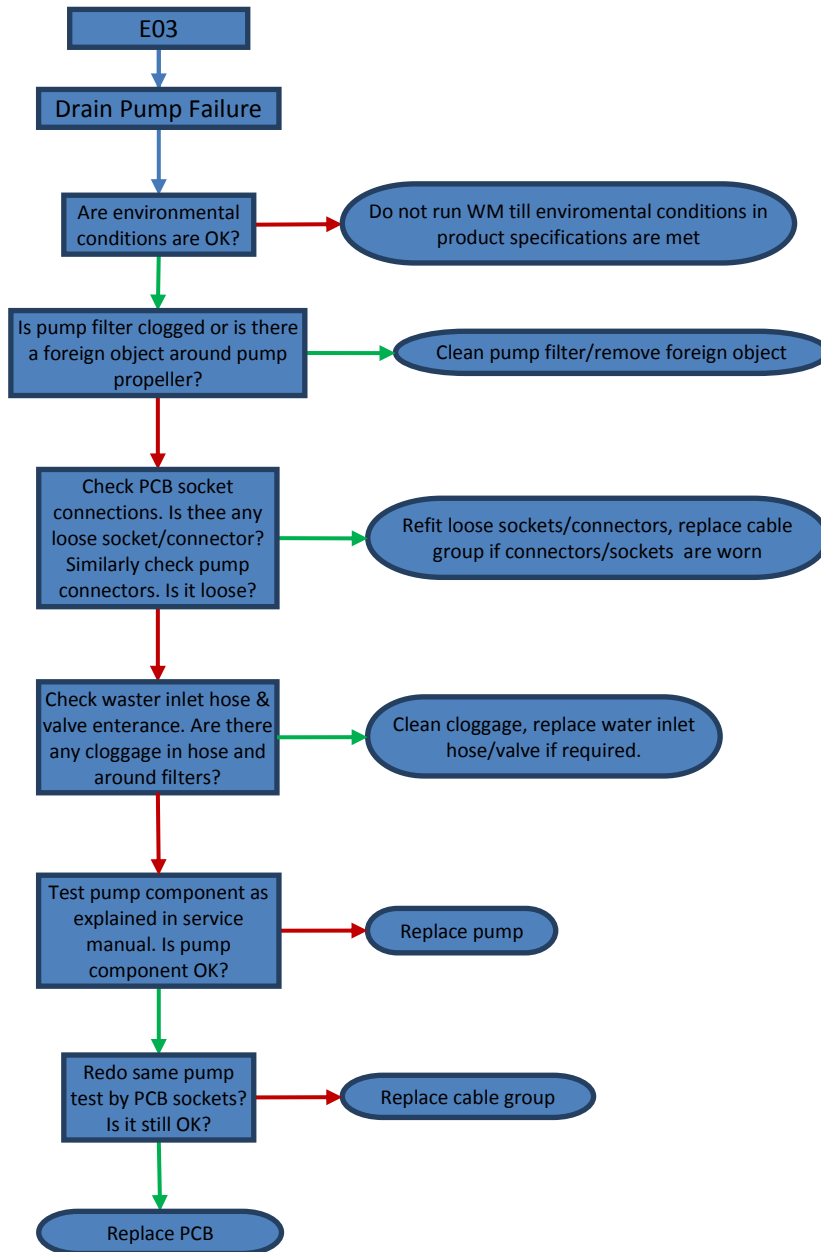

**Environmental conditions:**

- Voltage range should be in as specified in instruction book.
- Water pressure should be as specified in instruction book.
- WM should be grounded properly.
- There should be enough ventilation space from ground.
- Other environmental specifications and requirements should be met which are mentioned in instruction book of WM.

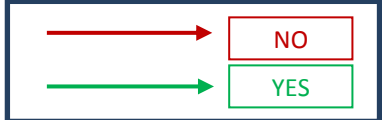

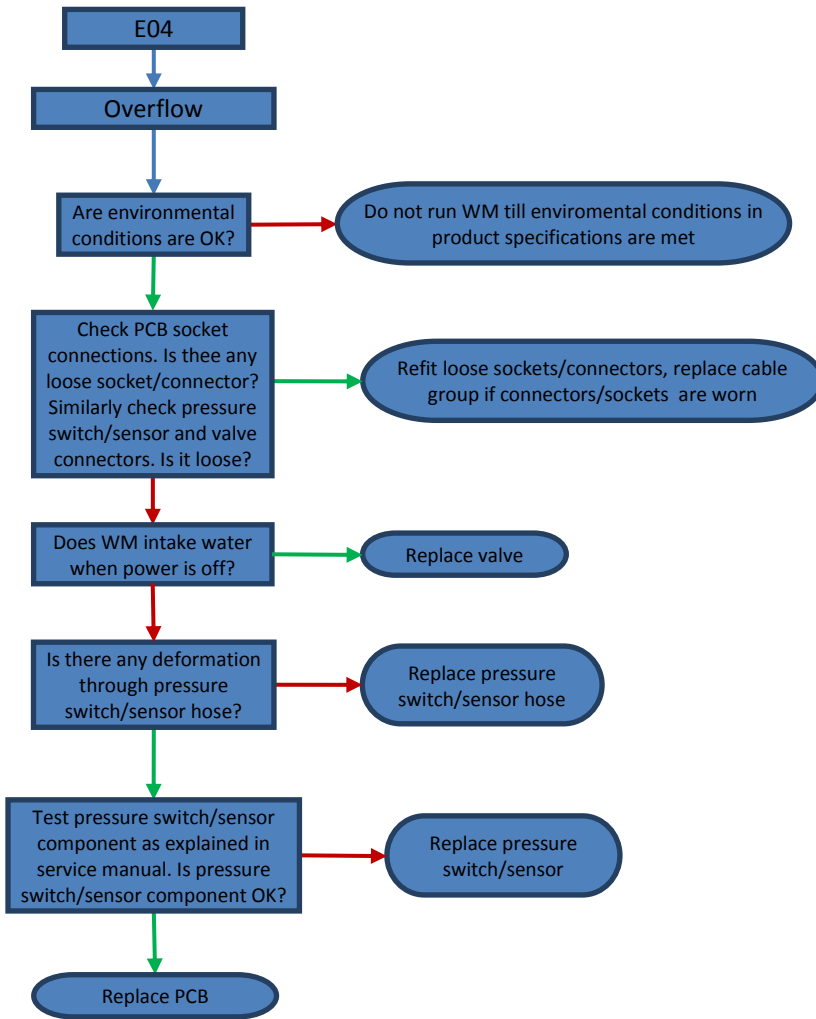

**Environmental conditions:**

- Voltage range should be in as specified in instruction book.
- Water pressure should be as specified in instruction book.
- WM should be grounded properly.
- There should be enough ventilation space from ground.
- Other environmental specifications and requirements should be met which are mentioned in instruction book of WM.

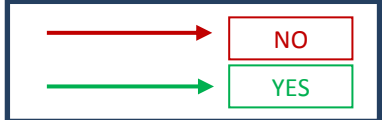



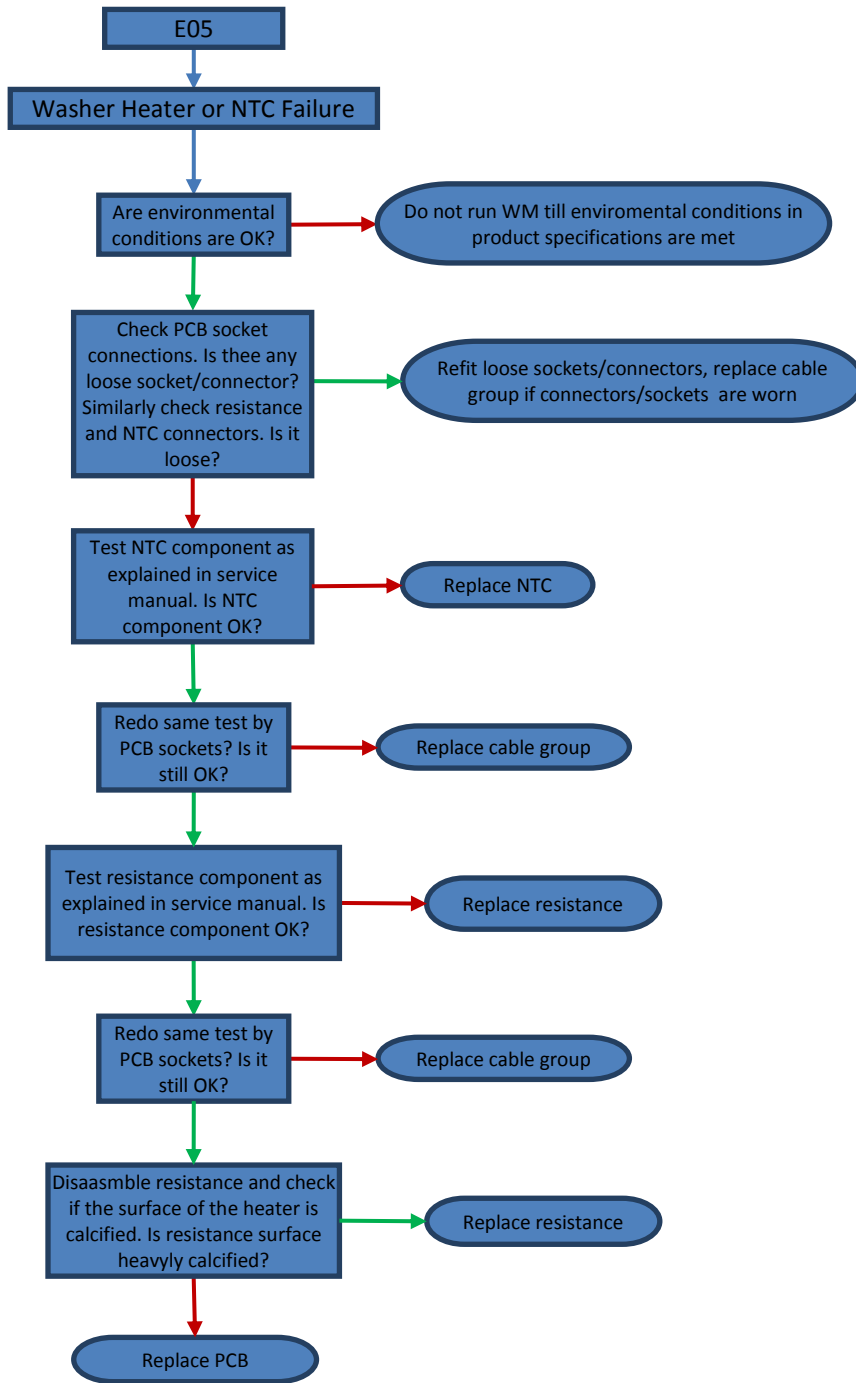

**Environmental conditions:**

- Voltage range should be in as specified in instruction book.
- Water pressure should be as specified in instruction book.
- WM should be grounded properly.
- There should be enough ventilation space from ground.
- Other environmental specifications and requirements should be met which are mentioned in instruction book of WM.

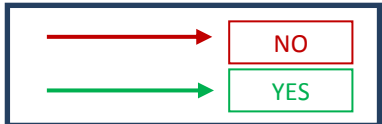

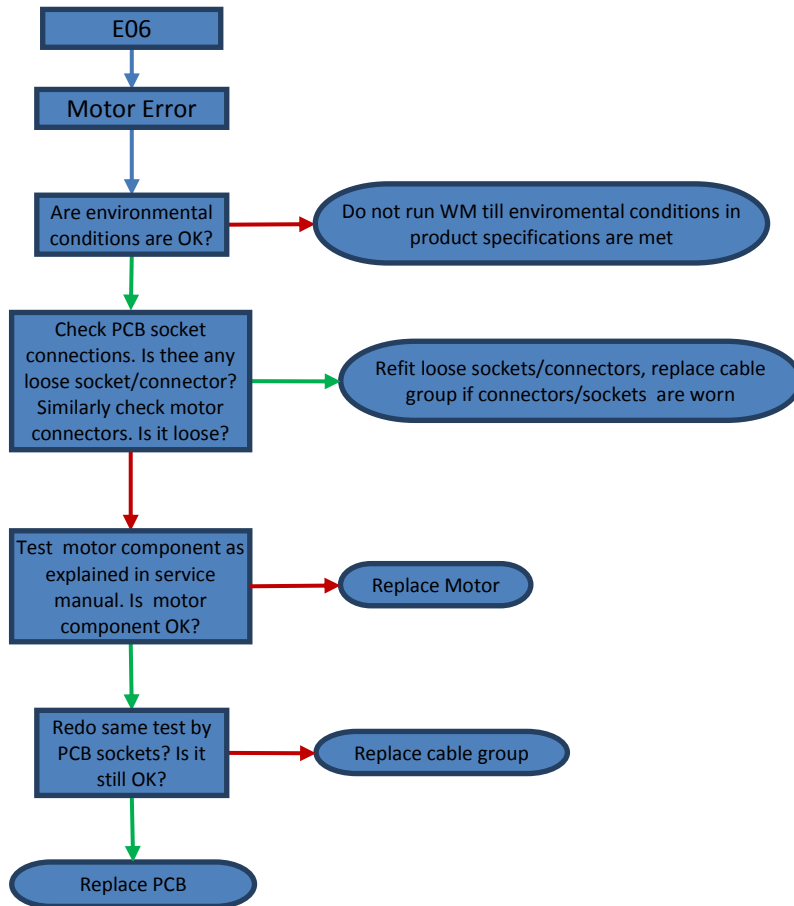

**Environmental conditions:**

- Voltage range should be in as specified in instruction book.
- Water pressure should be as specified in instruction book.
- WM should be grounded properly.
- There should be enough ventilation space from ground.
- Other environmental specifications and requirements should be met which are mentioned in instruction book of WM.

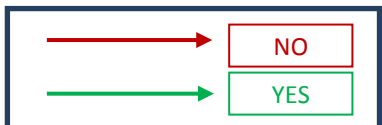

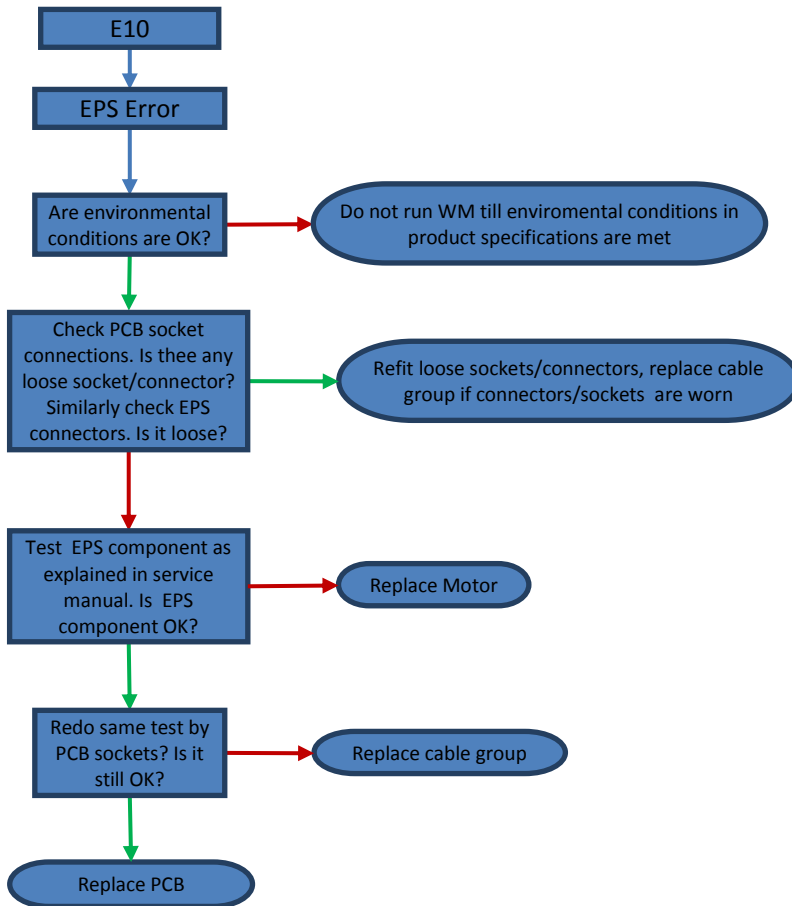

**Environmental conditions:**

- Voltage range should be in as specified in instruction book.
- Water pressure should be as specified in instruction book.
- WM should be grounded properly.
- There should be enough ventilation space from ground.
- Other environmental specifications and requirements should be met which are mentioned in instruction book of WM.

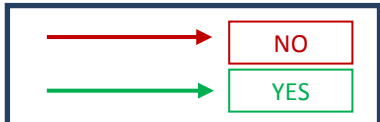

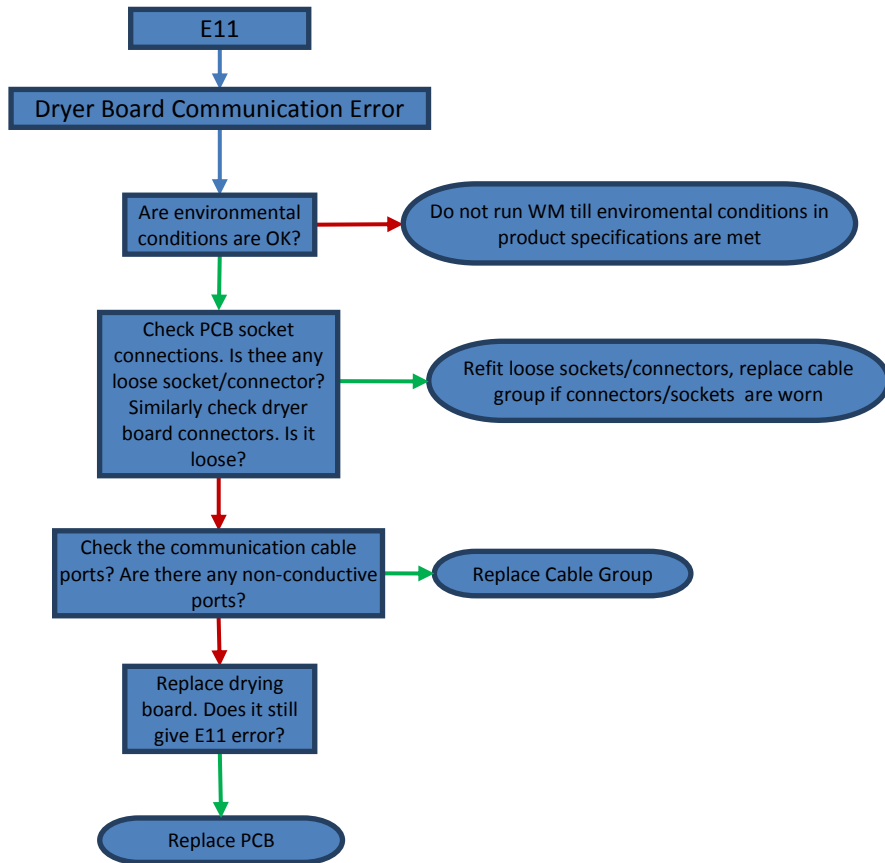

**Environmental conditions:**

- Voltage range should be in as specified in instruction book.
- Water pressure should be as specified in instruction book.
- WM should be grounded properly.
- There should be enough ventilation space from ground.
- Other environmental specifications and requirements should be met which are mentioned in instruction book of WM.

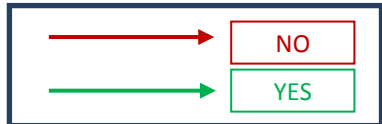

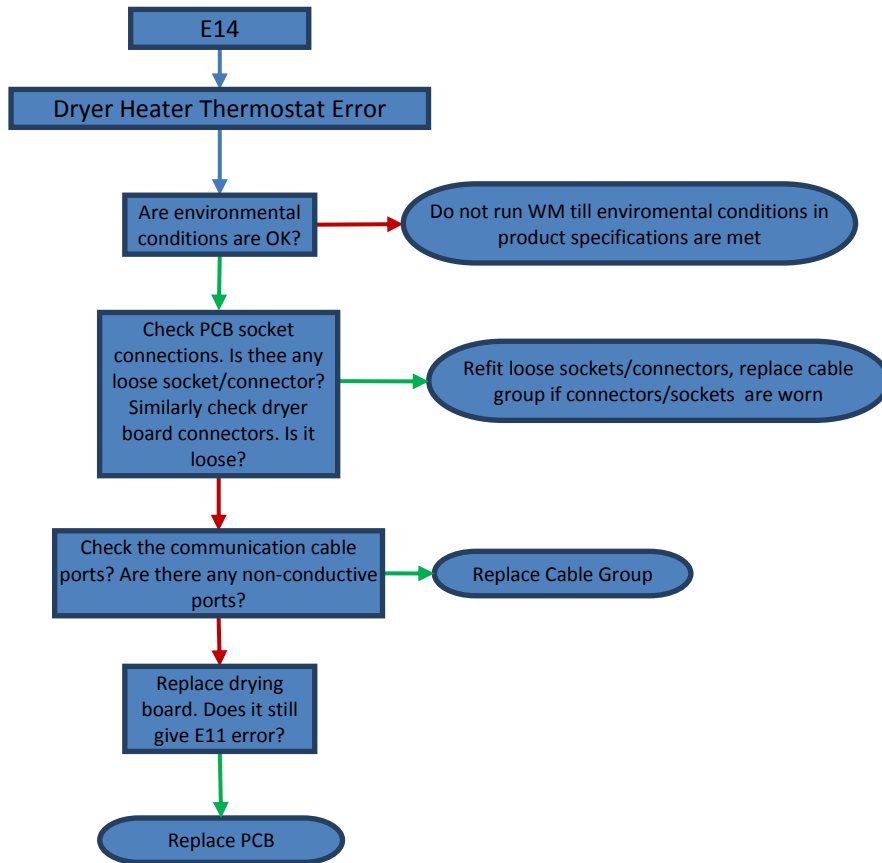

**Environmental conditions:**

- Voltage range should be in as specified in instruction book.
- Water pressure should be as specified in instruction book.
- WM should be grounded properly.
- There should be enough ventilation space from ground.
- Other environmental specifications and requirements should be met which are mentioned in instruction book of WM.

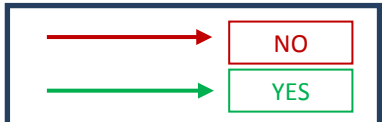

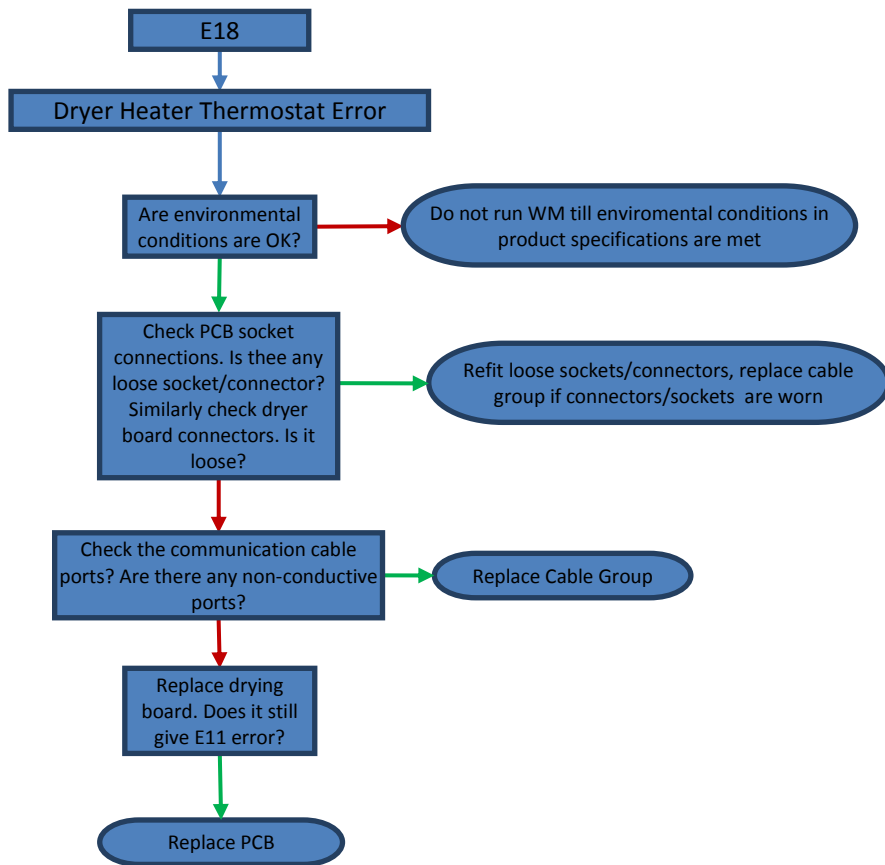

**Environmental conditions:**

- Voltage range should be in as specified in instruction book.
- Water pressure should be as specified in instruction book.
- WM should be grounded properly.
- There should be enough ventilation space from ground.
- Other environmental specifications and requirements should be met which are mentioned in instruction book of WM.

