

WQP8-9001/WQP8-9003/WQP12-9011/WQP8-9117 Circuit Diagram of MIDEA Dishwasher

CODE	NAME OF COMPONENT
CLn	Contact of timer
D/Ed	Dispenser
EV1	Solenoid
EV2	Water softener
F	Filter
IAQS	Overflow switch
IG	Power Switch
IS	Door switch
ISS	Reed switch
ITR	Thermostat of heater
LS	Power on light
LSS	Salt warning light
ML	Wash pump
MT	Timer
PO	Pressure switch
PS	Drain pump
R	Heater
S	Thermostat of pump
TS50	50°C Thermostat
TS58	58°C Thermostat
ICR	Rapid wash
PLUS	Intensive wash
ISB	Reed switch
LSB	Rinse aid warning light

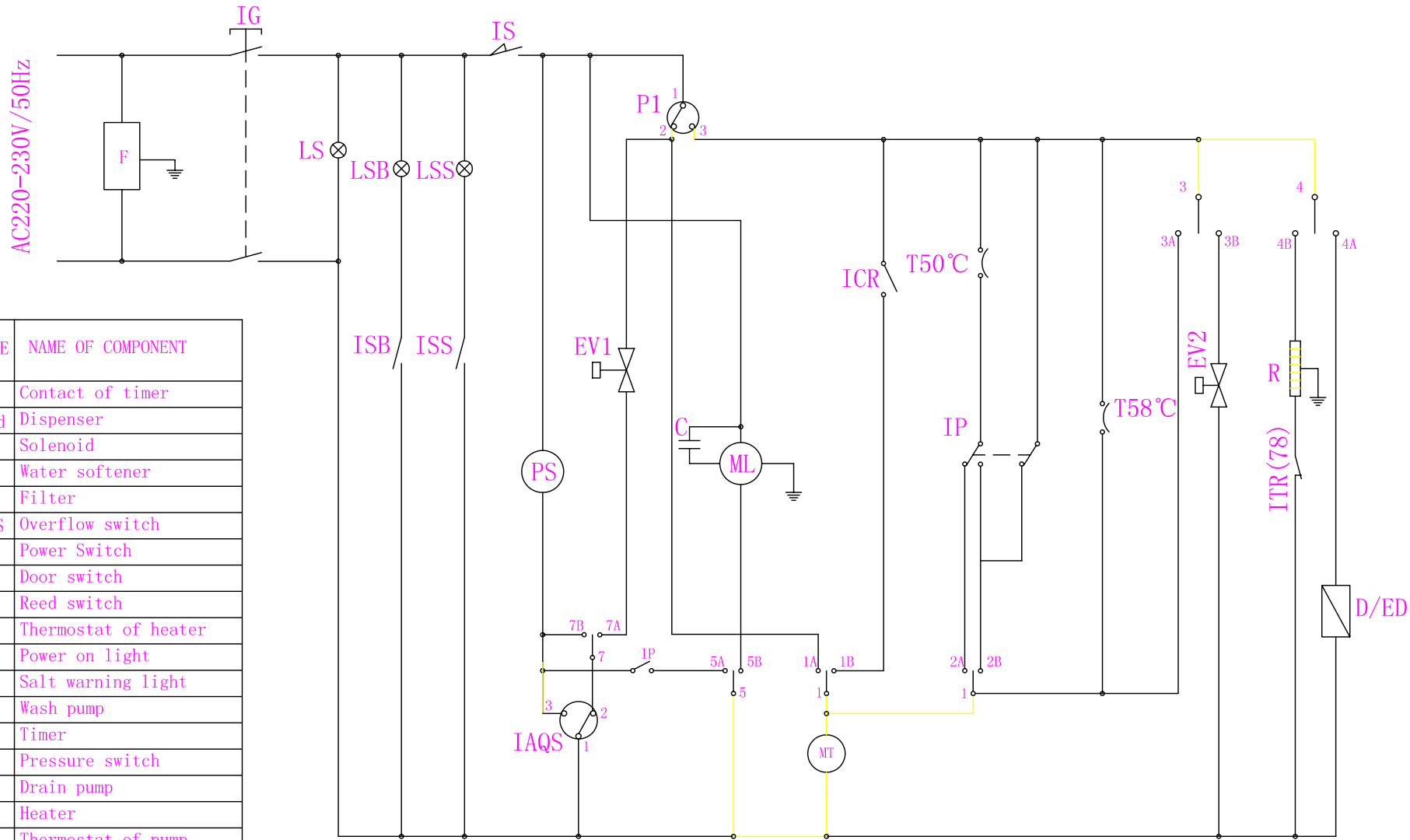

SPECIFICATION:

1. Model of timer: TD010088.00;
2. Rated voltage: 220-230VAC/50Hz;
3. Rated power: 1760-1930W;

Circuit
Diagram

